

# Industrial Data Communications Product Guide

 **westermo**<sup>®</sup>





## **Westermo World Wide . . . [www.westermo.com](http://www.westermo.com)**

Westermo was established in the early 70s. The headquarters are located 150 km southwest of Stockholm in Sweden. During these three decades the Westermo Company has grown with subsidiaries in Sweden, England, Germany, Norway, France and partners in over 30 Countries around the world.

Today the Westermo brand name is synonymous with Industrial Data Communications. Our 30 years of experience in the industrial market goes far beyond our own products. We know the problems that can occur in applications installed in harsh industrial environments and therefore we can offer you effective and economical solutions.

All our products are specifically designed to operate reliably in harsh industrial environments and in applications requiring high levels of reliability and availability.

Let Westermo be your natural choice for reliable data communication solutions.



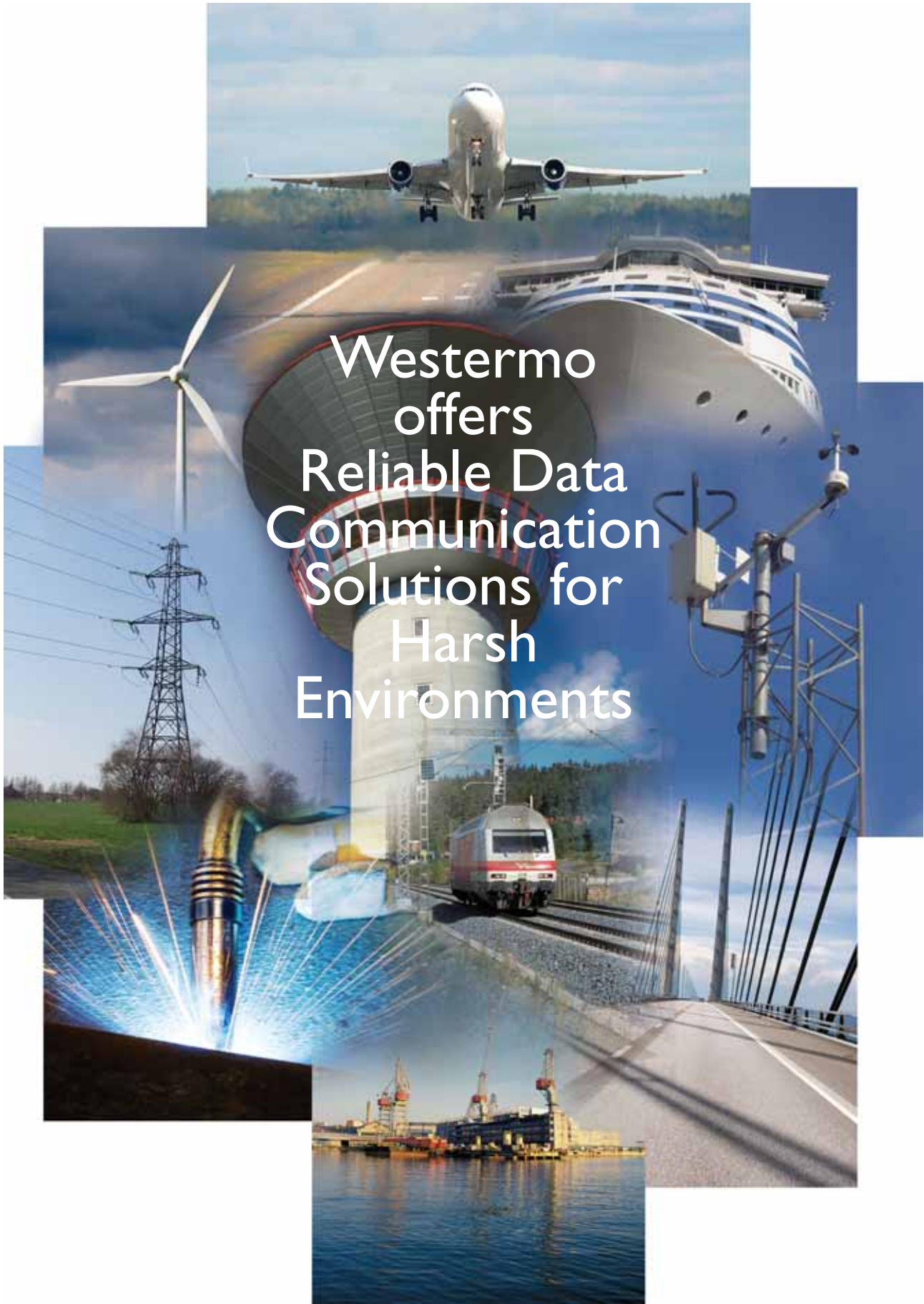

Westermo  
offers  
Reliable Data  
Communication  
Solutions for  
Harsh  
Environments

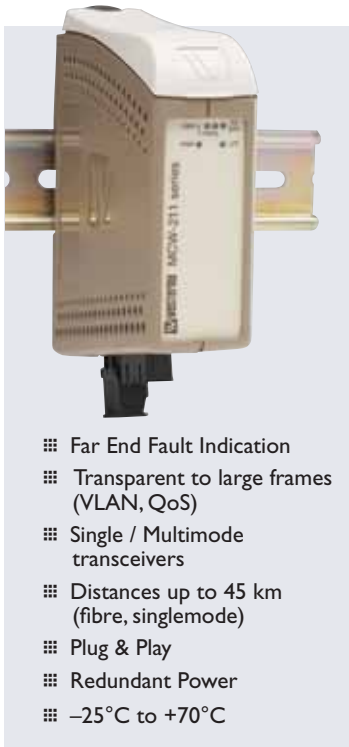

## MCW-211 Media Converter

The MCW-211 is an Industrial Ethernet FX/TX Media Converter. The MCW-211 converts data between Ethernet 10/100 Base-TX and 100 Base-FX. The unit is easy to install and use due to features like speed auto-negotiation, duplex auto-crossover and auto-polarity.

The media converter is transparent for large frames (VLAN or QoS). It is also possible to set speed, duplex and flow control via DIP-switches.

The FX side supports Far-End-Fault indication.

A link fault from either side will be forwarded to the other side – Link Fault Forwarding.

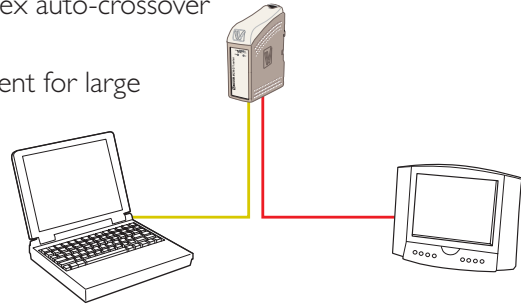

- ⌘ Far End Fault Indication
- ⌘ Transparent to large frames (VLAN, QoS)
- ⌘ Single / Multimode transceivers
- ⌘ Distances up to 45 km (fibre, singlemode)
- ⌘ Plug & Play
- ⌘ Redundant Power
- ⌘ -25°C to +70°C



## SDW-500 Unmanaged Ethernet Switch

The SDW is a 5 port switch which can be configured with one or two fibre optic transceivers for both multi and Singlemode. The switch is a plug & play unit but each port can be configured by DIP-switches as well. The screen of each TX port is individually isolated to help prevent earth loop problems within the network.

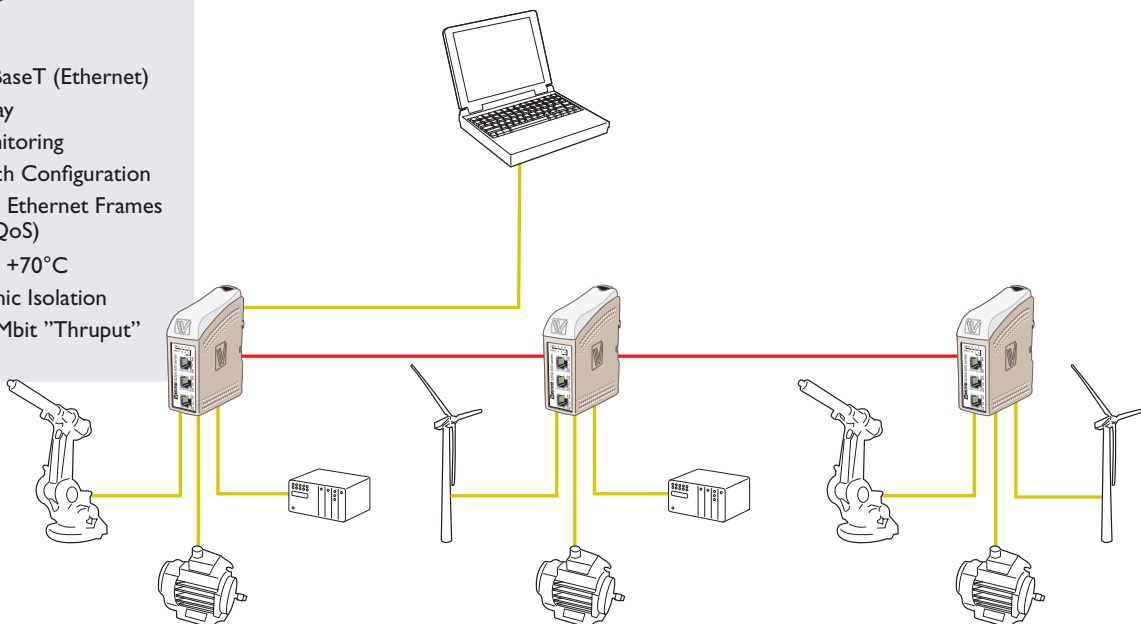

- ⌘ 10 / 100BaseT (Ethernet)
- ⌘ Plug & Play
- ⌘ Port Monitoring
- ⌘ DIP-switch Configuration
- ⌘ Extended Ethernet Frames (VLAN, QoS)
- ⌘ -25°C to +70°C
- ⌘ Tri-Galvanic Isolation
- ⌘ Full 100 Mbit "Thruput"

## EDW-100 / 120 Serial Ethernet Adapter

The EDWs allow devices with only a serial port to communicate over an Ethernet network. They can be used either in point-to-point or point-to-multi-point applications.

The EDW-100/120 are supplied with a software utility allowing virtual COM ports to be created on a PC. This software will redirect data, originally sent to a local COM port, to the remote serial interface of the EDW-100/120 meaning no changes are required to legacy applications. This makes it possible for "old" serial devices to communicate on a standard Ethernet network thus removing the need to maintain two different networks.

The EDW-100 has one serial port and EDW-120 has two.

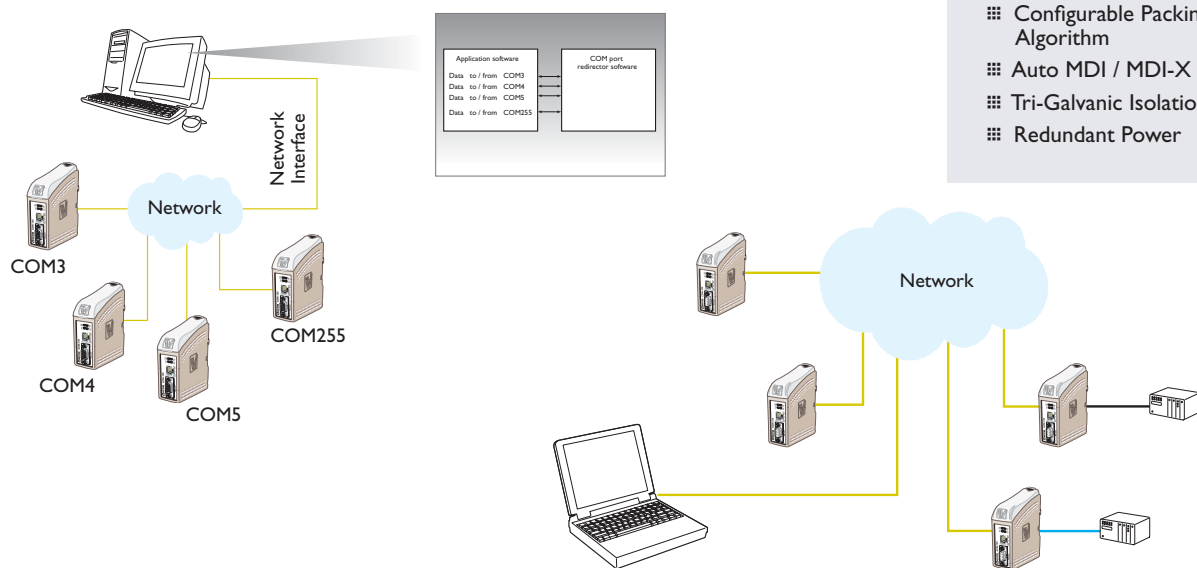

- ⌘ RS-232 / 422 / 485
- ⌘ 115.2 kbit/s (serial)
- ⌘ 10 / 100BaseT (Ethernet)
- ⌘ Configurable Packing Algorithm
- ⌘ Auto MDI / MDI-X
- ⌘ Tri-Galvanic Isolation
- ⌘ Redundant Power

## DDW-100 Ethernet SHDSL Extender

The DDW-100 is a plug and play Industrial Ethernet SHDSL extender. It is designed as a transparent extender for 10/100BaseTX networks. SHDSL represents the best of several symmetric DSL technologies. This unit provides the possibility to re-use existing twisted copper pair with a high data rate at long distances.

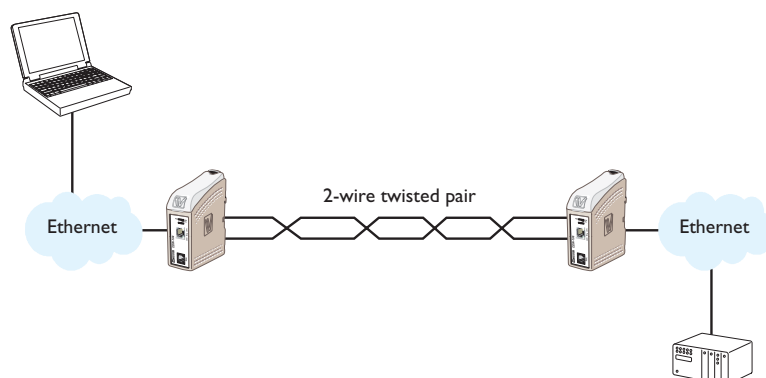

- ⌘ 10 / 100BaseT (Ethernet)
- ⌘ SHDSL Twisted Pair
- ⌘ Distances up to 10 km (6.2 mi)
- ⌘ 192 kbit/s up to 2.3 Mbit/s
- ⌘ Auto Speed Detection
- ⌘ -25°C to +70°C
- ⌘ Tri-Galvanic Isolation
- ⌘ Redundant Power



- ⌘ 10 / 100 / 1000 Mbit/s
- ⌘ Distances on fibre up to 120 km
- ⌘ Multi- or Singlemode transceivers
- ⌘ BIDI transceiver (send / receive on one fibre)
- ⌘ 2 configurable fibre ports
- ⌘ IP 40 / Metal Housing
- ⌘ Temperature range -40°C up to +70°C
- ⌘ Redundant Power (19 – 60V DC)
- ⌘ User configurable Fault Contact
- ⌘ All switches in the network configurable from any port on any switch with IP Config Tool
- ⌘ Web tool for configuration

## The Lynx Series – One switch many Solutions

Lynx is a range of switches consisting of three different function levels and four different type approvals (Industrial, Marine, Railway and Substation), giving you the ability to select the perfect switch for your application providing optimum functionality at the best value.

### Lynx 100 / 1100

- ⌘ SNMP (read only)
- ⌘ Real Time Ethernet
  - QoS / IPToS
  - 4 priority queues
  - Strict priority
  - HoL blocking prevention

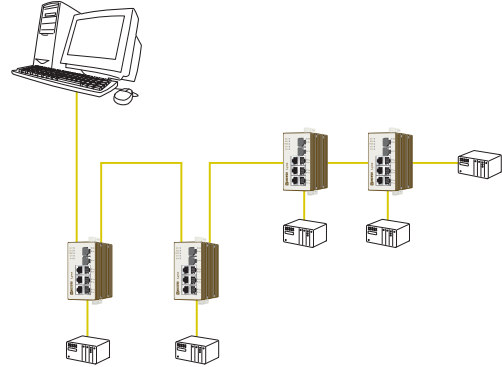

### Lynx 300 / 1300

- ⌘ FRNT v.0 (ring)
- ⌘ STP / RSTP
- ⌘ SNMP / Traps
- ⌘ Real Time Ethernet
- ⌘ 20 ms link recovery

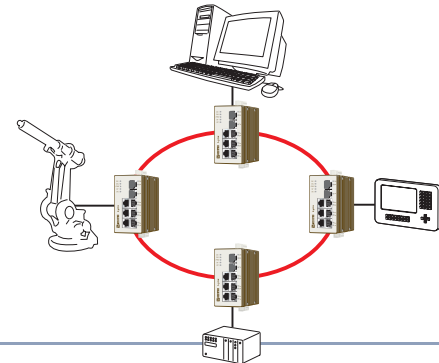

### Lynx 400 / 1400

- ⌘ VLAN
- ⌘ IGMP Snooping
- ⌘ FRNT v.0 (ring)
- ⌘ STP / RSTP
- ⌘ SNMP / Traps
- ⌘ Real Time Ethernet
- ⌘ 20 ms link recovery

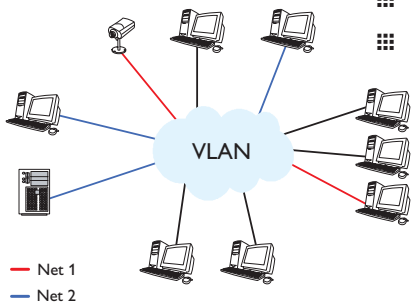
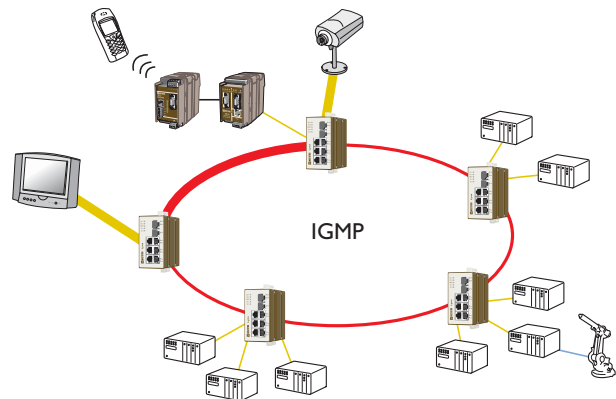

## Fastest Switch on the Market

Our unique FRNT technology (**F**ast **R**ecovery of **N**etwork **T**opology) is the fastest existing protocol on the market to reconfigure a redundant network in case of any failure on the fibre optic link.

FRNT is able to reconfigure a redundant ring network consisting of up to 200 switches within 20 ms, regardless of network load.

## R208 8 port Managed Switch

The R208 switch has the same features as the L400. R208 also has "Bridge Link" functionality (FRNT v.1) to provide full redundancy in networks where sub-rings need to be connected resiliently.

The R208 can be configured with up to 8 fibre ports.

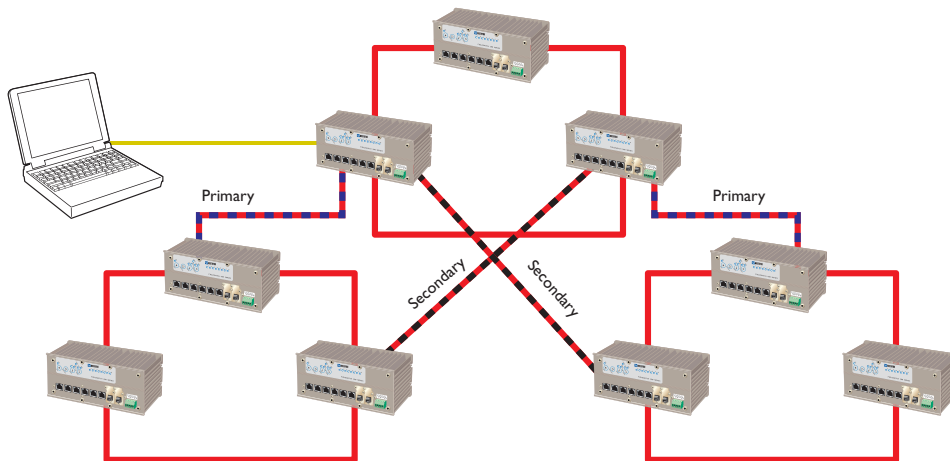

- ⌘ 8 configurable FX ports
- ⌘ Distances on fibre up to 120 km
- ⌘ Multi or Singlemode transceivers
- ⌘ BIDI transceiver (one fibre send / receive)
- ⌘ IP 40 / Metal Housing
- ⌘ Temperature range -40°C up to +70°C
- ⌘ Redundant Power (19 – 60VDC)
- ⌘ User configurable Fault Contact
- ⌘ All switches in the network configurable from any port on any switch with IP Config Tool

## T208 8 port Synchronized Time Server

The embedded time server provides precise time stamping. When used with packet prioritization, an accuracy of 1  $\mu$ s is possible. It is possible to use the internal clock or connect a GPS receiver to obtain an absolute time reference.

The T208 also has all the features of the R208.

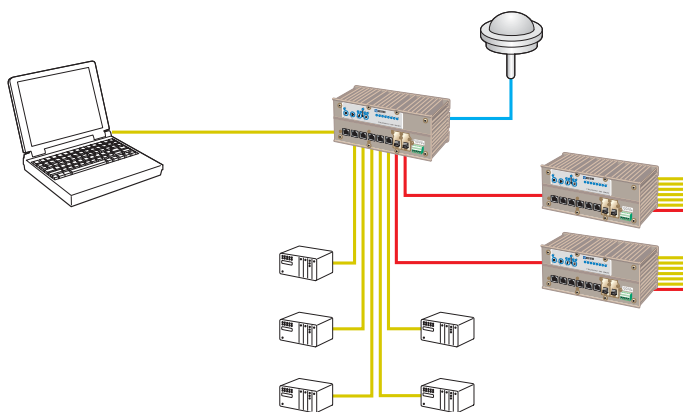

- ⌘ GPS or Internal Clock
- ⌘ GPS receiver interface RS-232 / 485
- ⌘ NTP / SNTP (Network Time Protocol)
- ⌘ RFC2030 / T1588 Compliant
- ⌘ Accuracy better than 1  $\mu$ s
- ⌘ IRIG-B
- ⌘ PPS (pulse per second)

## RM-80 / 90 / 240

- ⌘ RM-80, 869 MHz (Europe), 76 kbit/s
- ⌘ RM-90, 900 MHz (US), 200 kbit/s
- ⌘ RM-240, 2.4 GHz, 802.11b, 11 Mbit/s
- ⌘ Ethernet: 10/100baseT
- ⌘ Serial: 115.2 kbit/s
- ⌘ -35°C to +65°C
- ⌘ AES / WEP encryption
- ⌘ Firewall protection
- ⌘ Access Point / Client / Repeater
- ⌘ Bridge / Router



## GDW-11

- ⌘ 900 / 1800 MHz
- ⌘ 850 / 1900 MHz (GD-01)
- ⌘ CSD: 14.4 kbit/s
- ⌘ GPRS: 85.6 kbit/s
- ⌘ Serial: 115.2 kbit/s
- ⌘ -25°C to +50°C
- ⌘ SMS via DTR
- ⌘ Dial-up via DTR



## IDW-90

- ⌘ RS-232 / 422 / 485
- ⌘ Serial: up to 230 kbit/s
- ⌘ ISDN: up to 124 kbit/s
- ⌘ PSTN: up to 33.6 kbit/s
- ⌘ Tri-galvanic isolation
- ⌘ SMS / Dial-up via I/O / DTR



## Wireless Solutions

If the cost of wiring means that you cannot justify a project, then a wireless connection could be the solution for the project to be approved. It could be long distances where cabling is not even considered, or when there is an obstacle to wiring – public roads, railway lines, tarmac, waterways etc. It is also a solution for movable or moving equipment as well as temporary installations.

Using GSM/ GPRS gives you the possibility to connect to any serial device worldwide. One condition is, however, that it is within the coverage area of a GSM operator.

## WLAN Access point and Client

The modems provide reliable and secure wireless connection between devices with Ethernet or serial RS-232 / RS-485 interfaces. A line of sight distance of 1 km (0.62 mi) is possible with the RM-240 and up to 5 km (3.1 mi) with the RM-80.

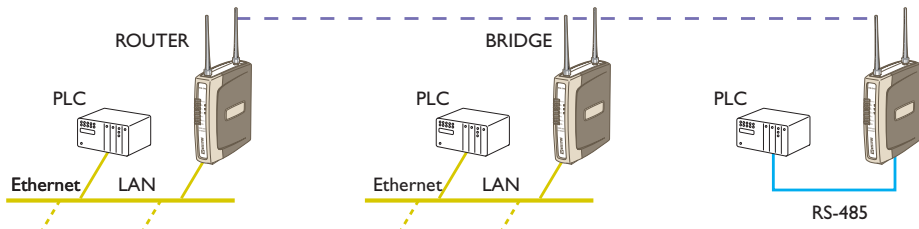

## GSM / GPRS

The GSM modems provide possibilities to control or monitor equipment with a serial interface from a remote location. The DTR signal could be used to trigger an SMS message or a dial-up connection to a pre-programmed number.



## ISDN-adapter

The advantage with ISDN is the data rate as well as the fast connection time, less than 1 second compared with 15 to 25 seconds with an analogue modem. The IDW-90 also has a built-in analogue V.34 modem, which eliminates the need for separate modems for analogue and digital data transfers. This makes it ideal for system suppliers that have installations of both types.

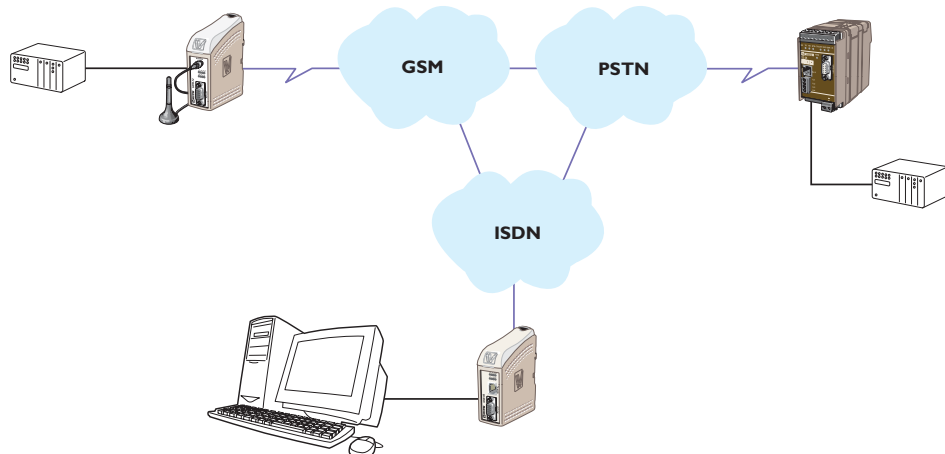

## Remote connection via telephone lines

The ability to create remote connections to equipment can provide great savings both in time and money. Not only this, but improved customer service can also be offered. It is possible to control, monitor, update software or fault find, irrespective of where the equipment is located, by means of a simple remote connection.

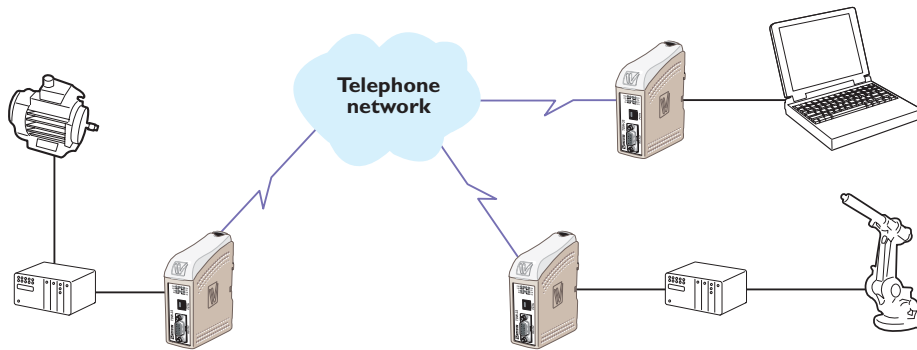

## Dial-up or Leased Line Communications

The TDW-33 is used for dial-up application only, but the TD-36 and TD-36/485 also have the ability to be used on leased lines of up to 25 km (15.5 mi).

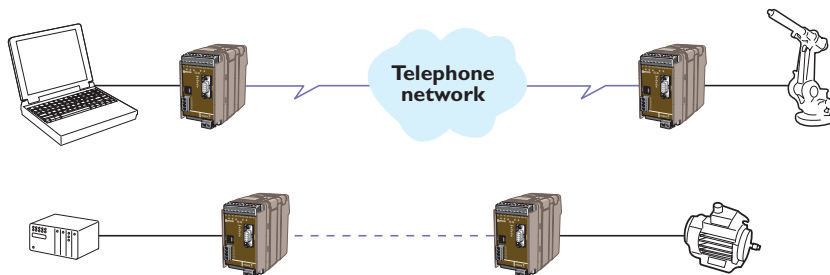

## Dial back-up on lease line failure

In case of a link failure on the leased line the TD-36/45 modem has the ability to automatically establish a new connection via the normal dial-up telephone line. This is a temporary connection between the devices until the leased line is re-established again.

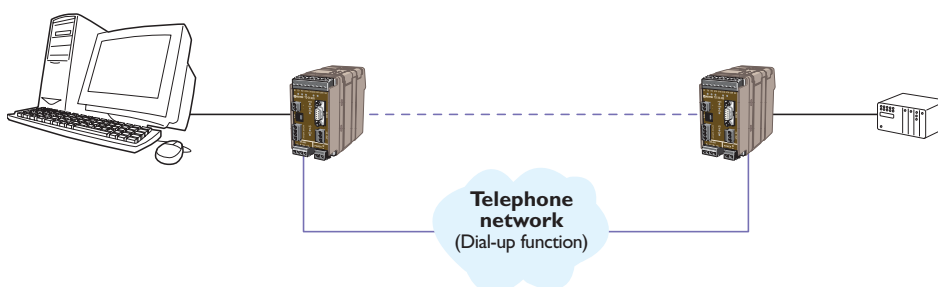

## Remote controlled I/O

TD-36 / 485 has a relay output that can be controlled by AT-commands or from the remote connected TD-36 / 485. This feature can be used for example to switch on/off some kind of device.



### General

- ⌘ RS-232, 115 kbit/s
- ⌘ -25°C to +70°C
- ⌘ 11 bit data format
- ⌘ Password / Dial-back
- ⌘ Tri-galvanic isolation
- ⌘ DTR dial-up
- ⌘ Watchdog
- ⌘ Remote Configuration
- ⌘ TD-Tool (configuration)



### TDW-33

- ⌘ Line: 56 kbit/s (V.90)



### TD-36

- ⌘ Line: 33.6 kbit/s with Fast Connect
- ⌘ 2-wire Leased Line
- ⌘ DIP-switch configuration
- ⌘ V23 HDX with multidrop



### TD-36 / 485

- ⌘ Line: 33.6 kbit/s with Fast Connect
- ⌘ 2- / 4-wire Leased Line
- ⌘ V23 FDX/HDX with multidrop
- ⌘ RS-485
- ⌘ Dial-up in case of link failure on Leased Line

## General

- ⌘ Router with integrated switch
- ⌘ Brouter with Firewall
- ⌘ PPP
- ⌘ SNMP
- ⌘ Web tool



## ED-210

- ⌘ Integrated V.34 modem
- ⌘ Leased Line
- ⌘ Dial in /Dial out
- ⌘ Call back security

## ED-200

- ⌘ RS-232 or RS-422
- ⌘ Modem initialisation

## DR-200

- ⌘ Data rate up to 2 Mbit/s
- ⌘ 4 x 10 / 100BaseT
- ⌘ 1 x RS-232 up to 400 kbit/s
- ⌘ Asynchronous / Synchronous
- ⌘ Security: Firewall / Encryption
- ⌘ -20°C to +55°C
- ⌘ Power: 24VDC



## MR-200

- ⌘ 850, 1800, 1900 MHz
- ⌘ GPRS Class 10
- ⌘ 2 SIM card holders
- ⌘ 1 x 10 / 100BaseT
- ⌘ 1 x RS-232 up to 400 kbit/s
- ⌘ Asynchronous / Synchronous
- ⌘ Security: Firewall / Encryption
- ⌘ -20°C to +55°C
- ⌘ Power: 12 – 24VDC



## Remote connection to Ethernet Networks

A router is a device, or in some cases software in a computer, that determines where a packet should be sent on its way to the end destination (the router is the end destination from a LAN's perspective).

Subsequently, the router is a network device that links together two or more logically separate networks. It does not connect networks blindly, but acts more as a packet switch and as a filter for the interconnection of local networks over short or long distances.

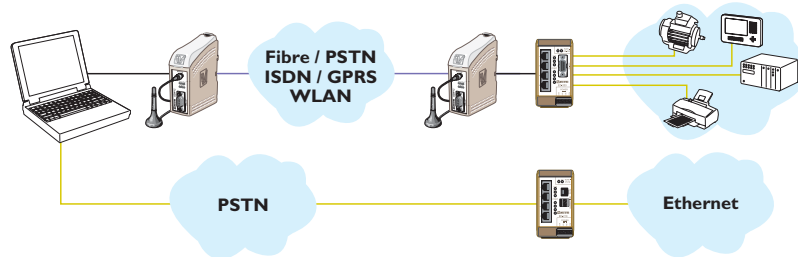

## Serial and PSTN Router

The ED-200 has a serial port that can be connected to any communication product, which offers a wide range of possibilities like ISDN, GSM / GPRS, WLAN etc.

## ADSL Router

The ADSL technique offers high speed access to remote sites over an existing analogue telephone connection, at speeds of up to 2 Mbit/s.

The DR-200 has features such as firewall, encryption of data and VPN tunneling to secure data transmission between two sites. Equipment with a serial RS-232 or four 10 / 100BaseT ports can be connected to the DR-200. The DR-200 supports routing protocol such as: VRRP, OSPF and RIP2.

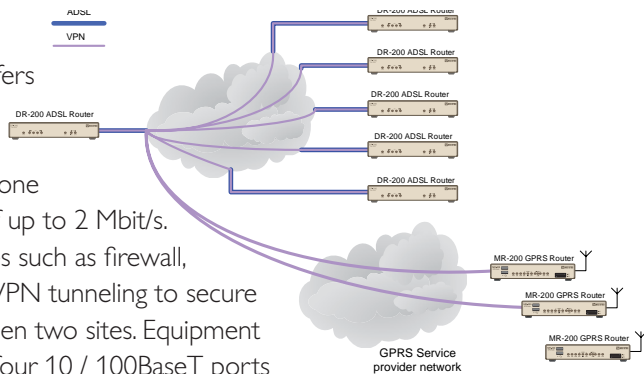

## GPRS Router

MR-200 offers a wireless connection using the GSM / GPRS network. The MR-200 has features such as: firewall, encryption of data and VPN tunneling to secure data transmission between two sites.

Equipment with a serial RS-232 or a 10 / 100BaseT port can be connected to the MR-200.

The MR-200 supports routing protocol such as: VRRP, OSPF and RIP2.

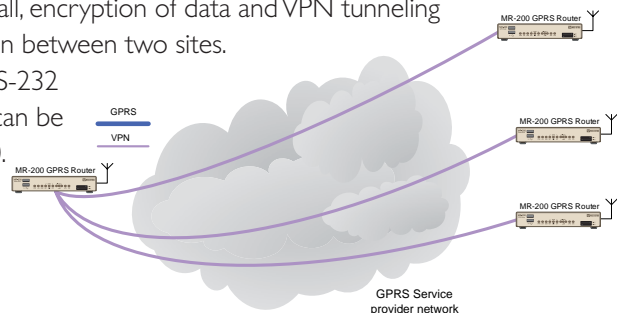

## Multidrop connections via copper cable

This product range allows multidrop networks to be created using either dedicated cables or leased lines. The number of drop points and distances vary depending on which product/transmission technique is used.

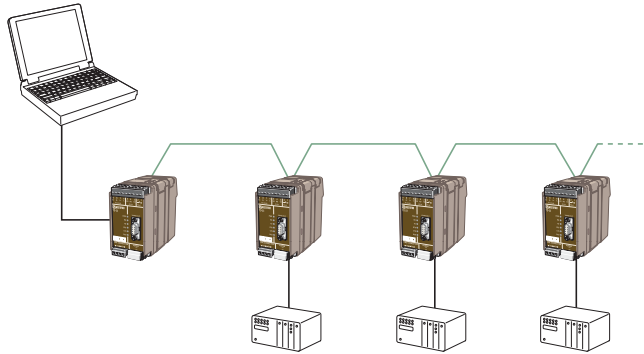

## Multidrop via leased lines

The TD-23 can communicate via a 2- or 4-wire leased line according to the V.23 standard.

The modem has DIP-switches allowing specific functions to be set, for example, reception sensitivity, output signal level, etc. This is of particular importance as it allows each modem to be optimized according to the line quality.

A general calculation allows 16 units over a distance of up to 25 km (15.5 miles).

## Multidrop via dedicated lines

TD-29 is intended for half duplex communications via a 2-wire dedicated line. The transmission distance and number of multidrop points are affected by the number of connected modems and line quality. A typical value is 10 units up to 10 km (6.2 miles) at a transfer rate of 9600 bit/s. TD-29 is intended for use on dedicated lines and must not be connected to general or leased telecom lines. The TD-29P is designed to be used with PROFIBUS DP protocol.

Westermo's  $\pm 10$  mA balanced current loop (W1) transmission technique makes it possible to transmit data up to 18 km (11.2 mi) at low data rates on a 4-wire cable. At shorter ranges transmission rates up to 38.4 kbit/s can be achieved. The LD-01 / 02 is also available in a "by-pass" version. This model ensures that if a modem in the multidrop network should fail that modem will be by-passed, hence not effecting the communications between other units on the network.

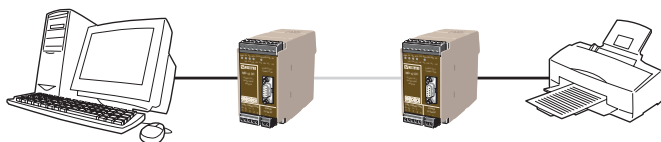

## Point-to-point on dedicated copper wire

The MD-12 is used in point-to-point applications or as a start and end modem in a multidrop installation with products using W1 technology. 4-wire is needed to achieve a half or full duplex communication. The W1 technology makes it suitable to use in harsh environments.



### TD-23

- ⌘ 1 200 bit/s (V.23)
- ⌘ RS-232 / 422 / 485
- ⌘ Tri-galvanic isolation
- ⌘ Transient protection



### TD-29 / TD-29P

- ⌘ Up to 19.2 kbit/s
- ⌘ RS-232 / 422 / 485
- ⌘ Watchdog
- ⌘ Tri-galvanic isolation
- ⌘ Transient protection



### LD-0x (Multidrop)

- ⌘ RS-232 (LD-01)
- ⌘ RS-422 / 485 (LD-02)
- ⌘ By-Pass function (LD-01)
- ⌘ Tri-galvanic isolation
- ⌘ Protocol independent
- ⌘ Up to 38.4 kbit/s

### MD-12

- ⌘ RS-232
- ⌘ 4-wire (half / full duplex)
- ⌘ Up to 38.4 kbit/s
- ⌘ Up to 18 km (11.2 mi)
- ⌘ Tri-galvanic isolation
- ⌘ Protocol independent



### LR-01 / LR-01PP

- ⌘ 78 kbit/s TP/FT-10
- ⌘ ST-connectors
- ⌘ Regenerated optical signal
- ⌘ Transparent
- ⌘ AC or DC supply



### LR-11 / LR-11PP

- ⌘ 78 kbit/s TP/FT-10 or 1.25 Mbit/s
- ⌘ Router function (RTR-10)
- ⌘ ST-connectors
- ⌘ Regenerated optical signal
- ⌘ AC or DC supply



### AD-01

- ⌘ 2 x RS-232 (M-Bus)
- ⌘ 1 x M-Bus Master
- ⌘ 1 x M-Bus Slave
- ⌘ Data rates up to 9.6 kbit/s
- ⌘ Autobaud function
- ⌘ Up to 120 M-Bus slaves
- ⌘ Act as a:
  - Converter
  - Repeater
  - Zone controller

## Fibre optic solutions for LONWORKS® networks

These units are used to extend the transmission range between two or more LONWORKS® networks on a single- or multimode fibre optic cable up to distances of 25 km (15.5 mi). It can either be a point-to-point, multidrop or a redundant ring solution. For point-to-point applications the PP-version is used. The modems have an alarm output to indicate if any failure occurs on the fibre optic link.

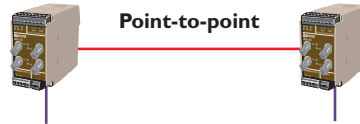

## Fibre Optic Repeater

The LR-01 is totally transparent, which gives the advantage that no software configuration via an installation tool is necessary, its just "plug & play". Because of the transparency the number of units in a multidrop or redundant ring installation is limited to ten.

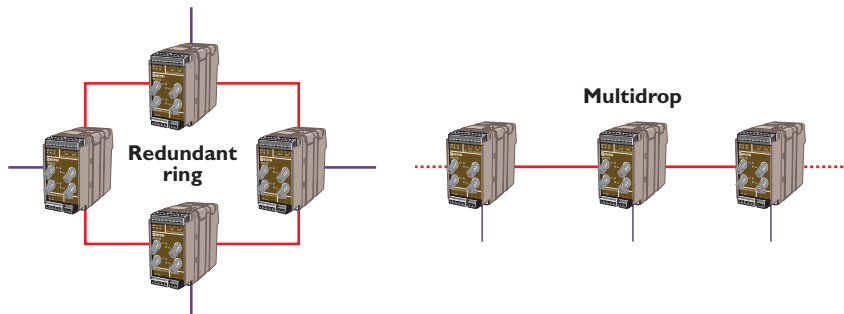

## Fibre Optic Router

The LR-11 is based on Echelon's router module RTR-10, which makes configuration / installation possible using the LonBuilder® or LonMaker™ installation tools. The LR-11 can be installed as repeater, configured router or learning router. The Lon-interface can be 78 kbit/s or 1.25 Mbit/s depending on model.

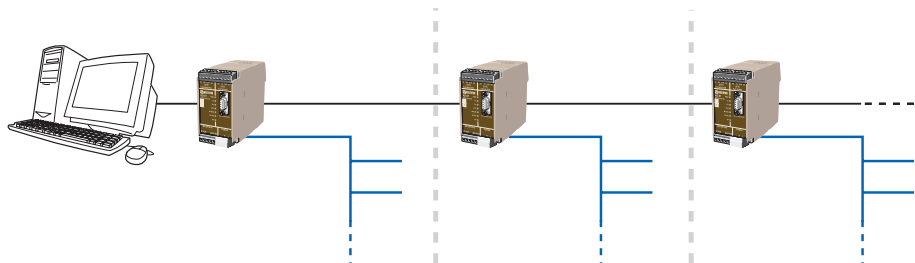

## Solutions for M-Bus applications

The AD-01 has several functions, which make it easy to build a complete network. The adapter can be used as a converter from RS-232 to M-bus, a repeater to make the communication distance longer or to extend the distance between two M-bus networks using any kind of serial RS-232 communications equipment.

## Fibre Optic

Fibre Optic cable has the advantages that it is completely insensitive to electrical and magnetic disturbances. It is therefore ideal to install as a communication media in harsh industrial environments.

It also provides benefits such as high data rates over long distances.

Depending on choice of transceiver and cable (multimode / singlemode) distances up to 80 km (49.7 mi) can be achieved.



## Point-to-Point

The modems can be used in point-to-point communications between two devices with serial interfaces. If two modems with different serial interfaces are used then a conversion from RS-232 to RS-422/485 can also be made over the fibre optic cable.

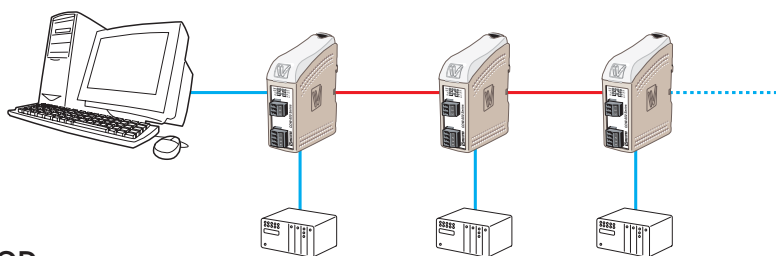

## Multidrop

The modems can be used in multidrop applications where the connected devices have a serial interface. Depending on transceiver and cable distances up to 80 km (49.7 mi) can be achieved between each modem and with unlimited drop points (protocol dependant).

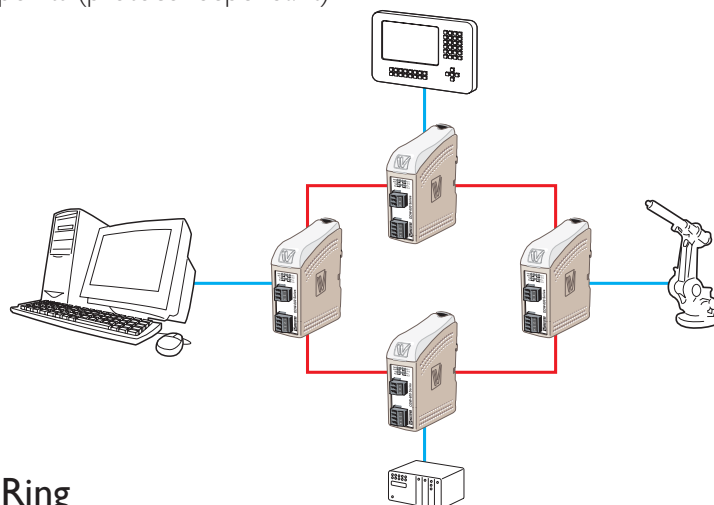

## Redundant Ring

The best product choice for applications where total reliability and resilience is required is our redundant ring modems. If there is a link failure between two modems the units will automatically switch the data direction and establish a communication path in the other direction.

### General

- ⌘ Multi- / Singlemode
- ⌘ Distances up to 80 km (49.7 mi)
- ⌘ Link Fault Relay
- ⌘ Redundant Power
- ⌘ 10 – 60 VDC, 20 – 30 VAC
- ⌘ Galvanic isolation
- ⌘ -40°C to +55°C
- ⌘ IP21
- ⌘ DIP-switch configuration



### ODW-61x

- ⌘ PROFIBUS DP
- ⌘ Up to 12 Mbit/s
- ⌘ Autobaud



### ODW-62x

- ⌘ RS-232
- ⌘ Up to 250 kbit/s



### ODW-63x

- ⌘ RS-422/485
- ⌘ Up to 1.5 Mbit/s



### FD-10 (slave)

- ⌘ Up to 12 Mbit/s
- ⌘ Serial RS-232 / 485 with data rates 1.2 to 38.4 kbit/s
- ⌘ Transparent transmission of up to 65 DP I/O-words
- ⌘ Tri-galvanic isolation



### FD-20 (Master)

- ⌘ Up to 12 Mbit/s
- ⌘ RS-232 / 485 with data rates 1.2 to 38.4 kbit/s
- ⌘ Acts as the master and controls all PROFIBUS DP-traffic with connected slaves.
- ⌘ Tri-galvanic isolation



### FD-40

- ⌘ Up to 12 Mbit/s
- ⌘ RS-232 / 485 with data rates 1.2 to 38.4 kbit/s
- ⌘ 15 kbyte In/Out buffer
- ⌘ 15 kbyte transmit buffer
- ⌘ Tri-galvanic isolation

## Solutions for PROFIBUS DP application

There are some limitations when using PROFIBUS DP because of its use of the RS-485 electrical interface. One limitation is the transmission range, which is limited to 200 m at 12 Mbit/s. The following products provide solutions where pre-existing cables / networks (Ethernet) or even a wireless solution can be used to link PROFIBUS DP networks. The FD-40 also allows an unintelligent serial device to be connected to a PROFIBUS DP network.



## Serial link between PROFIBUS DP networks

The FD-10 and FD-20 are used to establish a serial link and transfer I/O data between two or more PROFIBUS DP networks. It could be on an existing Ethernet network, dial-up, fibre optic link or even a wireless connection via radio or GSM.

The FD-10 is used when there is a master in each PROFIBUS DP network. The FD-20 can be used as a master in a PROFIBUS DP network.

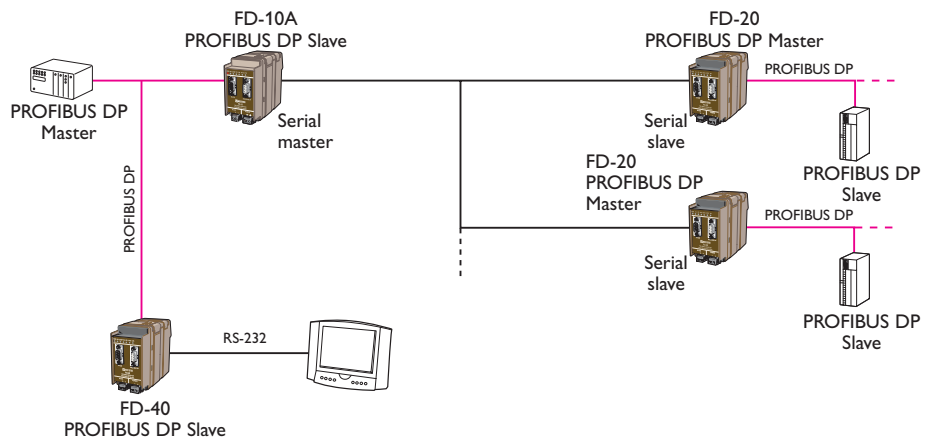

## Connect a serial device to a PROFIBUS DP network

The FD-40 Fieldbus converter allows devices with serial RS-232 or RS-485 interfaces to be integrated into PROFIBUS DP networks. The FD-40 works as a PROFIBUS DP slave module enabling serial data to be transmitted as normal DP process data.

## Interface Converters

The MDW-45 is a serial RS-232 to RS-422 / 485 interface converter. The unit can also be used in point-to-point and multidrop applications on 2 or 4-wires with data rates up to 100 kbit/s and cable lengths up to 1200 metres. The MD-21 is a converter between serial RS-232 and 20 mA current loop.

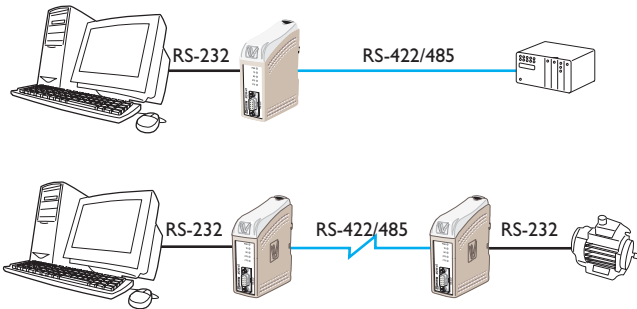

## Serial Repeaters / Isolators

These units are used to extend distances or to provide galvanic isolation between different equipment in installations where ground potentials may cause problems. The MD-52 is used together with RS-232 equipment and the RD-48 with RS-422 / 485.

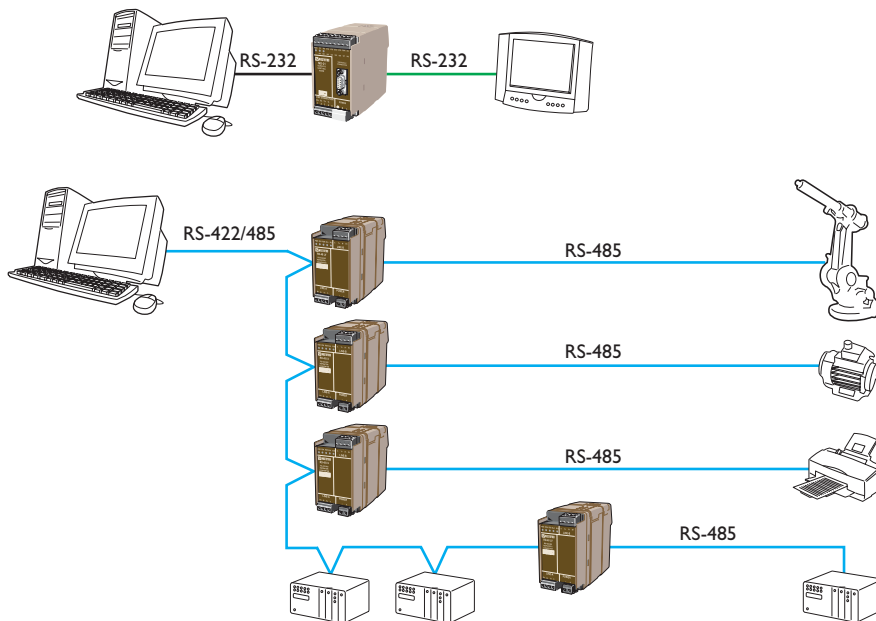

## RS-422 / 485 Repeater / Isolator

According to the standard the RS-422/485 interface is able to support a total of 32 connected devices and a transmission range of up to 1200 meters (4000 ft). A repeater can be used to extend the range by an extra 1200 metres or to add another 32 connected devices. Up to 8 repeaters can be used in a single network. The RD-48 can also allow star networks to be created, provide galvanic isolation between segments and correct termination of the line.



### MDW-45

- ⌘ Up to 100 kbit/s
- ⌘ Direction controlled by data flow or RTS
- ⌘ Termination and fail-safe selectable via switch
- ⌘ Tri-galvanic isolation
- ⌘ Protocol transparent
- ⌘ -40°C to +70°C



### MD-21

- ⌘ Up to 19.2 kbit/s
- ⌘ Distances up to 6 km (3.7 mi)
- ⌘ Tri-galvanic isolation
- ⌘ Transmitter / Receiver active or passive
- ⌘ Protocol transparent



### MD-52

- ⌘ Up to 115.2 kbit/s
- ⌘ 9-pos. D-sub, DTE
- ⌘ 9-pos. D-sub, DCE

### RD-48

- ⌘ Up to 1.5 Mbit/s
- ⌘ Termination and fail-safe selectable via switch
- ⌘ Retiming for high data rates
- ⌘ 2- / 4-wire conversion



## H E A D O F F I C E

### Sweden

Westermo Teleindustri AB  
SE-640 40 Stora Sundby, Sweden  
Phone: +46 (0)16 42 80 00  
Fax: +46 (0)16 42 80 01  
info@westermo.se  
www.westermo.com

## S U B S I D I A R I E S

### Sweden

Westermo Data Communications AB  
SE-640 40 Stora Sundby  
Phone: +46 (0)16 42 80 00  
Fax: +46 (0)16 42 80 01  
info@westermo.se

### United Kingdom

Westermo Data Communications Ltd  
Talisman Business Centre  
Duncan Road, Park Gate, Southampton. SO31 7GA  
Phone: +44(0)1489 580 585  
Fax: +44(0)1489 580 586  
sales@westermo.co.uk  
www.westermo.co.uk

### Germany

Westermo Data Communications GmbH  
Goethe Strasse 67  
DE-68753 Waghäusel, Germany  
Tel: +49(0)7254 95400-0  
Fax: +49(0)7254-95400-9  
info@westermo.de  
www.westermo.de

### France

Westermo Data Communications S.A.R.L.  
Bat. A, 9 Chemin de Chilly  
FR-91160 Champlan, France  
Tél : +33 1 69 10 21 00  
Fax : +33 1 69 10 21 01  
infos@westermo.fr  
www.westermo.fr

### Norway

Westermo OnTime AS  
Gladsvei 20 0489 Oslo, Norway  
Phone +47 220 903 03  
Fax +47 220 903 10  
E-mail: contact@ontimenet.com