

®

WESTERMO

# **Wolverine** *Revolutionary Concept for Industrial Networks*



# Westermo Worldwide...

**Produced by:**

Westermo Teleindustri AB

**Photo:**

Norsk Hydro, IStockphoto  
BildN, Västerås, Sweden

**Illustrations:**

Visual Information Sweden AB  
Eskilstuna, Sweden

**Printed by:**

Eskilstuna Offset AB  
Sweden 2008

*Specifications are subject to  
change without notice due to  
continuous product develop-  
ment and improvement.*

Westermo was established in the early 1970s. The head office being located 150 km (93.2 miles) southwest of Stockholm in Sweden. Over the past three decades Westermo has grown with subsidiaries being established in Sweden, England, Germany, France, Singapore and sales partners appointed in over 30 Countries worldwide.

Today the Westermo brand name is synonymous with Robust Industrial Data Communications.

Our 35 years of experience in the industrial marketplace goes far beyond our own products. We understand the problems that can occur in applications installed in the toughest industrial environments and therefore we can offer you the most effective and economical solutions.

All our products are specifically designed to operate reliably in harsh industrial environments and in applications requiring the highest levels of reliability and availability.

*Let Westermo be your first choice for robust industrial data communication solutions.*



# Extend your network far beyond the normal limits of Ethernet

The Wolverine series consists of five units with one thing in common – the ability to allow you to ignore the conventional Ethernet boundaries for copper cable. By design, a standard Ethernet network has a transmission limit of 100 metres (328 ft) over UTP copper cables, the Wolverine allows you to go much further and on many other kinds of cable.

The Wolverine series utilises SHDSL technology on twisted pair cables to establish a high-speed remote connection between two Ethernet Networks.

Instead of needing to install fibre or radio links, the SHDSL technology can provide a cost-effective solution by using existing cables. Data rates up to 5.7 Mbit/s and an operating distance of up to 15 kilometres (9.3 miles) at lower data rates can be achieved. Depending on which unit you choose, there are also features like a built-in four port switch to provide a complete network solution, redundant ring protocol with the worlds fastest recovery time (FRNT), serial to IP conversion allowing legacy serial devices on your Ethernet network and much more.

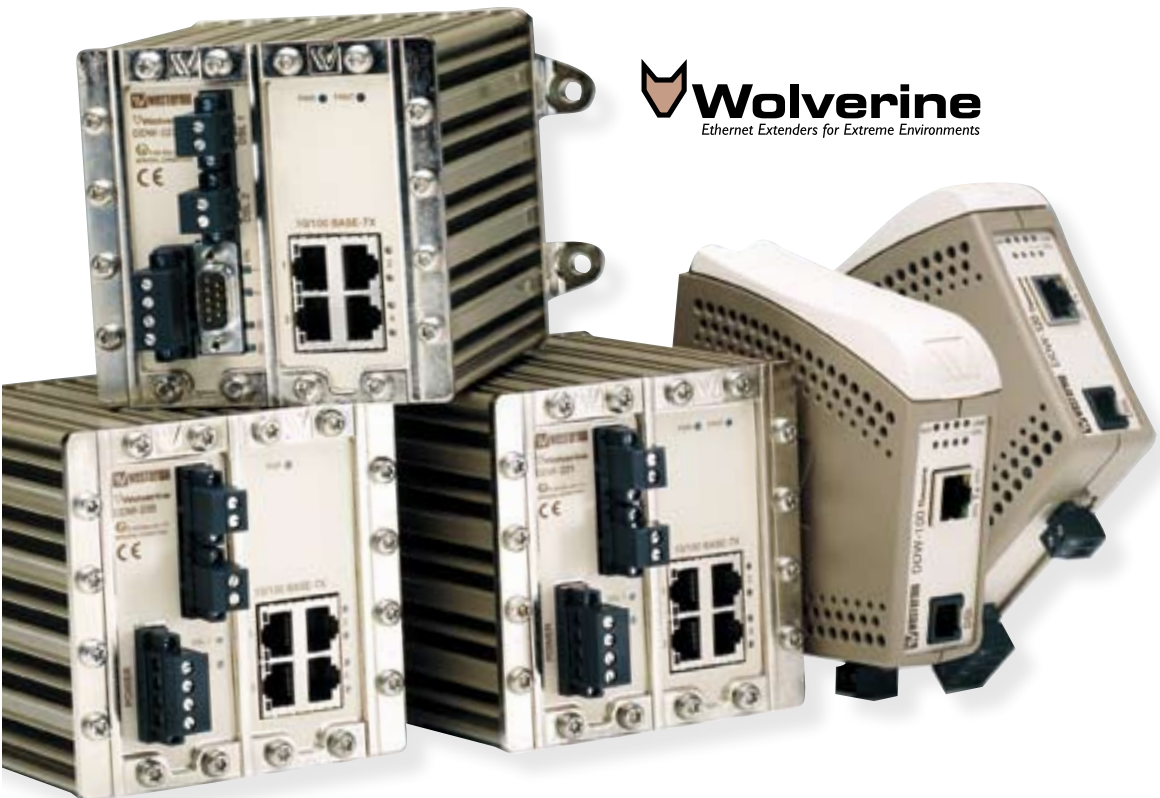

# Speed versus distance



The Wolverine extends your Ethernet network using SHDSL technology which means it can make use of previously installed cables, for example a local telephone network, old RS-485 network or pilot cables. At shorter ranges the data rate will be as high as 5.7 Mbit/s in both directions. The technology used suggests transmission distances of up to 10 km (6.2 miles) at lower data rates, depending on the quality of the cables. In practical applications however much greater distances have been achieved.

Speed and distance have been tested at an accredited test house using different cables and with and without simulated noise.

## Distances achieved in practical tests

The diagram below shows data rate versus distance for two different cable types, 0.4 mm<sup>2</sup> and 0.8 mm<sup>2</sup>, with different noise models. The type A noise model represents a high load scenario where the SHDSL cables are in a large cable bundle with hundreds of other wire pairs using other transmission technologies. The type B noise model represents a medium load scenario where the SHDSL pair is within a cable bundle with less than ten other wire pairs using other transmission technologies.

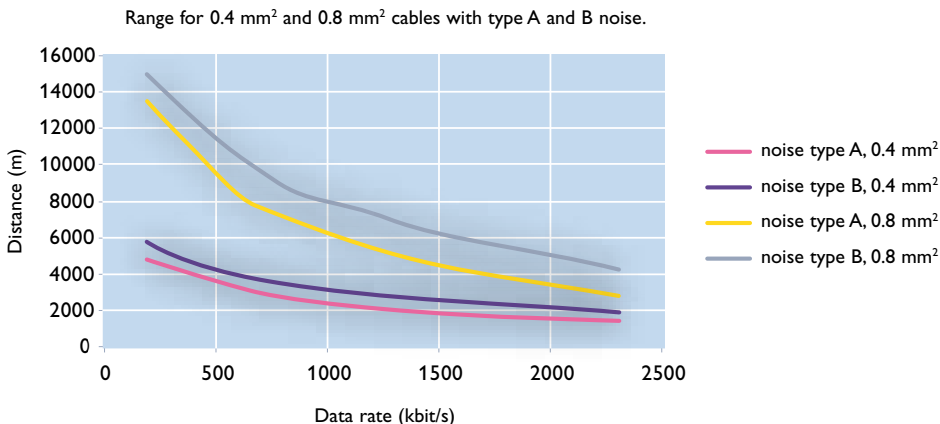

# Designed for harsh industrial environments

All five units in the Wolverine series are designed for use in harsh industrial applications and will operate in environments with high levels of electro-magnetic interference. The Wolverine series has gone through and passed extensive testing and approvals by both Westermo and accredited test houses. By using our own research and development department and our own manufacturing division, we can guarantee functionality and quality down to the most finite detail. Total galvanic isolation and transient protection are standard for all interfaces. The line interfaces are equipped with extensive protection in the form of a TBU (Transient Blocking Unit), which provides maximum protection against surges and transients. The units are built in a robust and rugged enclosures, which can be mounted, stand alone or on a DIN rail. The Wolverines can operate in extreme temperatures of between -40 to 70°C.

The units are supplied with redundant power inputs that can be powered from two separate sources, which allows for uninterrupted connectivity in case of a power failure on one supply. The power supply operates over a wide input range from 16 to 60VDC.

## Line interface and line protection

In demanding industrial applications reliability is a major factor. Equipment must be able to handle line disturbances and harsh environments.

The Wolverine units have been developed with increased protection on the DSL lines, this guarantees a high degree of reliability.

## DSL line interface

To prevent damage on the line interface a TBU (Transient Blocking Unit) is implemented on the DSL line. The TBU responds to both over-current and over-voltage faults on the line and can take care of indirect lightning, power induction and short circuit problems.

The TBU provides a high level of protection and also high speed functionality, which gives us excellent performance even with noise on the line.

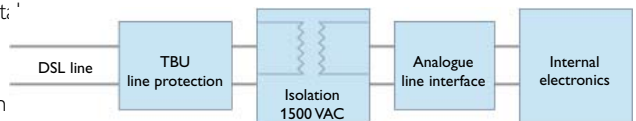

# Worlds fastest recovery time for redundant Ethernet



The DDW-221 and DDW-222 are equipped with a redundant ring feature for critical processes and harsh applications that require maximum operational readiness and system availability. The redundant protocol can be used either on the SHDSL interface or on the Ethernet interface.

The redundancy runs on our proprietary protocol, FRNT (Fast Recovery of Network Topology), which has the fastest recovery time in the world. This design delivers a redundant system that provides high availability, reliability, and safety.

## FRNT principles

FRNT is similar to the IEEE Spanning Tree Protocol (STP) in providing a redundant network solution. To provide rapid reconfiguration each unit in a FRNT ring has knowledge of the entire network topology as opposed to STP where only knowledge of neighboring switches is held.

A FRNT topology change event packet will be sent directly to the focal point in case of a topology change e.g. a link loss or a link establishment. The focal point will, based on the received change event packet generate a topology change command. This command is sent to every member of the ring.

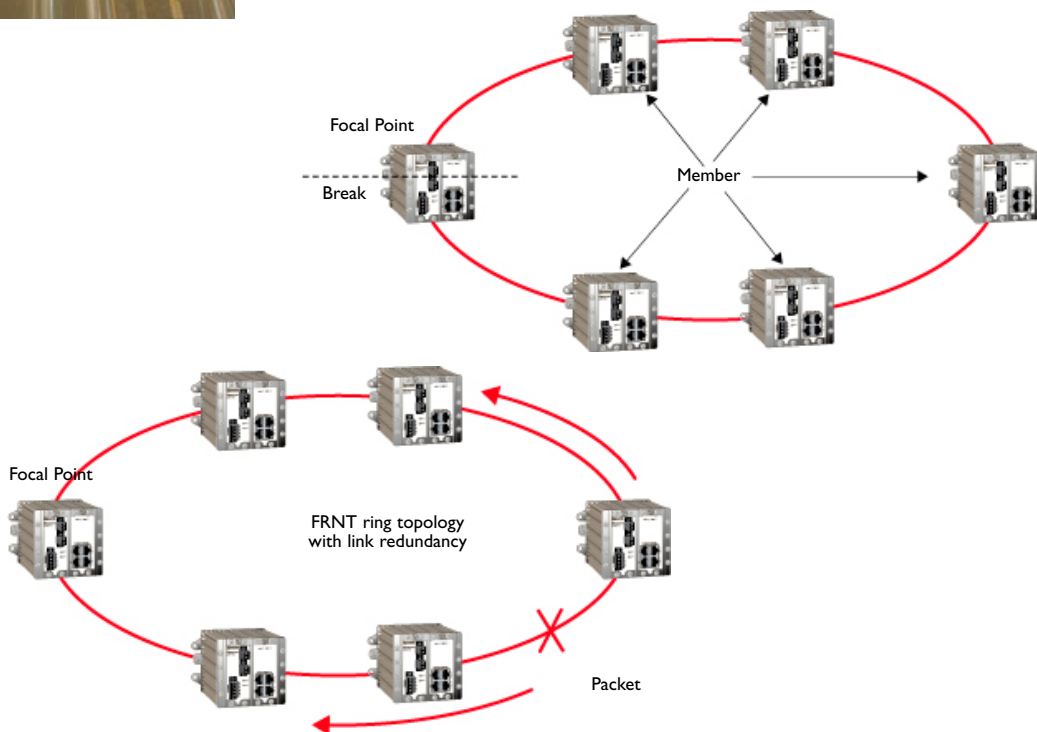

# Plug-and-play

For the DDW-22x series installation requirements are kept to an absolute minimum, for example you can create a daisy-chain application with no software configuration whatsoever. More extensive configuration is available through the built-in web interface.

The web interface allows total control of all functions and can provide a comprehensive set of screen diagnostics and statistics. The units also support SNMP allowing them to be managed as part of the overall network infrastructure.

The DDW 1xx series are simple point to point devices that can be configured at the flick of a single DIP switch only.

These units have no internal configuration web pages, but the DDW-120 is provided with a comprehensive diagnostic tool to aid installation.

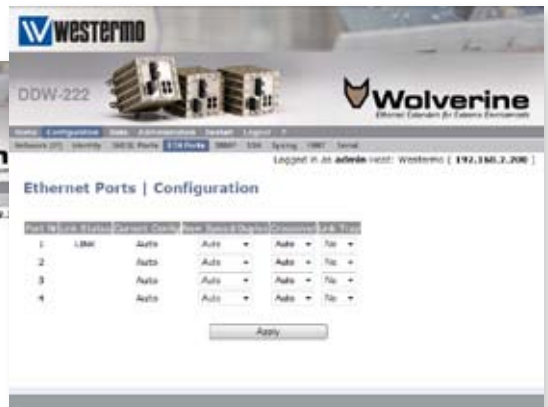
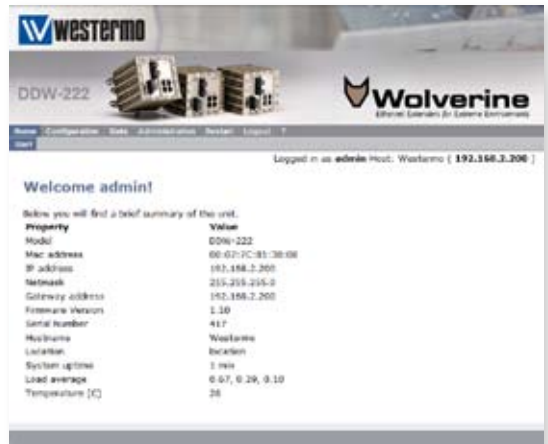

DDW-22x web interface

# Approvals



⌘ The Wolverine series has gone through extensive testing and approvals both by Westermo and approved test houses. The units are designed and type tested based on:

- Electromagnetic Compatibility, EMC (2004/108/EC)
- Equipment explosive atmospheres, ATEX (94/9/EC) \* *Note 1*
- Immunity for residential, commercial and light-industrial environments (EN 61000-6-1)
- Immunity for industrial environments (EN 61000-6-2)
- Emission standard for industrial environments (EN 61000-6-4)
- Information technology equipment – Immunity (EN 55024)
- Railway applications – Electromagnetic compatibility – Emission and immunity of the signalling and telecommunications apparatus (EN 50121-4)
- Electrical apparatus for explosive gas atmospheres – General requirements (EN 60079-0) \* *Note 1*
- Electrical apparatus for explosive gas atmospheres – Construction, test and marking of type of protection “n” electrical apparatus (EN 60079-15) \* *Note 1*
- Radio frequency devices (FCC part 15 Class A)
- SHDSL approval (ITU-T G.991.2)
- MTBF calculated according to MIL-HDBK- 217F
- Degree of protection according to IEC529 (IP)
- Isolation test, all interfaces tested according to EN60950
- Vibration test according to IEC 60068-2-6
- Shock test according to IEC 60068-2-27
- Temperature / Humidity / Altitude according to Westermo environmental conditions

\* *Note 1 holds for DDW-220, DDW-221 and DDW-222*

# Wolverine in explosive environments



The DDW-220, DDW-221 and DDW-222 have been designed to meet the ATEX approval which is a directive that covers both equipment and protective systems used in potentially explosive atmospheres. The directive was adopted by the European Union to facilitate free trade in the EU and the EEA by aligning the technical and legal requirements for products intended for use in potentially explosive atmospheres. Atmospheres where gas, mist, vapour and dust may occur in such concentration that it would become explosive in a normal oxygen environment and could be ignited by hot surfaces, electrically generated sparks, electrostatic discharge, radio and electromagnetic waves, stray electrical or leakage currents. Although the ATEX Directive was originally developed by the European Union, it is now being applied all over the world.

In this Directive, equipment is considered to be any device that contains a potential ignition source and requires special measures to be incorporated in its design or application to prevent ignition.

The DDW-220, DDW-221 and DDW-222 have been ATEX approved according to **II 3G EEx nA IIT5** and can be fitted in Zone 2 environments. For more information on explosive environments and the ATEX approval, please refer to the section on ATEX in the Wolverine white paper.

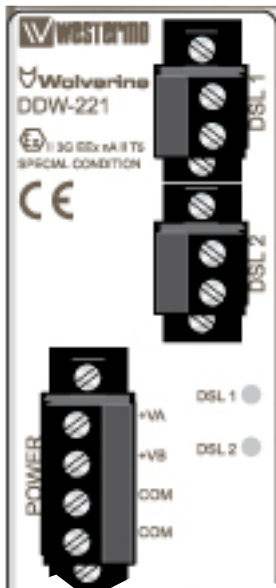

DDW-220  
 DDW-221  
 DDW-222  
 ATEX approved according to II 3G EEx nA IIT5

- ⌘ Transparent Ethernet Extender
- ⌘ Data rates up to 5.7 Mbit/s
- ⌘ Up to 10 km (6.2 miles) on twisted pair
- ⌘ Plug and Play
  - Auto MDI/MDI-X
  - Auto negotiation
  - Auto polarity
- ⌘ 10/100BaseTX
- ⌘ Settings for:
  - Reliable Mode.
  - High speed mode
  - Normal mode
- ⌘ Wide temperature range (-25°C to +70°C)
- ⌘ Comprehensive diagnostics
- ⌘ Total galvanic isolation & transient protection
- ⌘ Industrial and Railway approval
- ⌘ Redundant power and wide DC input range
- ⌘ MTBF 600 000 hours

# DDW-100

## Industrial Ethernet Extender

The DDW-100 is a plug and play Industrial Ethernet SHDSL extender. It is designed as a transparent Ethernet Extender for 10/100BaseTX networks. SHDSL represents the best of several symmetric DSL technologies. This unit provides the ability to re-use existing twisted copper pair with data rates from 192 kbit/s to 2.3 Mbit/s in both directions up to 10 km (6.2 miles).

The DDW-100 is a bridge not router and so is simple to install with all configuration done by DIP-switches.

The DIN rail mounted DDW-100 can be powered from two separate supplies and handle an operating voltage range of 10–60 VDC.

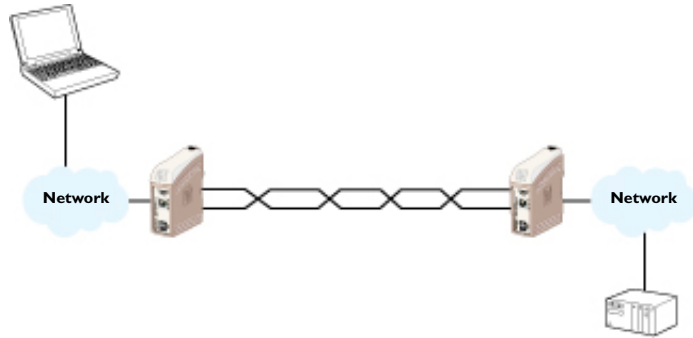

# DDW-120

## Industrial Ethernet Extender

The DDW-120 Ethernet Extender is the ideal solution for extending your Ethernet network over copper cables where in the past the only option would have been fibre. At shorter ranges the data rate will be as high as 5.7 Mbit/s in both directions. The technology used suggests transmission distances of up to 10 km (6.2 miles) at lower data rates. In practical applications however much greater distances have been achieved.

The SHDSL transmission technology makes the DDW-120 perfect for the re-use of existing copper cable installations from older communications networks. It is transparent for multicast addressing, VLAN packets, allows VPN pass-through for IPSec and can be used with protocols like MODBUS/TCP and Profinet I/O. The units will auto negotiate the transmission speed but can also be forced to choose a slower (more reliable) or faster (less reliable) data rate.

DDW-120 can be used in point-to-point applications or as start or termination unit together with the DDW-220/221/222 in daisy-chain applications.

The Link Fault Forward (LFF) function allows the DDW-120 to be used in large redundant networks where connected devices such as routers need to know if media failure has occurred. If the SHDSL line fails the UTP port can forward this information over the Ethernet link.

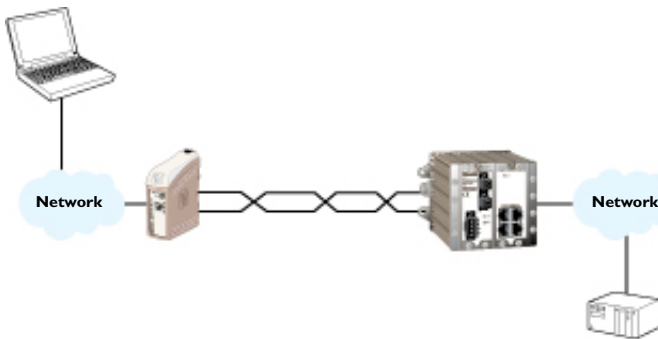

- ⌘ Transparent Ethernet Extender
- ⌘ Data rates up to 5.7 Mbit/s
- ⌘ Up to 10 km (6.2 miles) on twisted pair
- ⌘ LFF (Link Fault Forward)
- ⌘ Plug and Play
  - Auto MDI/MDI-X
  - Auto negotiation
  - Auto polarity
- ⌘ 10/100BaseTX
- ⌘ Settings for:
  - Reliable Mode
  - High speed mode
  - Normal mode
- ⌘ Wide temperature range (-40°C to +70°C)
- ⌘ Comprehensive diagnostics
- ⌘ Total galvanic isolation & transient protection
- ⌘ Industrial and Railway approval
- ⌘ Redundant power and wide DC input range
- ⌘ MTBF 600 000 hours



- ⌘ Plug and play
- ⌘ Data rates up to 5.7 Mbit/s
- ⌘ Up to 10 km (6.2 miles) on twisted pair
- ⌘ Extensive line protection
- ⌘ 2 x SHDSL
- ⌘ SNMP and comprehensive diagnostic
- ⌘ 16 – 60 VDC power supply
- ⌘ Reverse polarity protection
- ⌘ 4 ports Ethernet switch
- ⌘ Web interface
- ⌘ MTBF 700 000 hours at 25 °C
- ⌘ Made for extreme environments
  - – 40 °C to +70 °C
  - Metal housing
  - IP 40
  - DIN mounting



II 3G EEx nA II T5  
SPECIAL CONDITON

# DDW-220

## Industrial Ethernet Extender

The DDW-220 is an Industrial Ethernet SHDSL extender is the ideal solution for extending your Ethernet network over copper cables where in the past the only option would have been fibre. At shorter range the transfer rate will be as fast as 5.7 Mbit/s

in both directions. The technology used suggests transmission distances of up to 10 km (6.2 miles) at lower data rates. In practical applications however much greater distances have been achieved.

The SHDSL transmission technology makes the DDW-220 perfect for the re-use of existing copper cable installations from older communications networks. The Ethernet Extender has got two SHDSL interfaces and can therefore be used to create a daisy-chain network.

The units will auto negotiate the transmission speed but can also be forced to choose a slower (more reliable) or faster (less reliable) data rate. With it's built in four-port Ethernet switch the DDW-220 is the only unit required to build a complete Ethernet solution. The DDW-220 can be used together with DDW-120.

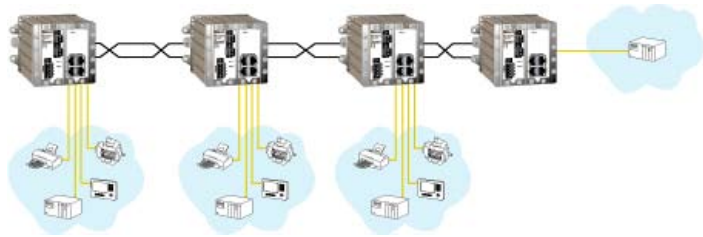

# DDW-221

## Redundant Ring Ethernet Extender

The DDW-221 is an Industrial Ethernet SHDSL extender with support for redundant rings. The redundant protocol can be used either on the SHDSL interface or on the Ethernet interface. Our unique FRNT (Fast Recovery of Network Topology) technology is the fastest protocol on the market to re-configure a network in the event of any failure of a link or hardware.

The DDW-221 Ethernet Extender is the ideal solution for extending your Ethernet network over copper cables where in the past the only option would have been fibre. At shorter range the transfer rate will be as fast as 5.7 Mbit/s in both directions. The technology used suggests transmission distances of up to 10 km (6.2 miles) at lower data rates. In practical applications however much greater distances have been achieved.

The SHDSL transmission technology makes the DDW-221 perfect for the re-use of existing copper cable installations from older communications networks. The Ethernet Extender supports two SHDSL interfaces and can therefore be used to create a daisy chain or ring network.

The units will auto negotiate the transmission speed but can also be forced to choose a slower (more reliable) or faster (less reliable) data rate. With its built in four-port Ethernet switch the DDW-221 is the only unit required to build a complete Ethernet solution.

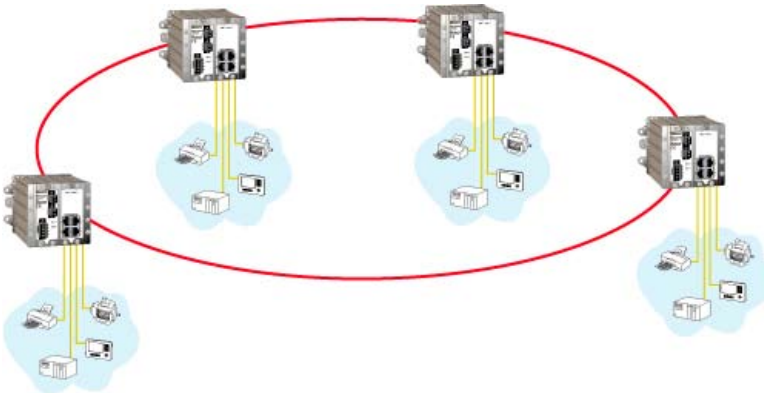

- ⌘ Redundant protocol (FRNT) on SHDSL or on the Ethernet switch
- ⌘ Plug and play
- ⌘ Data rates up to 5.7 Mbit/s
- ⌘ Up to 10 km (6.2 miles) on twisted pair
- ⌘ Extensive line protection
- ⌘ 2 x SHDSL
- ⌘ SNMP and comprehensive diagnostic
- ⌘ 16 – 60VDC power supply
- ⌘ Reverse polarity protection
- ⌘ 4 ports Ethernet switch
- ⌘ Web interface
- ⌘ MTBF 700 000 hours at 25° C
- ⌘ Made for extreme environments
  - – 40°C to +70°C
  - Metal housing
  - IP 40
  - DIN mounting



II 3G EEx nA II T5  
SPECIAL CONDITON



- ⌘ RS-232 serial adapter
- ⌘ 10 port Virtual Com software
- ⌘ Redundant protocol (FRNT) on SHDSL or on the Ethernet switch
- ⌘ Plug and play
- ⌘ Data rates up to 5.7 Mbit/s
- ⌘ Up to 10 km (6.2 miles) on twisted pair
- ⌘ Extensive line protection
- ⌘ 2 x SHDSL
- ⌘ SNMP and comprehensive diagnostic
- ⌘ 16 – 60VDC power supply
- ⌘ Reverse polarity protection
- ⌘ 4 ports Ethernet switch
- ⌘ Web interface
- ⌘ MTBF 700 000 hours at 25 °C
- ⌘ Made for extreme environments
  - – 40°C to +70°C
  - Metal housing
  - IP 40
  - DIN mounting



II 3G EEx nA II T5  
SPECIAL CONDITON



# DDW-222

## Legacy Serial Redundant Ring Ethernet Extender

The DDW-222 is an Industrial Ethernet SHDSL extender with support for redundant rings. The redundant protocol can be used either on the SHDSL interface or on the Ethernet interface. Our unique FRNT (Fast Recovery of Network Topology) technology is the fastest protocol on the market to re-configure a network in the event of any failure of a link or hardware. Also included in the DDW-222 is a RS-232 serial adapter and a 10-port Virtual Com port re-director software. The unit supports TCP client, TCP server and UDP protocol modes allowing it to be used in a wide variety of applications.

The DDW-222 allows the cables of existing serial networks to be reused to create an Ethernet network while still allowing the legacy serial device to function on the new network.

The DDW-222 Ethernet Extender is the ideal solution for extending your Ethernet network over copper cables where in the past the only option would have been fibre. At shorter range the transfer rate will be as fast as 5.7 Mbit/s in both directions. The technology used suggests transmission distances of up to 10 km (6.2 miles) at lower data rates. In practical applications however much greater distances have been achieved. The SHDSL transmission technology makes the DDW-222 perfect for the re-use of existing copper cable installations from older communications networks. The Ethernet Extender supports two SHDSL interfaces and can therefore be used to create a daisy chain or ring network.

The units will auto negotiate the transmission speed but can also be forced to choose a slower (more reliable) or faster (less reliable) data rate. With its built in four-port Ethernet switch the DDW-222 is the only unit required to build a complete Ethernet solution.

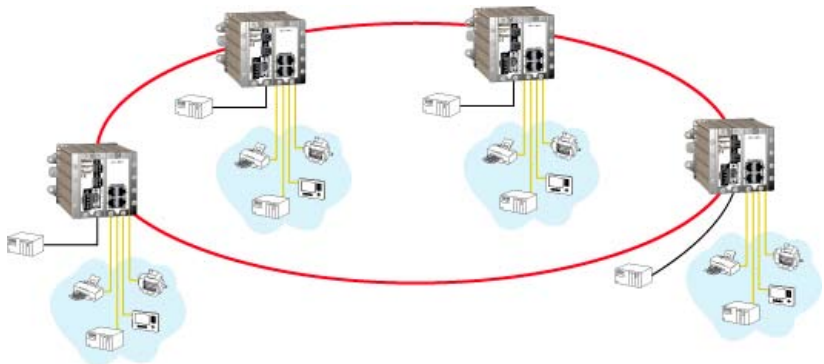



## Success Stories



# Amsterdam gas and energy distribution



Alliander (formerly Nuon) is one of the biggest energy suppliers in the Netherlands with 2,5 million customers in the Netherlands and Belgium. They generate electricity (20TWh yearly, green and grey ) and distribute it, as well as gas to a major part of the Dutch domestic and industrial market.

One of the divisions of Alliander is Liandong (formerly Nuon Tecno). This engineering and project management division were contracted to provide a telemetry system for the gas network in Amsterdam.

Amsterdam has a large number of gas-substations where Alliander can regulate the gas distribution network for the Dutch capital. There was however a requirement to not only regulate, but also monitor in real-time usage, alarms and flow measurement. With this information Alliander can deliver better services to their customers and reduce cost. For the remote telemetry unit Alliander chose a new RTU, the D05-MCU-IEC from Data watt Telecontrol Systems that utilizes the Ethernet based IEC 60870-5-104 communication protocol. Using fibre-optic cabling for the Ethernet communications would have been the logical choice because many of the Ethernet links would exceed the maximum 100 m (328 ft) range for UTP cable. Fibre would however be too expensive and nearly impossible to install in a short time frame and in a crowded city. The solution was simple; make use of the existing copper cabling which already existed in

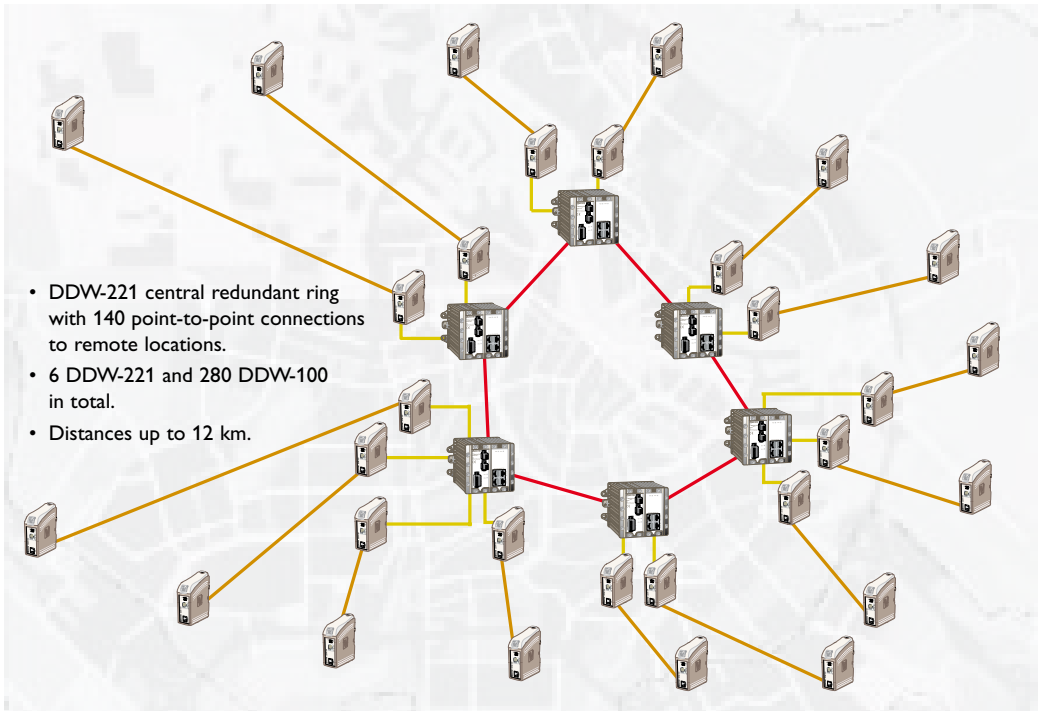

Alliander's own telecom and signalling cable network. After some successful tests with the Westermo DDW-100 and our previous experiences using the Westermo modem family, Alliander made a choice to use the Westermo Ethernet Extender products. Stated Mr. Rens Dekker, Senior Engineer BOS. The key specifications were the galvanic isolation, extended temperature and performance of the DSL-line. Tests were done up to 17 km (10.6 mi). Alliander is using a ring of DDW-221s to form a central, redundant ring. From this central ring 140 point-to-point communication lines are used to connect the remote locations (gas substations). Each point-to-point link consists of two DDW-100s to extend the Ethernet link up to a maximum of 12 km (7.5 mi). In total Alliander will install 6 DDW-221s and 280 DDW-100s to upgrade its gas distribution system into a modern, SCADA controlled and monitored communication system.

**Company data:**

Dutch energy company that serves more than 2,5 million private and business customers in the Netherlands, Belgium and Germany.

Provided by:



# Highway tunnel emergency system



The A14 highway links the Paris business district of La Défense with Orgeval. The highway is mainly underground and the total tunnel length is more than 13 km. Technical supplier SDEL was selected to provide the tunnels with an emergency system. There are eight tunnels in total, and at each tunnel entrance SDEL designed a message sign and road barrier system to stop the traffic in case of an emergency.

A central redundant fibre network built with Lynx switches provides a backbone for a number of DDW-221 SHDSL sub-networks that control the message signs. The backbone network and the sub-networks all use the Westermo FRNT redundancy protocol. This design delivers a redundant system that provides high availability, reliability, and safety which were the major factors in the customers decision to use the Westermo Lynx and DDW-221.

- Lynx central redundant fibre network
- DDW-221 SHDSL sub-networks
- FRNT redundancy protocol

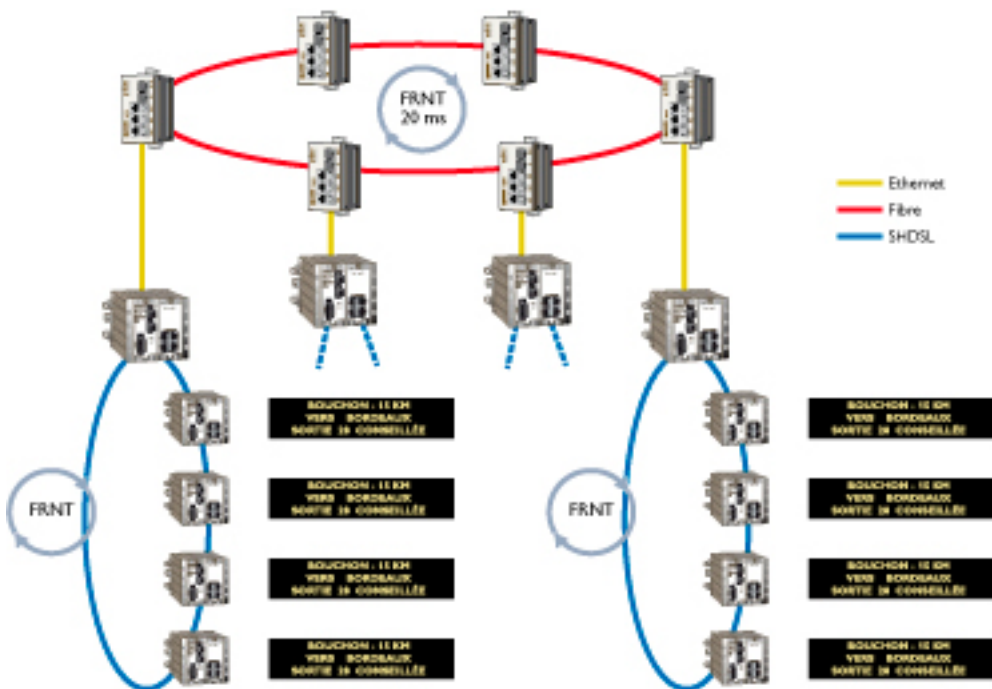

# Fresh water distribution and wastewater treatment



Suez Lyonnaise des Eaux is a global utility company who amongst other services provides drinking water and wastewater collection systems to much of France.

INEO Suez - an electrical and communication company was entrusted with a project to provide a secure redundant network to connect a number of pump stations in a particular region of France. The DDW-100 Ethernet extender was chosen to provide the connectivity between the pump stations and the R-208 switch used to manage the redundancy. About 100 DDW-100 and 16 R-208 have been used to date in this highly successful project, which demonstrates Westermo's ability to support major infrastructure projects.

**Company data:**

Provides drinking water and waste water treatment for millions of private customers in France.



- Complete redundant system connecting to a number of pump stations
- Approx 100 DDW-100 and 16 R-208

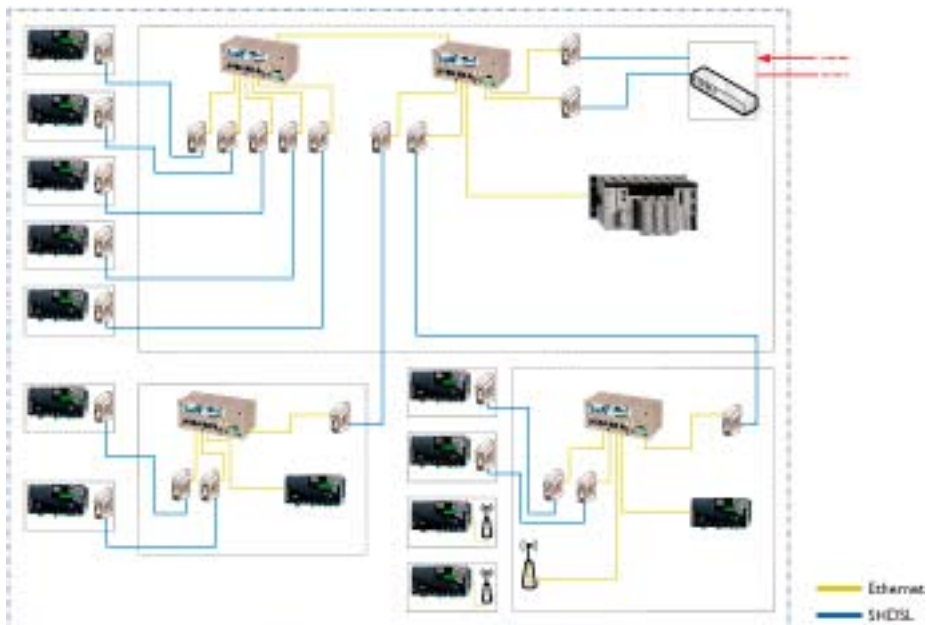

The diagram shows a small part of the complete installation.



## Gross Automation

3680 N. 126th St  
Brookfield, WI 53005

ph: 262.252.1600

fax: 262.252.1616

[www.grossautomation.com](http://www.grossautomation.com)