

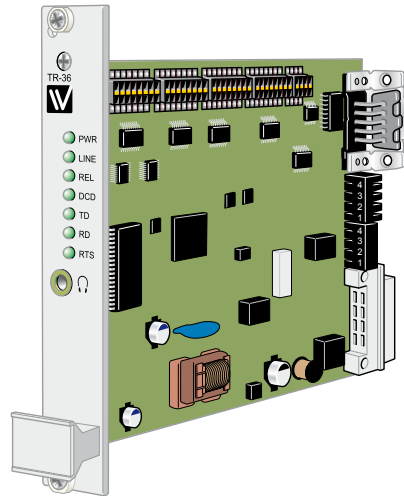

TR-36



***Tele and leased line modem
for RV-07 19" rack system***

Legal information

The contents of this document are provided "as is". Except as required by applicable law, no warranties of any kind, either express or implied, including, but not limited to, the implied warranties of merchantability and fitness for a particular purpose, are made in relation to the accuracy and reliability or contents of this document. Westermo reserves the right to revise this document or withdraw it at any time without prior notice.

Under no circumstances shall Westermo be responsible for any loss of data or income or any special, incidental, and consequential or indirect damages howsoever caused.

More information about Westermo can be found at the following Internet address:
<http://www.westermo.com>

Safety



Before installation:

This modem is for restricted access area use only

Read this manual completely and gather all information on the unit. Make sure that you understand it fully. Check that your application does not exceed the safe operating specifications for this unit.

This unit should only be installed by qualified personnel.

This unit should be built-in to an apparatus cabinet, or similar, where access is restricted to service personnel only.

The power supply wiring must be sufficiently fused, and if necessary it must be possible to disconnect manually from the power supply. Ensure compliance to national installation regulations.

This unit uses convection cooling. To avoid obstructing the airflow around the unit, follow the spacing recommendations (see Cooling section).



Before mounting, using or removing this unit:

Prevent access to hazardous voltage by disconnecting the unit from power supply and all other electrical connections.

Warning! Do not open connected unit. Hazardous voltage may occur within this unit when connected to power supply or TNV circuits.

Prevent access to hazardous voltage by disconnecting the unit from power supply.

Warning! Do not open connected unit. Hazardous voltage may occur within this unit when connected to power supply or TNV circuits.

Care recommendations

Do not drop, knock or shake the unit, rough handling above the specification may cause damage to internal circuit boards.

Do not use harsh chemicals, cleaning solvents or strong detergents to clean the unit.

Do not paint the unit. Paint can clog the unit and prevent proper operation.

Do not expose the unit to any kind of liquids (rain, beverages, etc). The unit is not waterproof. Keep the unit within the specified humidity levels.

Do not use or store the unit in dusty, dirty areas, connectors as well as other mechanical part may be damaged.

If the unit is not working properly, contact the place of purchase, nearest Westermo distributor office or Westermo Tech support.

Maintenance

No maintenance is required, as long as the unit is used as intended within the specified conditions.

Agency approvals and standards compliance

Type	Approval / Compliance
EMC	EN 61000-6-2, Immunity industrial environments
	EN 55024, Immunity IT equipment
	EN 61000-6-3, Emission industrial environments
Safety	EN 60950-1, IT equipment
PSTN	ETSI TS103 021-1, ETSI TS103 021-2, ETSI TS103 021-3

Declaration of Conformity



Westermo Teleindustri AB

Declaration of conformity

The manufacturer Westermo Teleindustri AB
SE-640 40 Stora Sundby, Sweden

Herewith declares that the product(s)

Type of product	Model	Art no	Installation manual
Rack mounted Tele and Leased Line modem	TR-36	3614-0500	6614-2201
Rack	RV-07	3130-3001	6614-2201
Rack	PS-20 HV	3120-3101	6614-2201

is in conformity with the following EC directive(s).

No	Short name
89/336/EEG	Electromagnetic Compatibility (EMC)
73/23/EEG	Low Voltage Directive - LVD

References of standards applied for this EC declaration of conformity.

No	Title	Issue
EN 61000-6-2	Immunity for industrial environments	2 (2001)
EN 55024	Information technology equipment – Immunity	1 (1998)
EN 61000-6-3	Emission standard for industrial environments	1 (2001)
EN 60950	Safety of information technology equipment	6 (2000)
EN 50121-4	Railway signalling and telecommunications apparatus	
IEC 62236-4	Railway signalling and telecommunications apparatus	

The last two digits of the year in which the CE marking was affixed: 07

Hans Levin
Technical Manager
26th September 2007

Postadress/Postal address
S-640 40 Stora Sundby
Sweden

Tel. 016-428000
Int+46 16428000

Telefax 016-428001
Int+46 16428001

Postgiro 52 72 79-4

Bankgiro 5671-5550

Org.nrf
Corp. identity number
556361-2604

Registered office
Eskilstuna

Type tests and environmental conditions

Electromagnetic Compatibility			
Phenomena	Test	Description	Test levels
ESD	EN 61000-4-2	Enclosure contact	± 6 kV
		Enclosure air	± 8 kV
RF field AM modulated	IEC 61000-4-3	Enclosure	10 V/m 80% AM (1 kHz), 80 – 1 000 MHz 20 V/m 80% AM (1 kHz), 80 – 2 000 MHz
RF field 900 MHz	ENV 50204	Enclosure	20 V/m pulse modulated 200 Hz, 900 ± 5 MHz
Fast transient	EN 61000-4-4	Signal ports	± 2 kV
		Power ports	± 2 kV
Surge	EN 61000-4-5	Signal ports unbalanced	± 2 kV line to earth, ± 2 kV line to line
		Signal ports balanced	± 2 kV line to earth, ± 1 kV line to line
		Power ports	± 2 kV line to earth, ± 2 kV line to line
RF conducted	EN 61000-4-6	Signal ports	10 V 80% AM (1 kHz), 0.15 – 80 MHz
		Power ports	10 V 80% AM (1 kHz), 0.15 – 80 MHz
Power frequency magnetic field	EN 61000-4-8	Enclosure	100 A/m, 50 Hz, 16.7 Hz & 0 Hz
Pulse magnetic field	EN 61000-4-9	Enclosure	300 A/m, 6.4 / 16 ms pulse
Voltage dips and interruption	EN 61000-4-11	AC power ports	10 & 5 000 ms, interruption 10 & 500 ms, 30% reduction 100 & 1 000 ms, 60% reduction
Mains freq. 50 Hz	EN 61000-4-16	Signal ports	100 V 50 Hz line to earth
Mains freq. 50 Hz	SS 436 15 03	Signal ports	250 V 50 Hz line to line
Voltage dips and interruption	EN 61000-4-29	DC power ports	10 & 100 ms, interruption 10 ms, 30% reduction 10 ms, 60% reduction +20% above & -20% below rated voltage
Radiated emission	EN 55022	Enclosure	Class B
Conducted emission	EN 55022	AC power ports	Class B
	EN 55022	DC power ports	Class B
Dielectric strength	EN 60950	Signal port to other isolated ports	2 kVrms 50 Hz 1 min
		Power port to other isolated ports	3 kVrms 50 Hz 1 min 2 kVrms 50 Hz 1 min (@ rated power <60 V)
Environmental			
Temperature		Operating	0 to +50°C
		Storage & Transport	-25 to +70°C
Humidity		Operating	5 to 95% relative humidity non condensing.
		Storage & Transport	5 to 95% relative humidity non condensing.
Altitude		Operating	2 000 m / 70 kPa
Reliability prediction (MTBF)	MIL-HDBK-217F	Operating	
Service life		Operating	10 year
Packaging			
Enclosure	–	–	–
Dimension W x H x D			485 x 135 x 180 mm
Weight TR-36			0.14 kg
Weight Total (17 TR-36 + 2 PS-20)			4 kg
Degree of protection	IEC 529	Enclosure	IP 20
Cooling			Convection
Mounting			19" rack

Description

TR-36 is designed to satisfy industry's demands on reliability and functionality in environments with high levels of interference. The modem has an RS-232 interface and works both as calling/answering and on 2- or 4-wire leased line. TR-36 can handle rates up to 115.2 kbit/s on the terminal side and up to 33.6 kbit/s on the line side. Specific parameters can also be set in hardware using DIP-switches.

The modem is equipped with transient protection on the line side and a "watchdog" that monitors and automatically resets the modem in the event of a fault. These functions together with the possibility for remote configuration makes the modem perfect for installation at unmanned sites and prevent the need of costly service trips.

The modem also has password protection and dial-back security to ensure that only authorised users can communicate with the modem.

TR-36 is intended for RV-07 19" rack system.

In the TR-36 there is also an RS422/485 interface allowing multidrop connections to many types of industrial equipment.

- ⌘ Data rate up to 33.6 kbit/s with Fast Connect
- ⌘ Terminal rate up to 115.2 kbit/s
- ⌘ 2- and 4-wire leased line
- ⌘ V23 HDX with multidrop
- ⌘ DTR and incoming data dialling
- ⌘ DIP-switch configuration
- ⌘ Watchdog
- ⌘ Secure call back and access
- ⌘ Industrial environment transient protection on all interfaces
- ⌘ Up to 11 bits
- ⌘ Tri-Galvanic isolation (interface/line/supply)
- ⌘ Caller ID presentation and answering
- ⌘ Remote configuration
- ⌘ RS-422 / RS-485 interface
- ⌘ Dial backup for PSTN and Leased Line

Interface specifications

Power RV-07, 17 pcs TR-36, PS-20 HV	
Power supply	110 – 250 VDC +10 / –10% 115 – 230 VAC +15 / –10%
Power consumption	500/240 mA, 50 W
Rated frequency	DC / 48 – 62 Hz
Fuse, F1	4 AS 5x 20 mm
Isolation to	All other ports 3 kV _{rms} 50 Hz 1 min
Connection	Detachable screw terminal
Shielded cable	Not required

* Direction relative this unit

Power RV-07, 17 pcs TR-36, ext 24 – 48 VDC	
Power supply	24 – 48 VDC
Power consumption	34 W
Rated frequency	DC
Isolation to	All other ports 1.5 kV _{rms} 50 Hz 1 min
Connection	Detachable screw terminal ^{**}
Shielded cable	Not required

* Direction relative this unit

** Maximum wire length to external power supply < 10 m.

Public Switched Telephone Network (PSTN)	
Electrical specification	Public Switched Telephone Network
Data rate	300 bit/s – 33.6 kbit/s
Protocol	B103, B212, V21, V22, V22B, V23C, V23HDX, V32, V32B, V34
Protection	Installation Fault Tolerant (up to ±60 V)
Isolation to	Power port 3 kV _{rms} 50 Hz 1 min Leased line 2 kV _{rms} 50 Hz 1 min RS-232 2 kV _{rms} 50 Hz 1 min RS-485 2 kV _{rms} 50 Hz 1 min
Connection	Detachable screw terminal
Shielded cable	Not required

Leased Line (LL)	
Electrical specification	2- or 4-wire Leased Line
Data rate	300 bit/s – 33.6 kbit/s
Protocol	B103, B212, V21, V22, V22B, V23C, V23HDX, V23FDX, V32, V32B, V34
Transmission range/ Budget	PSTN 30 dB Leased line 40 dB
Protection	Installation Fault Tolerant (up to ± 60 V)
Isolation to	Power port 3 kV _{rms} 50 Hz 1 min PSTN line 2 kV _{rms} 50 Hz 1 min RS-232 2 kV _{rms} 50 Hz 1 min RS-485 2 kV _{rms} 50 Hz 1 min
Connection	Detachable screw terminal
Shielded cable	Not required
RS-422/485	
Electrical specification	EIA/TIA-485 ITU V.112-wire or 4-wire twisted pair
Data rate	1200 bit/s – 115.2 kbit/s
Data format	7 or 8 data bits, Odd, even or none parity, 1 or 2 stop bits, Σ 9–12 bits
Protocol	Transparent
Retiming	Yes
Turn around time	<10 μ s (half duplex)
Transmission range	1200 m, depending on data rate and cable type (EIA RS-485)
Settings	120 Ω termination and failsafe biasing 680 Ω
Protection	Installation Fault Tolerant (up to ± 60 V)
Isolation to	Power port 3 kV _{rms} 50 Hz 1 min PSTN line 2 kV _{rms} 50 Hz 1 min Leased line 2 kV _{rms} 50 Hz 1 min
Connection	Detachable screw terminal
Shielded cable	Not required*
Miscellaneous	Do not connect RS-232 and RS-422/485 simultaneously

* To minimise the risk of interference, a shielded cable is recommended when the cable is located inside 3 m boundary to the rails and connected to this port.
The cable shield should be properly connected (360°) to an earthing point within 1 m from this port. This earthing point should have a low impedance connection to the conductive enclosure of the apparatus cabinet, or similar, where the unit is built-in. This conductive enclosure should be connected to the earthing system of an installation and may be directly connected to the protective earth.

RS-232	
Electrical specification	EIA/TIA-232
Data rate	1 200 bit/s – 115.2 kbit/s
Data format	7 or 8 data bits, Odd, even or none parity, 1 or 2 stop bits; Σ 9–12 bits
Protocol	Transparent
Retiming	Yes
Transmission range	Cable length ≤15 m
Isolation to	Power port 3 kV _{rms} 50 Hz 1 min PSTN line 2 kV _{rms} 50 Hz 1 min Leased line 2 kV _{rms} 50 Hz 1 min
Connection	9-pin D-sub female (DCE) and Detachable screw terminal (DCE)
Connector size	Detachable screw terminal 0.2 – 2.5 mm ² (AWG 24 – 12)
Shielded cable	Not required*
Conductive housing	Isolated to all other circuits
Miscellaneous	Do not connect RS-232 and RS-422 / 485 simultaneously

* To minimise the risk of interference, a shielded cable is recommended when the cable is located inside 3 m boundary to the rails and connected to this port.

The cable shield should be properly connected (360°) to an earthing point within 1 m from this port.

This earthing point should have a low impedance connection to the conductive enclosure of the apparatus cabinet, or similar, where the unit is built-in. This conductive enclosure should be connected to the earthing system of an installation and may be directly connected to the protective earth.

Connections

TR-36

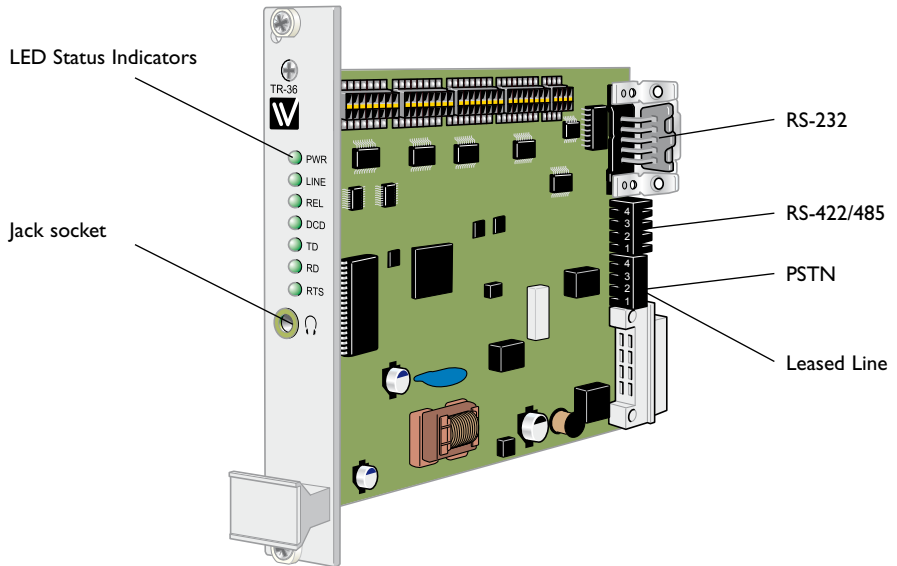

Power

Position	Direction*	Description	Product marking
1	In	AC: Neutral DC: - Voltage	
2	In	AC: Line DC: + Voltage	

To minimise the risk of interference, a shielded cable is recommended when the cable is located inside 3 m boundary to the rails and connected to this port.

The cable shield should be properly connected (360°) to an earthing point within 1 m from this port. This earthing point should have a low impedance connection to the conductive enclosure of the apparatus cabinet, or similar, where the unit is built-in. This conductive enclosure should be connected to the earthing system of an installation and may be directly connected to the protective earth.

PSTN

Position	Direction*	Description
Screw terminal*		
2	In/Out	PSTN Transmit/ Receive
1	In/Out	PSTN Transmit/ Receive

* The PSTN screw terminals are shared with 2-wire Leased line

Leased Line

Position	Direction*	Description
1	Out	4-wire Transmit
	In/Out	2-wire Receive/ Transmit
2	Out	4-wire Transmit
	In/Out	2-wire Receive/ Transmit
3	In	4-wire Receive
	In/Out	2-wire Receive/ Transmit at Leased line PSTN backup
4	In	4-wire Receive
	In/Out	2-wire Receive/ Transmit at Leased line PSTN backup

* Direction relative this unit

RS-422/485

Position	Direction	Description	Product marking
1	In	R+ (A') Receive RS-422/485 4-wire	R+
2	In	R- (B') Receive RS-422/485 4-wire	R-
3	Out	T+ (A) Transmit RS-422/485 4-wire	T/R+
	In/Out	T+ (A/A') Transmit/Receive RS-485 2-wire	
4	Out	T- (B) Transmit RS-422/485 4-wire	T/R-
	In/Out	T+ (A/A') Transmit/Receive RS-485 2-wire	

RS-232 (DCE)

Position	D-sub	Direction*	Description	Product marking
1		Out	Data Carrier Detect (DCD)	DCD
2		Out	Received Data (RD)	RD
3		In	Transmitted Data (TD)	TD
4		In	Data Terminal Ready (DTR)	DTR
5		-	Signal Ground (SG)	SG
6		Out	Data Set Ready (DSR)	DSR
7		In	Request To Send (RTS)	RTS
8		Out	Clear To Send (CTS)	CTS
9		Out	Ring Indicator (RI)	RI

* Direction relative this unit

LED indicators

LED	Status	Indication of
RTS	OFF	RTS signal is inactive
	ON	RTS signal is active
RD	OFF	No data
	ON / FLASH	The modem transmitting data on the DTE interface
TD	OFF	No data
	ON / FLASH	The modem receiving data on the DTE interface
DCD	OFF	DCD signal is inactive
	ON	DCD signal is active, modem has detected a carrier or the signal is set to always on
REL	OFF	Reliable mode is off, direct or normal mode
	ON	Reliable mode is on
	FLASH	Reliable mode with error correction and compression
LINE	OFF	The modem is on-hook
	ON	The modem is off-hook with a established connection
	FLASH	Line backup interface in use
PWR	OFF	The modem has no power
	ON	The modem is up and running

DIP-switch settings



Before DIP-switch settings:

Prevent damage to internal electronics from electrostatic discharges (ESD) by discharging your body to a grounding point (e.g. use of wrist strap).

NOTE DIP-switch alterations are only effective after a power on.

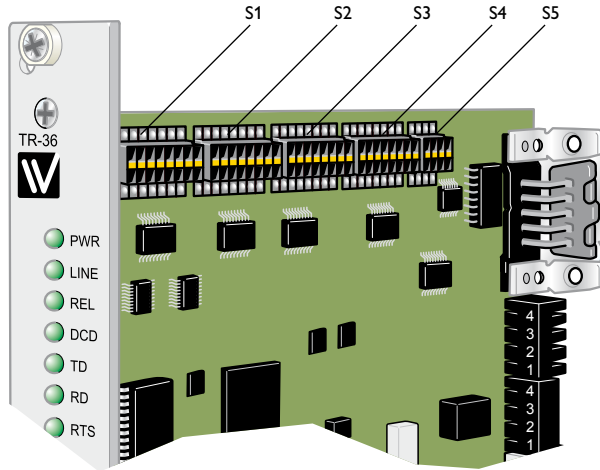

S1 DIP-switch Stored values / Auto detect

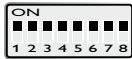

Use stored values



Auto detect*

* 300 and 600 bit/s not supported

S1 DIP-switch Selection of DTE speed



300 bit/s



9600 bit/s



600 bit/s

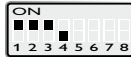

19.2 kbit/s



1200 bit/s



38.4 kbit/s



2400 bit/s



57.6 kbit/s



4800 bit/s



115.2 kbit/s

S1 DIP-switch

Selection of DTE format



7E 1S

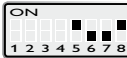

7E 2S



7O 1S



7O 2S

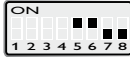

8N 1S

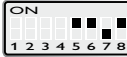

8N 2S



8E 1S



8E 2S

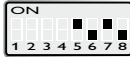

8O 1S

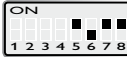

8O 2S



Direct mode 8E1 or 8O1
8O1 in command mode



Direct mode 8E2 or 8O2
8N2 in command mode



Direct mode 7E1 or 7O1
8N1 in command mode



Direct mode 7E2 or 7O2.
8N2 in command mode



7N 2S

S2 DIP-switch

Leased Line Mode selection

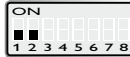

Leased line disable,
PSTN enable

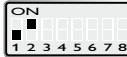

Leased line answering



Leased line V.23 multidrop
For V.23 Multidrop settings,
see selection below.



Leased line calling

S2 DIP-switch

DTE interface Selection



RS-422/485 disable,
RS-232 enable



RS-422/485 enable,
RS-232 disable

**S2 DIP-switch
RS-422/485**



RS-422/485, 2-wire



RS-422/485, 4-wire

**S2 DIP-switch
Leased line 2/4 wire selection**



Leased line 2-wire



Leased line 4-wire

**S2 DIP-switch
Selection PSTN backup of Leased line**



Backup of leased line disabled



Backup of leased line enabled

**S2 DIP-switch
Selection of answering/calling mode for PSTN backed up Leased Line**



Answering



Calling

**S2 DIP-switch
Remote configuration control**



Use stored values



Remote configuration disabled

S3 DIP-switch

Selection of line speed and modulation

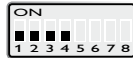

Use saved parameters defined by AT+MS



V.34, 1 9600

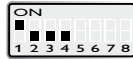

V.21 300



V.32bis 14400



V.23 1200 hdx



V.34 19200



V.22 1200



V.34 24000

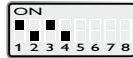

V.22bis 2400



V.34 28 800

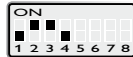

V.32bis 4800



V.34 33600



V.32bis, 1 9600



Automatic line speed



V.32bis 9600

S3 DIP-switch

PLC parameter setting



Use stored values



PLC settings (ATQ1E0&C1&K0&A1)

S3 DIP-switch

Flow control DTE interface

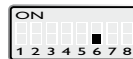

Use stored value for AT&Kn

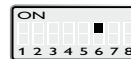

RTS/CTS flow control enable (AT&K3)

S3 DIP-switch

Dial abort



Use stored values



Dial abort disabled (AT&A1)

S3 DIP-switch

Blind dialing

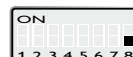

Use stored values



Enable blind dialing (ATX3)

S4 DIP-switch
Set modem to factory default



Use stored values

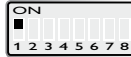

Restore factory default setting*

Don't leave S4:1 in ON position if not intended to restore factory setting at every power on.

S4 DIP-switch
DCD, DTR and DSR control



Use stored values



DCD and DSR always on,
DTR ignored (AT&C0&D0&S0)

S4 DIP-switch
Data compression control



Use stored values



Data compression disabled
(AT%C0)

S4 DIP-switch
Auto retrain control



Use stored values

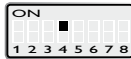

Auto retrain disabled (AT%E0)

S4 DIP-switch
Line mode setting



Use stored values

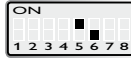

Reliable mode enable (AT%N2)



Buffer mode enabled (AT%N0)

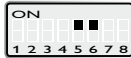

Direct Mode enabled (AT%N1)

S4 DIP-switch
Leased Line termination



Termination disabled



Termination of Receiver
in 4-wire mode

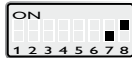

Termination of Transmitter / Receiver
in 2-wire mode and Transmitter in
4-wire mode

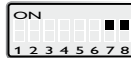

Termination of both Transmitter
and Receiver in 4-wire mode

S5 DIP-switch RS-422/485 termination



No termination



Termination of both T and R
in 2-wire connection



Termination of R in 4-wire
connection



Termination of both T and R
in 4-wire connection

Factory settings



S1



S3



S5

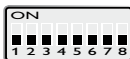

S2

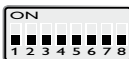

S4

V.23 2- / 4-wire HDX- / FDX-leased line settings

S1 DIP-switch

Selection of DTE speed



1200 bit/s

S1 DIP-switch

Selection of DTE-format



8E1, 8O1, 8O1
in command mode



8E2, 8O2, 8N2
in command mode



7E1, 7O1, 8N1, 8N1
in command mode



7E2, 7O2, 8N2, 8N2
in command mode

S2 DIP-switch

Leased line mode selection

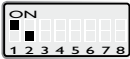

1200 bit/s leased line /mulidrop

S2 DIP-switch

Leased line 2/4-wire selection



2-wire leased line



4-wire leased line

S3 DIP-switch

V.23 line modulation



V.23 1200 HDX/FDX

S3 DIP-switch

Carrier active using RTS or incoming data



Incoming data



RTS controlled

S4 DIP-switch

Permanent carrier control



Disabled



Enabled

S4 DIP-switch
V.23 leased line termination*

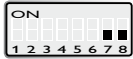

Termination disabled

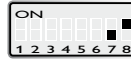

Termination of transmitter / receiver in 2-wire mode and Transmitter in 4-wire mode

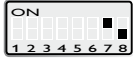

Termination of receiver in 4-wire mode

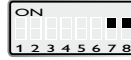

Termination of both transmitter / receiver in 4-wire mode

*The leased line should be terminated at the end points.

Termination recommendations of Leased lines and Dial-up connections

In some connections the communication line (Leased Line or PSTN) must be terminated. The table below shows the right way to activate the termination for different usages. As a standard, the receiver in multidrop systems at the end points shall be terminated.

S4 DIP-switch
Termination recommendations for TR-36



PSTN

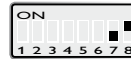

Multidrop
V23 2-wire – endunit

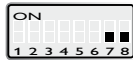

PSTN
Backup

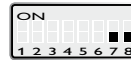

Multidrop
V23 2-wire – dropunit

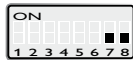

2-wire
Leased Line

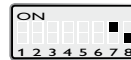

Multidrop
V23 4-wire – endunit

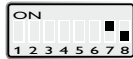

4-wire
Leased Line

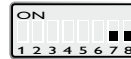

Multidrop
V23 4-wire – dropunit

RS-422/485 general advice

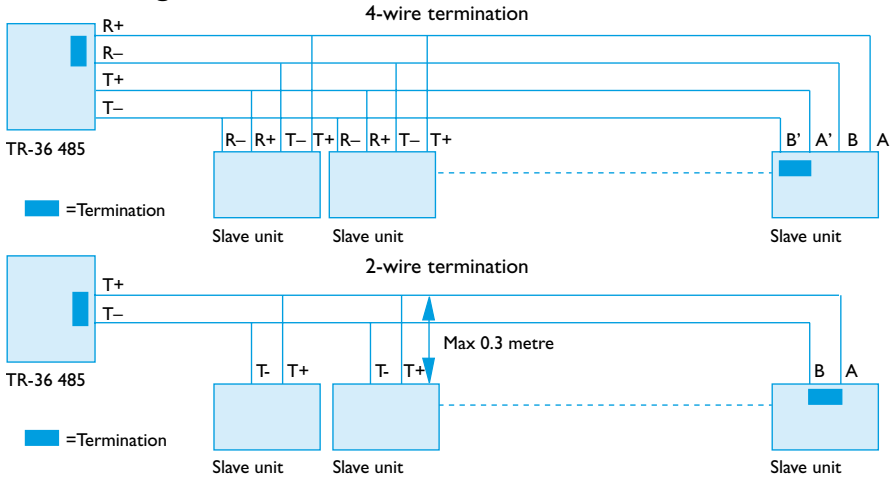

Termination recommendations

The RS-422/485 line must be terminated. In the TR-36, the termination is combined with fail-safe functionality. The termination is used to prevent undefined states when the bus is in tri-state condition.

- ⌘ Using 2-wire RS-485 both ends should be terminated.
- ⌘ Using 4-wire RS-485 both pairs shall be terminated at both ends.
- ⌘ Using 4-wire RS-422 it's only necessary to terminate the receivers.

RS-422/485 connection pins can be differently named. For some equipment brands the T+ corresponds to A, but other brands might use some other naming convention. If a unit does not work it can help to swap A and B.

Mounting /Removal

Before mounting or removing the unit:

This unit has one separate protective earthing terminal (marked with “symbol”⊕), while the unit is provided with two mains supply connectors. The grounding terminal of these mains supply connectors is a functional earthing point only.

Prevent access to hazardous voltages by disconnecting the unit from AC/DC mains supplies and all other electrical connections.

A protective earthing conductor should be connected to the protective earthing terminal and have a cross-sectional area of at least 1.5 mm².

Prevent damage to internal electronics from electrostatic discharges (ESD) by discharging your body to a grounding point (e.g. use of wrist strap).

Mounting

This unit should be horizontally mounted with screws in the holes located in the left and right hand brackets on the unit.

Connect the protective earthing conductor to the protective earthing terminal, before connection of any AC/DC mains supply or other electrical connections.

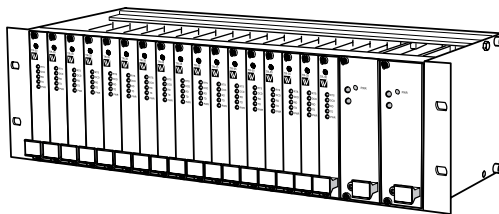

As this unit uses convection cooling, it is important to avoid obstructions that prevent normal vertical airflow through the unit. For this reason a clearance of 1U below and 2U above the unit is recommended. These clearance distances should be increased if heat from another unit is likely to cause an undesirable rise in temperature. Under no circumstances should the air temperature around the unit exceed 15 degrees C above the operating temperature of any modem installed in it. The unit should be installed in a cabinet that has suitable fans and filters so that good airflow is maintained without the ingress of dirt or dust.

Removal

Disconnect all AC/DC mains supplies and other electrical connections before the removal of protective earthing conductor from the protective earthing terminal.

Note:

- Always add modems from one end in the rack.
- To ensure proper galvanic connection between front panels, do not leave empty slots between modems.

Rear connections TR-36, RV-07 and Power Supply

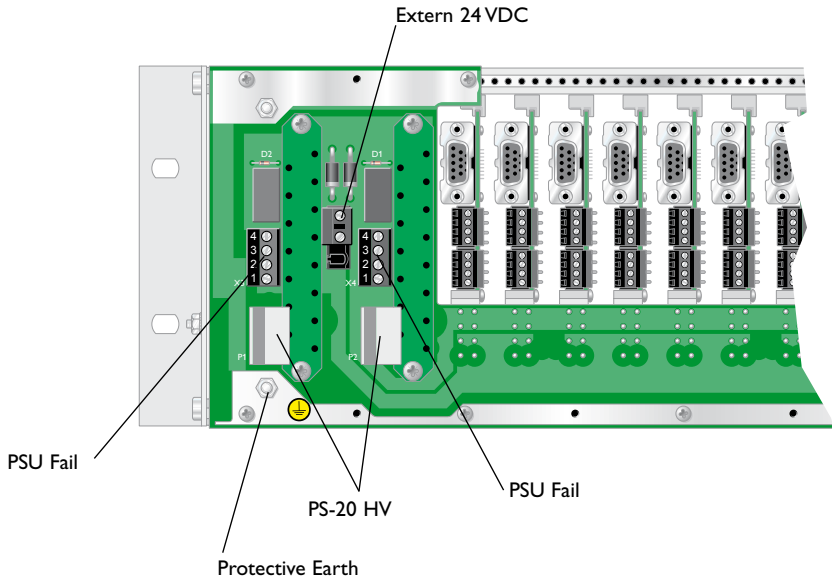

Windows configuration tool TD-Tool

The TD-Tool is a PC – application program with a graphical interface for easy configuration of the complex functions found on the enclosed CD or at the Westermo website. Please refer to TD-Tool for a complete description of the functionality of the Windows program.

AT-Commands

Please refer to the AT Commands Interface Guide found on the enclosed CD or at the Westermo website for a complete list of all available AT-commands and a detailed description of the serial AT-command interface.

Configuration

The TR-36 can be configured both from the local DTE interface and remotely over the PSTN network. Independently if the local or remote interface is used the configuration can be made with AT-commands or with a PC-based application configuration tool.

Basic configurations can also be made with DIP-switches locally.

Remote configuration

The TR-36 can be configured from a remote modem. To configure a TR-36 any GSM, ISDN or PSTN modem can be used.

The modem used to configure is referred as the “local modem”.

Please make sure that the remote TR-36 is connected to the PSTN network and is powered up.

- ⌘ Connect the local modem to it's media (ISDN, PSTN or GSM)
- ⌘ Connect the PC's com-port to the DTE interface of the local modem.
- ⌘ Connect the power supply.
- ⌘ Start a terminal emulation program (i.e. Windows Hyper-Terminal).
- ⌘ Configure the local modem data rate and word format.
- ⌘ Set up a connection to the remote TR-36 to be configured by using the normal dial command: `ATD<No><CR>`. When connected send the remote escape sequence `<++++>`. The called remote TR-36 will acknowledge by requesting the remote password. Enter the correct password (default: no password, just return). Next; configure the remote TR-36 using AT-commands. The password for remote configuration is defined with `AT*WRCP` – Remote configuration password.
- ⌘ Configure the parameter on the remote TR-36 from your terminal program and save the settings with `AT&W`.
- ⌘ Hang up the connection using the `ATH` command.

Application example

☒ TR-36 connected to TR-36 with DTR signal call



Configure the units	
AT&F	Set the unit to factory default.
AT&W	Store default settings.
Set up the connection – The dialling modem	
AT&Z0="nnn"	Store the number of the remote modem in the dialling TR-36.
AT&S0	Set DSR signal always high (if this signal is used to trig the DTR).
AT&B1	Activates automatic DTR dialling if DTR switches from low (OFF) to high (ON).
AT&W	Save settings.
Switch DTR from OFF to ON	The modem will now dial the phone number stored in the first location of the telephone number table (AT&Z0=<nnn>)
Set up the connection – The answering modem	
ATA	Enter the answer command when RING comes from the network or set up ATS0=1 to auto answer on 1 RING signal (or more than 1).

NOTE: If no valid DTR signal can be provided by external application, the modems DSR signal can be used to trig the transmission. Connect the DSR signal via a relay, or other potential free contact, to the DTR signal. A 10 kohm pull down resistor should also be connected between the DTR and a signal that is always low e.g. the DCD.

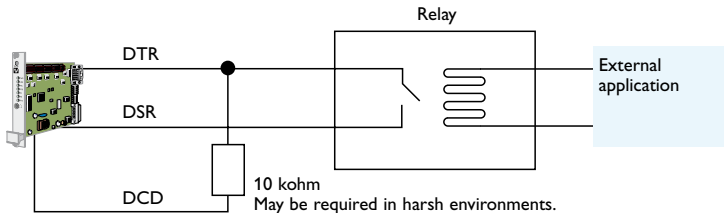

⌘ TR-36 – Secure Call-back

The TR-36 is connected to a PLC which one want to restrict access to. The TR-36 can support access control through the Secure Callback function. In this example password and callback to a predefined number is chosen. The modem in the calling end is here chosen to be a PSTN modem, but can be any of the PSTN, ISDN or GSM modem from Westermo product range.

The DTE serial speed between the PLC – TR-36 and TDW-33 – PC is assumed to be 9600 8N1 but can be chosen to fit the actual system requirement.

Configure the TR-36	
AT&F	Set the unit to factory default
AT+IPR=9600	DTE baudrate 9600
AT+ICF=3,4	Character framing 8 data, 1 stop, parity none
ATS0=1	Auto answer after first ring
ATQ1E0&C1&K0&A1	Suitable for PLC communication
AT&W	Save settings
AT*WCB=4	Callback enabled, Password in one or more positions in *wcbpwdx (x= 1,2 or 3), call-back to number in wcbtab (*wcbpwd1 corresponds to *wcbtab1...)
AT*WCBTAB=1,"+4670428000","n3Y9kA6otYZu8"	Define callback number and password in position 1. When the password is entered number +4670428000 will be called.
AT*WCBTIME=10	Define delay time between hangup an callback. The TR-36 will wait 10 s after hangup to callback to allow the analogue modem to hangup.
Configure the TDW-33	
AT&F	Set the unit to factory default
AT+IPR=9600	DTE baudrate 9600
AT+ICF=3,4	Character framing 8 data, 1 stop, parity none
ATS0=1	Auto answer after first ring
AT&W	Store default settings

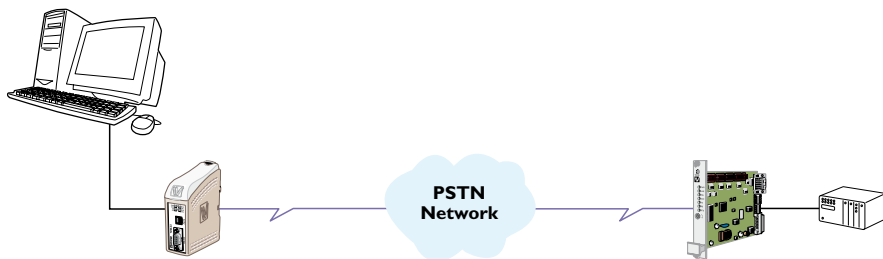

Set up the connection		
The dialling modem TDW-33	The answering modem TR-36	Comment
ATD0705123456	TR-36 answers the call and requests to TDW-33	Dial the number to TR-36
CONNECT 9600 Password: <i>n3Y9kA6otYZu8</i>	TR-36 verifies the password to the passwords stored and if true compare disconnects.	Operator/system at TDW-33 enters Password <i>n3Y9kA6otYZu8</i>
NO CARRIER	Wait 10 s	The connection is broken and TR-36 waits the programmed 10 s for TDW-33 to disconnect
	TR-36 dials <i>+4670428000</i>	The number programmed corresponding to the password is dialled, preferable it's the number to the TDW-33
CONNECT 9600	CONNECT 9600	Connection is established between the PC at TDW-33 and the PLC at TR-36

☒ Silent answering on predefined numbers TR-36

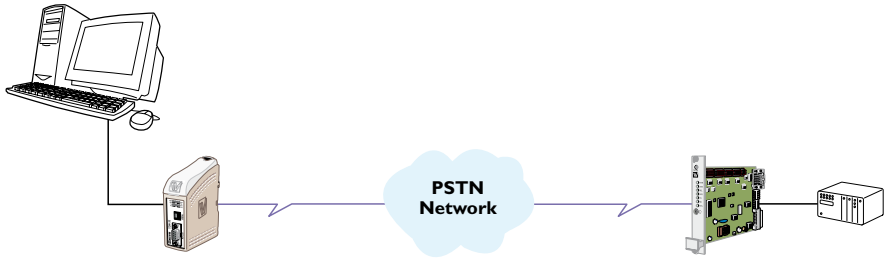

The TR-36 is connected to Power meter which is remotely monitored and the TR-36 shares the PSTN line with normal telephones which is preferred not to give a Ring signal when the meter is read.

The TR-36 is setup to answer calls on the Caller ID received, the valid numbers to answer is programmed into the TR-36. There exists a number of standards for sending Caller ID please check which standard is used by your operator, the TR-36 supports the major implementations. In this example the DTMF Caller ID version is used. Note some implementations doesn't give the possibility to make a silent answer since the Caller ID is sent between first and second ring signal.

On the originating side any type of modem able to call a PSTN number can be used.

Configure the TR-36	
AT&F	Set the unit to factory default
AT+IPR=9600	DTE baudrate 9600
AT+ICF=3,4	Character framing 8 data, 1 stop, parity none
ATS0=0	No auto answer on Ring signals
ATQ1E0&C1&K0&A1	Suitable for PLC communication
AT&W	Save settings
AT*WACCTAB=1,"016428000" AT*WACCTAB=2,"016480250"	Set the valid A-numbers for automatic answering
AT*WCID=3,3	Set Caller ID to A-number answer with DTMF coded numbers

⌘ Frequently used settings for PLC-systems



Most PLC-systems and other industrial applications where modems are used require the same changes to the standard settings.

The most commonly encountered problems concern speed, parity and control signals from the connected equipment.

Speed and parity are changed with the switches under the cover in block S1. If this action does not solve the problem the modem's answering codes and possible echoing of commands might be the source of the difficulty.

Below follows a list of commands that might resolve the problems. The commands may of course be placed on one single command line if desired.

Configure the TR-36 connected to the PLC	
AT&F	Set the unit to factory default
ATV0	Gives the answering codes in short format. (digits)
ATQ1	No result codes are sent on the RS-232/V.24 connection.
ATE0	Commands that are sent from the terminal/computer etc. are not echoed back to the RS-232/V.24 connection.
AT&C1	DCD will follow the carrier on the line.
AT&K0	No handshaking.
AT&A1	Character abort option on.
AT&W	Save settings

Note: S3:5 may be used for this purpose.

⌘ Leased line connection using 2- or 4-wire



Leased line connections can be set up using either 2- or 4-wire. When renting a 4-wire line from a telephone company one pair of cables for transmission and one pair for reception are usually provided.

The maximum transmission distance depends on the attenuation of the line. The maximum value is theoretically 30 dBm. To have a good error rate it is recommended to keep the attenuation under 25 dB. When renting lines from a telephone company a longer transmission distance is normally possible as the signals are probably transmitted over PCM-lines, i.e. fibre optic or other media with low attenuation.

To set the modem for leased line applications use the dip switches.

Configure the units	
S2:1, 2 ON S2:2 ON	Leased line calling Leased line answering
S2:5 OFF	Leased line 2-wire
S2:5 ON	Leased line 4-wire
S1	Sets speed and parity for the RS-232 port.
S3	Decides line-speed. Must be set in direct mode applications.

To make switch setting active the power must be cycled OFF -> ON.

Resistance, attunation and distance for different wires

Tele Cable	Area	Resistance for double cable	Attunation	Recommended Max distance (25 dB)	Max Distance (30 dB)
∅ 0,5 mm*	≈ 0,2 mm ²	175 Ω/km	1,1 dB/km	23 km	27 km
∅ 0,6 mm*	≈ 0,3 mm ²	123 Ω/km	0,9 dB/km	28 km	33 km
∅ 0,7 mm*	≈ 0,4 mm ²	93 Ω/km	0,8 dB/km	31 km	38 km
∅ 0,8 mm	≈ 0,5 mm ²	73 Ω/km	0,7 dB/km	36 km	43 km
∅ 0,9 mm	≈ 0,64 mm ²	59 Ω/km	0,6 dB/km	42 km	50 km

* Frequently used in the local network

⌘ TR-36 485 – two wire half duplex

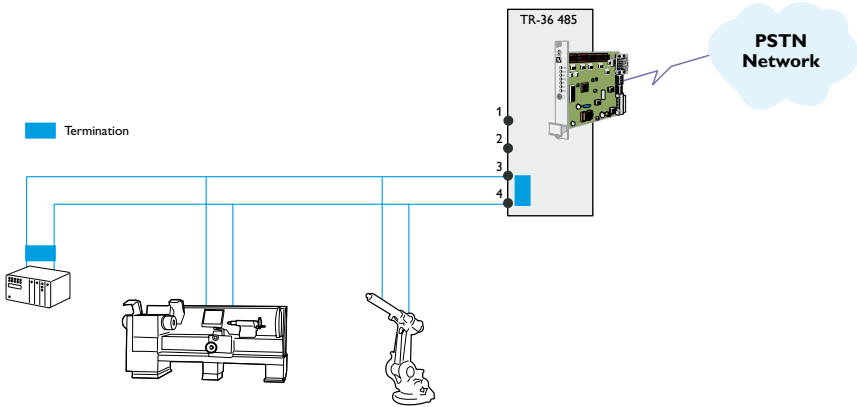

In this application the TR-36 is set to communicate with a number of units with RS-485 interface.

The communication is 2 wire half duplex at 38.4 kbit/s, 8 data, parity even and 1 stop bit.

Configure the TR-36 485	
AT&F	Set the unit to factory default
AT&W	Store default settings
S2:3 ON	RS-422/485 enable RS-232 disable
S2:4 OFF	Select 2-wire RS-485
S1:4 ON	38.4 kbit/s
S1:7 ON	8 data bits even parity 1 stop bit
S4:8 ON	Termination / Failsafe active

To make switch setting active the power must be cycled OFF ≥ ON.



Westermo Teleindustri AB • SE-640 40 Stora Sundby, Sweden
Phone +46 16 42 80 00 Fax +46 16 42 80 01
E-mail: info@westermo.se
Westermo Web site: www.westermo.com

Subsidiaries

Westermo Data Communications AB
SE-724 81 Västerås
Phone: +46 (0)16 42 80 00 • Fax: +46 (0)21 35 18 50
E-mail: info.sverige@westermo.se

Westermo OnTime AS
Gladsvei 20 0489 Oslo, Norway
Phone +47 22 09 03 03 • Fax +47 22 09 03 10
E-mail: contact@ontimenet.com

Westermo Data Communications Ltd
Talisman Business Centre • Duncan Road
Park Gate, Southampton • SO31 7GA
Phone: +44(0)1489 580-585 • Fax: +44(0)1489 580586
E-Mail: sales@westermo.co.uk

Westermo Data Communications GmbH
Goethestraße 67, 68753 Waghäusel
Tel.: +49(0)7254-95400-0 • Fax: +49(0)7254-95400-9
E-Mail: info@westermo.de

Westermo Data Communications S.A.R.L.
9 Chemin de Chilly 91160 CHAMPLAN
Tél : +33 1 69 10 21 00 • Fax : +33 1 69 10 21 01
E-mail : infos@westermo.fr

Westermo Data Communications Pte Ltd
2 Soon Wing Road #08-05
Soon Wing Industrial Building
Singapore 347893
Phone +65 6743 9801 • Fax +65 6745 0670
E-mail: earnestphua@westermo.com.sg

Westermo Teleindustri AB have distributors in several countries, contact us for further information.