

Reference Guide

6193-5201

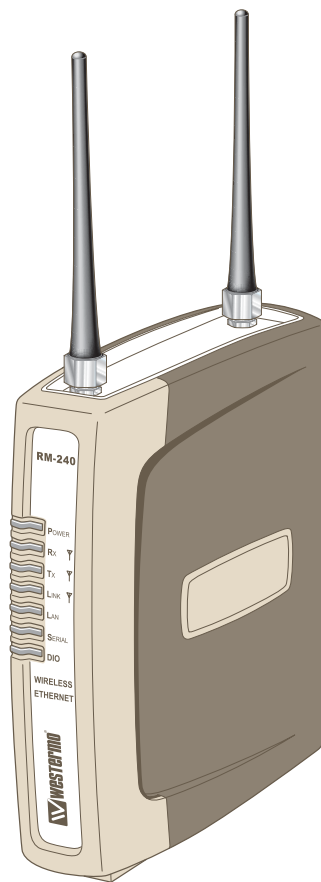

RM-240



**Wireless Ethernet
Radio Modem**

www.westermo.com

Thank you for your selection of the RM-240 Wireless Ethernet Modem.
We trust it will give you many years of valuable service.

ATTENTION!

Incorrect termination of supply wires may cause internal damage and will void warranty.

To ensure your RM-240 enjoys a long life,

double check ALL your connections with the users manual before turning the power on.

Caution!

For continued protection against risk of fire, replace the internal module fuse only with the same type and rating.

CAUTION:

To comply with FCC RF Exposure requirements in section 1.1310 of the FCC Rules, antennas used with this device must be installed to provide a separation distance of at least 20 cm from all persons to satisfy RF exposure compliance.

DO NOT:

- ⚠ operate the transmitter when someone is within 20 cm of the antenna
- ⚠ operate the transmitter unless all RF connectors are secure and any open connectors are properly terminated.
- ⚠ operate the equipment near electrical blasting caps or in an explosive atmosphere

All equipment must be properly grounded for safe operations.
All equipment should be serviced only by a qualified technician.

Important Notice

WESTERMO products are designed to be used in industrial environments, by experienced industrial engineering personnel with adequate knowledge of safety design considerations.

WESTERMO radio products are used on unprotected license-free radio bands with radio noise and interference. The products are designed to operate in the presence of noise and interference, however in an extreme case, radio noise and interference could cause product operation delays or operation failure. Like all industrial electronic products, WESTERMO products can fail in a variety of modes due to misuse, age, or malfunction. We recommend that users and designers design systems using design techniques intended to prevent personal injury or damage during product operation, and provide failure tolerant systems to prevent personal injury or damage in the event of product failure. Designers must warn users of the equipment or systems if adequate protection against failure has not been included in the system design. Designers must include this Important Notice in operating procedures and system manuals.

These products should not be used in non-industrial applications, or life-support systems, without consulting WESTERMO Technologies first.

1. A radio license is not required in some countries, provided the module is installed using the aerial and equipment configuration described in the *RM-240 Installation Guide*. Check with your local distributor for further information on regulations.
2. Operation is authorized by the radio frequency regulatory authority in your country on a non-protection basis. Although all care is taken in the design of these units, there is no responsibility taken for sources of external interference. Systems should be designed to be tolerant of these operational delays.
3. To avoid the risk of electrocution, the aerial, aerial cable, serial cables and all terminals of the RM-240 module should be electrically protected. To provide maximum surge and lightning protection, the module should be connected to a suitable earth and the aerial, aerial cable, serial cables and the module should be installed as recommended in the *Installation Guide*.
4. To avoid accidents during maintenance or adjustment of remotely controlled equipment, all equipment should be first disconnected from the RM-240 module during these adjustments. Equipment should carry clear markings to indicate remote or automatic operation. E.g. "This equipment is remotely controlled and may start without warning. Isolate at the switchboard before attempting adjustments."
5. The RM-240 module is not suitable for use in explosive environments without additional protection.

The RM-240 Industrial WiFi Wireless Ethernet module provides wireless connections between Ethernet devices or Ethernet wired networks (LAN's). It complies with the IEEE 802.11b standard. The RM-240 has an internal 2.4GHz direct sequence spread spectrum (DSSS) wireless transceiver, which can be used without a radio license in most countries. Users can select one of 11 x 5 MHz wide channels, with the first channel centred at 2.412 GHz.

Note that regulations in North America and part of Europe permit all 11 channels to be used in these countries. Please check with your WESTERMO representative for the permitted channel usage in your country.

The RM-240 unit also provides two serial connections as well as the Ethernet connections. It is possible to use all three data connections concurrently, allowing the RM-240 to act as a Device Server. Wireless connections can be made between serial devices and Ethernet devices, however appropriate driver applications are required in the host devices to handle the different data format. The RM-240 does provide connection functionality between serial "Modbus RTU" devices and Ethernet "Modbus TCP" devices.

The RM-240 is available in two models with different RF power:

RM-240-100 100mW of RF power

RM-240-300 300mW of RF power

Note that European regulations do not permit more than 100mW of RF power to be used. In USA, Canada and Australia, up to 1W of RF power may be generated. In other countries, please check with your WESTERMO representative.

The RM-240 has a standard RJ45 Ethernet connection which will operate at up to 100Mbit/sec. The module will transmit the Ethernet messages on the wireless band at rates between 1 and 11 Mbit/sec.

1.1 Network Topology

The RM-240 is an Ethernet device, and must be configured as part of an Ethernet network. Each RM-240 must be configured as:

- an “Access Point” or a “Client”, and
- a “Bridge” or a “Router”.

You can also connect to the RM-240 via a RS-232 or RS-485 serial port using PPP

(point-to-point) protocol. PPP allows the RM-240 to connect serial communications into the Ethernet network.

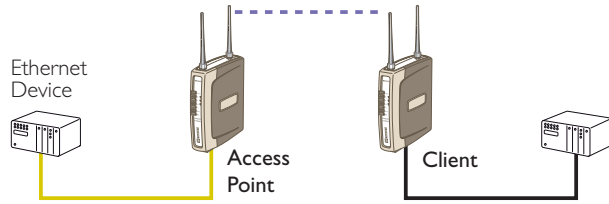

Access Point vs Client

The Access Point unit acts as the “wireless master” unit. The Access Point sets up the wireless links to the Client units, and controls the wireless communications. The first diagram shows two Ethernet devices being linked. One RM-240 is configured as an Access Point and one as a Client – in this example it doesn’t matter which unit is the Access Point.

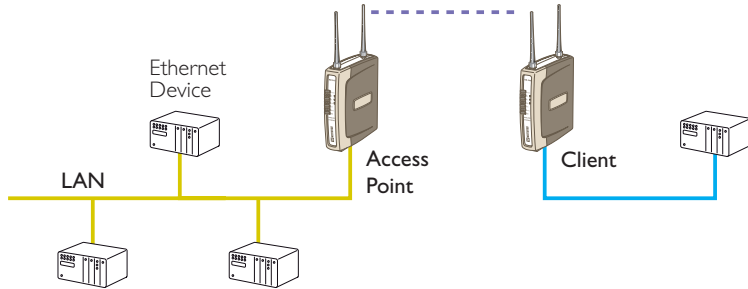

The second diagram shows an existing LAN being extended using RM-240’s. In this example, the Access Point should be configured at the LAN end – although the wireless link will still work if the Client is at the LAN end.

An Access Point can connect to multiple Clients. In this case, the Access Point should be the “central” unit.

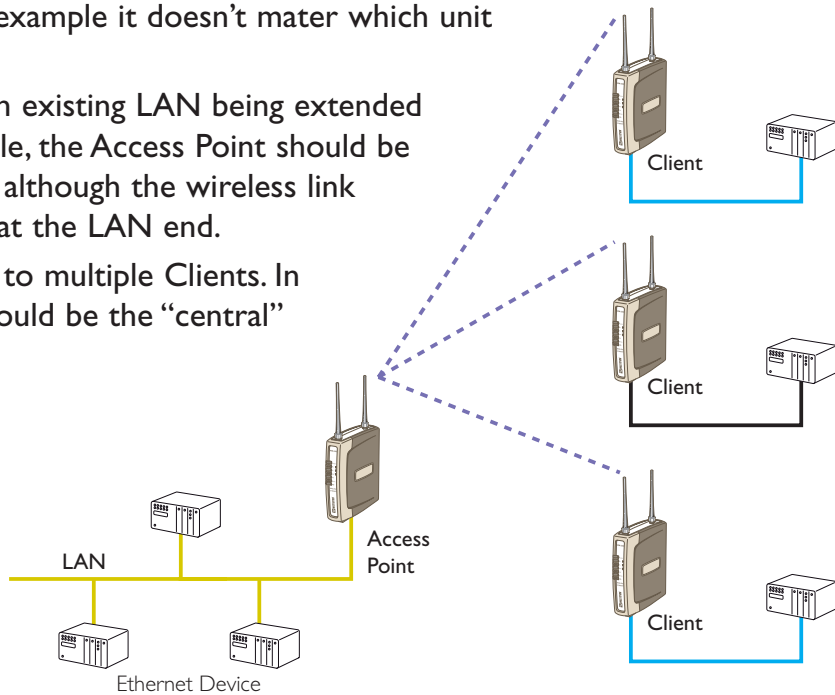

An Access Point could be used as a “Repeater” unit to connect two RM-240 Clients which do not have direct reliable radio paths.

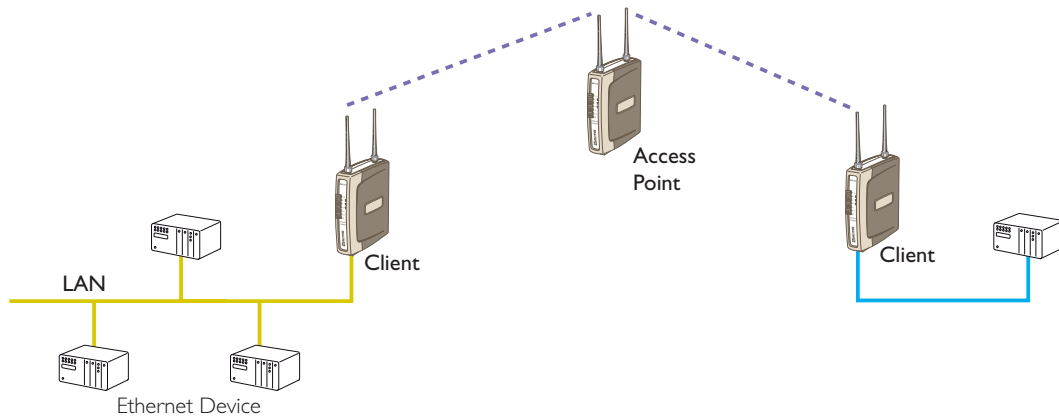

Multiple Access Points can be set-up in a “mesh” network to provide multiple repeaters.

Bridge vs Router

Each RM-240 is configured with an IP address for the Ethernet side, and another for the wireless side.

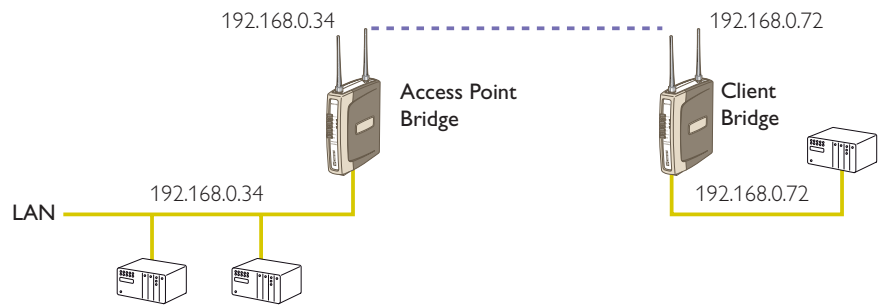

A **Bridge** connects devices within the same

Ethernet network – for example, extending an existing Ethernet LAN. For a Bridge, the IP address for the wireless side is the same as the Ethernet side.

A **Router** connects devices on different LAN’s. The IP addresses for the Ethernet and wireless sides are different.

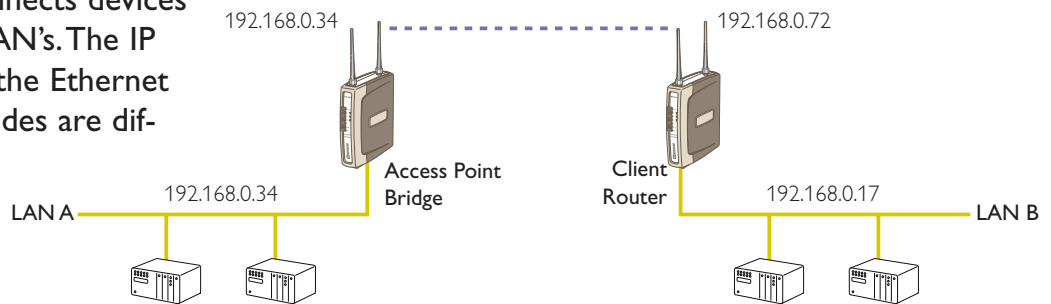

In the above example, the wireless link is part of LAN A, with the Client unit acting as a Router between LAN A and LAN B. Alternately, the Access Point could be configured as a Router – the wireless link is then part of LAN B.

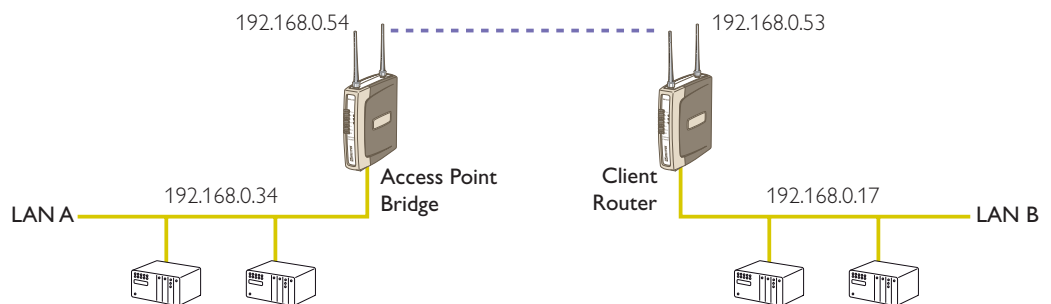

If more than two routers are required within the same radio network, then routing rules may need to be configured (refer section “3.11 Routing Rules” for further details). There is no limit to the number of Bridges in the same network – although there is a limit of 255 Client units linked to any one Access Point.

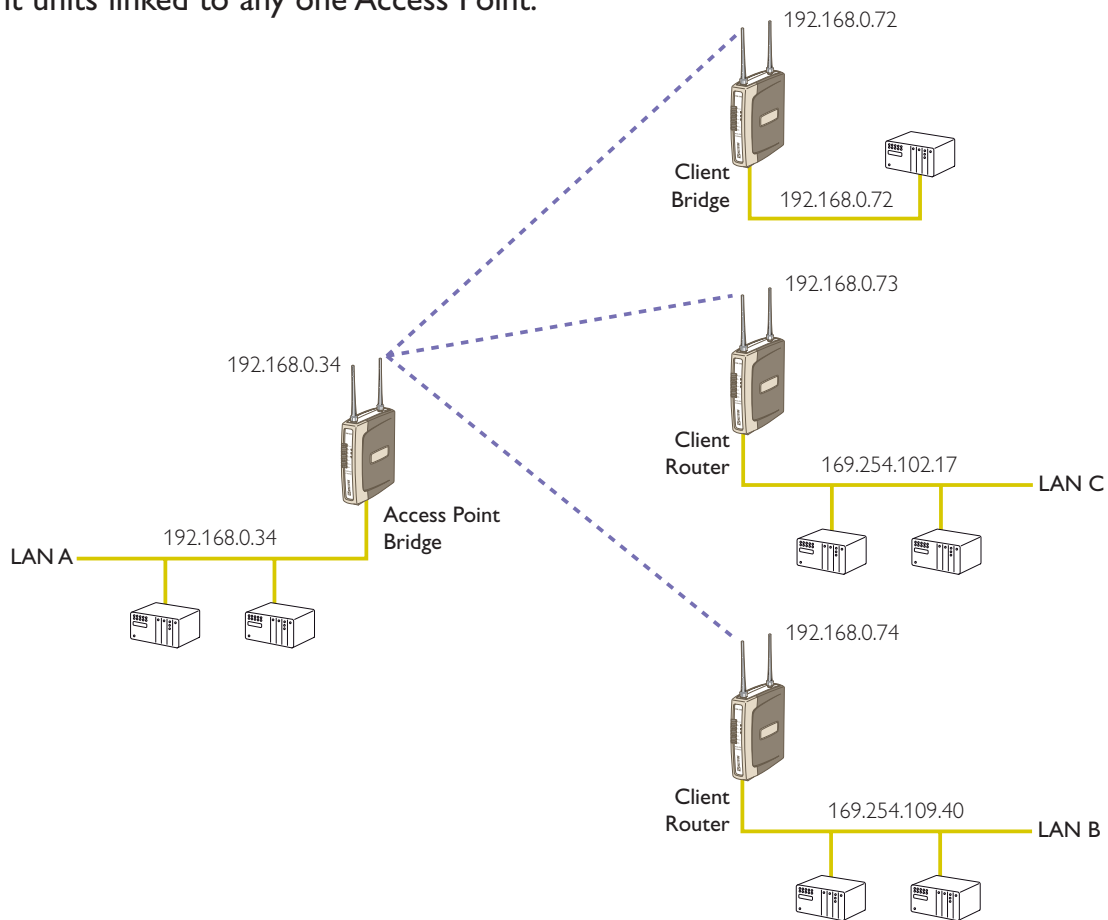

1.2 Getting Started Quickly

Most applications for the RM-240 require little configuration. The RM-240 has many sophisticated features, however if you don't require these features, this section will allow you to configure the units quickly.

First, read Section 2, “Installation”. The RM-240 requires an antenna and a power supply.

- ⌘ Power the RM-240 and make an Ethernet connection to your PC (for further information on how to do this, refer to section 3.3)
- ⌘ Set the RM-240 address settings as per section 3.4
- ⌘ Save the configuration – the RM-240 is now ready to use.

Before installing the RM-240, bench test the system. It is a lot easier to locate problems when the equipment is all together.

There are other configuration setting which may or may not improve the operation of the system. For detail on these settings, refer to section 3.

2.1 General

The RM-240 module is suitable for DIN-rail mounting. Terminals will accept wires up to 2.5 sqmm (12 gauge) in size.

All connections to the module must be SELV. Normal 110-240V mains supply should not be connected to any terminal of the RM-240 module. Refer to Section 2.3 **Power Supply**.

Before installing a new system, it is preferable to bench test the complete system. Configuration problems are easier to recognize when the system units are adjacent. Following installation, the most common problem is poor communications caused by incorrectly installed antennas, or radio interference on the same channel, or the radio path being inadequate. If the radio path is a problem (ie path too long, or obstructions in the way), then higher performance antennas or a higher mounting point for the antenna may rectify the problem. Alternately, use an intermediate RM-240 Module as a repeater.

Each RM-240 module should be effectively earthed via the “GND” terminal on the RM-240 module – this is to ensure that the surge protection circuits inside the RM-240 module are effective.

2.2 Antenna Installation

The RM-240 module will operate reliably over large distances. The distance which may be reliably achieved will vary with each application – depending on the type and location of antennas, the degree of radio interference, and obstructions (such as buildings or trees) to the radio path.

The maximum range achievable depends on the regulated RF power permitted in your country, and whether you use separate transmit and receive antennas. With a single antenna, 5 km (3 miles) can be achieved in USA, Canada and Australia (4W ERP) and 1km in Europe (100mW ERP). With separate transmit and receive antennas, more than 10km (6 miles) can be achieved in USA, Canada and Australia and more than 5 km in Europe.

To achieve the maximum transmission distance, the antennas should be raised above intermediate obstructions so the radio path is true “line of sight”. The modules will operate reliably with some obstruction of the radio path, although the reliable distance will be reduced. Obstructions which are close to either antenna will have more of a blocking affect than obstructions in the middle of the radio path. The RM-240 modules provide a diagnostic feature which displays the radio signal strength of transmissions (refer Diagnostics section).

Line-of-sight paths are only necessary to obtain the maximum range. Obstructions will reduce the range, however may not prevent a reliable path. A larger amount of obstruction can be tolerated for shorter distances. For short distances, it is possible to mount the antennas inside buildings. An obstructed path requires testing to determine if the path will be reliable – refer the section 6 of this manual.

Where it is not possible to achieve reliable communications between two RM-240 modules, then a third RM-240 module may be used to receive the message and re-transmit it. This module is referred to as a repeater. This module may also have a host device connected to it.

The RM-240 unit has two antenna connections at the top of the module, allowing two antennas to be fitted to the unit. The left connector (looking at the front) labeled “RX” is connected only to the internal wireless receiver. The right connector labeled TX/RX is connected to both the transmitter and receiver.

Note: when only one antenna is used, it must be connected to the right TX/RX connector.

Plant and factory installations

Most installations in industrial plants and factories use a single omni-directional antennas. Installations can suffer from “multi-path fading” effects where multiple reflected radio signals adversely affect the signal strength. This can be checked by moving the antenna a short distance (10 cm or 4 inches) – if the signal increases significantly then there are multi-path effects.

In a “static” installation, where the radio path is not changing, moving an antenna to the position of maximum signal solves this problem. However where the radio path changes because the RM-240 is mounted on moving equipment, or if there is moving equipment in the area, then the solution is to use two antennas. Because the two connectors are separated, the RF signal at each connector will be different in the presence of multi-path fading. The RM-240 unit will automatically select the higher RF signal.

Note that directional antennas are not normally used in plant and factory installations.

Line-of-sight installations

In longer line-of-sight installations, the range may be increased by using a high gain antenna on the TX/RX connector. However the gain should not cause the effective radiated power (ERP) to exceed the permitted value. A second higher gain antenna can be connected to the RX connector without affecting ERP – this will increase the operating range provided the background noise in the area is low.

Antennas

Antennas can be either connected directly to the module connectors or connected via 50 ohm coaxial cable (eg RG58 Cellfoil or RG213) terminated with a male SMA coaxial connector. The higher the antenna is mounted, the greater the transmission range will be, however as the length of coaxial cable increases so do cable losses.

The net gain of an antenna/cable configuration is the gain of the antenna (in dBi) less the loss in the coaxial cable (in dB). The maximum net gain of the antenna/cable configuration connected to the TX/RX connector is 0dB in Europe (100mW ERP). In USA, Canada and Australia (4W ERP), the maximum gain is 12dB for the RM-240-300 or 16dB for the RM-240-100. There is no gain restriction for antennas connected to the RX connector.

The gains and losses of typical antennas are

Antenna	Gain (dBi)
Dipole	2
Collinear	5 or 8
Directional	10 – 28
Cable type	Loss (dB per 10 m / 30 ft)
RG58 Cellfoil	-6
RG213	-5
LDF4-50	-1.5

The net gain of the antenna/cable configuration is determined by adding the antenna gain and the cable loss. For example, a 5dBi antenna with 10 metres of Cellfoil has a net gain of -1 dB (5dB – 6dB).

Installation tips

Connections between the antenna and coaxial cable should be carefully taped to prevent ingress of moisture. Moisture ingress in the coaxial cable is a common cause for problems with radio systems, as it greatly increases the radio losses. We recommend that the connection be taped, firstly with a layer of PVC Tape, then with a vulcanizing tape such as “3M 23 tape”, and finally with another layer of PVC UV Stabilized insulating tape. The first layer of tape allows the joint to be easily inspected when trouble shooting as the vulcanizing seal can be easily removed.

Where antennas are mounted on elevated masts, the masts should be effectively earthed to avoid lightning surges. For high lightning risk areas, surge suppression devices between the module and the antenna are recommended. If the antenna is not already shielded from lightning strike by an adjacent earthed structure, a lightning rod may be installed above the antenna to provide shielding.

2.2.1 Dipole and Collinear antennas.

A dipole or collinear antenna transmits the same amount of radio power in all directions – as such that are easy to install and use. The dipole antenna with integral 5 metres (15 feet) cable does not require any additional coaxial cable, however a cable must be used with the collinear antennas.

Collinear and dipole antennas should be mounted vertically, preferably 30 cm (1 foot) away from a wall or mast to obtain maximum range.

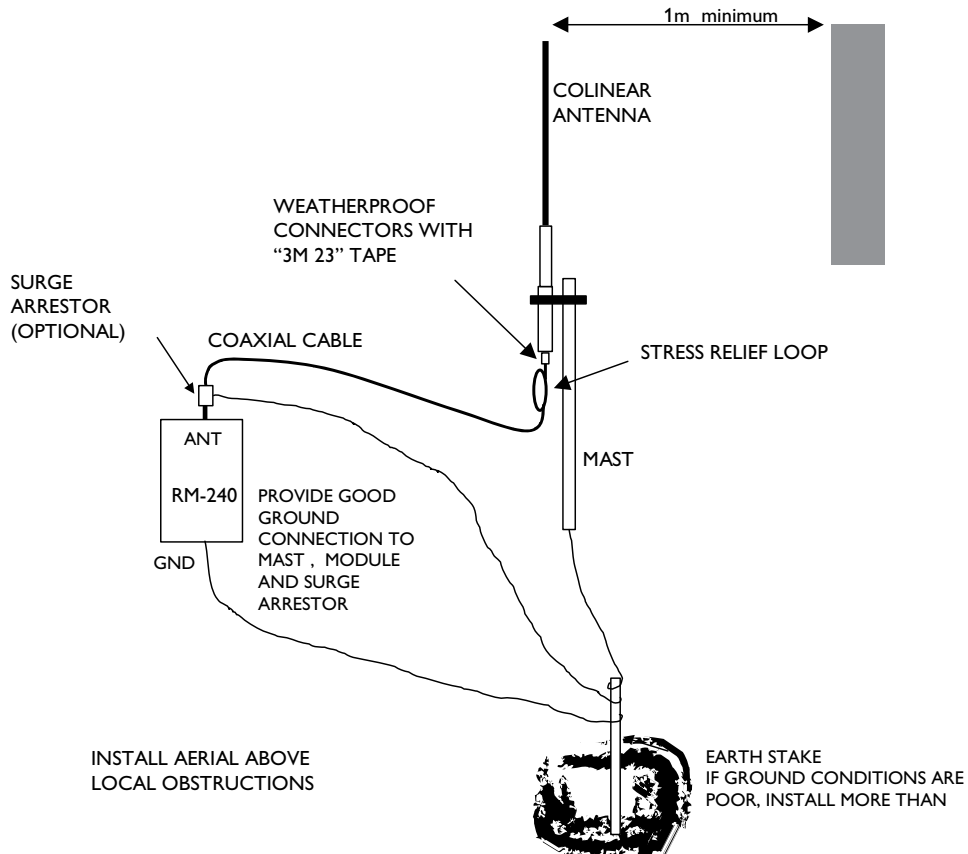

2.2.2 Directional antennas.

Directional antennas can be

- ⌘ a Yagi antenna with a main beam and orthogonal elements, or
- ⌘ a directional radome, which is cylindrical in shape, or
- ⌘ a parabolic antenna.

A directional antenna provides high gain in the forward direction, but lower gain in other directions. This may be used to compensate for coaxial cable loss for installations with marginal radio path.

Yagi antennas should be installed with the main beam horizontal, pointing in the forward direction. If the Yagi is transmitting to a vertically mounted omni-directional antenna, then the Yagi elements should be vertical. If the Yagi is transmitting to another Yagi, then the elements at each end of the wireless link need to be in the same plane (horizontal or vertical).

Directional radomes should be installed with the central beam horizontal and must be pointed exactly in the direction of transmission to benefit from the gain of the antenna. Parabolic antennas should be mounted as per the manufacturer's instructions, with the parabolic grid at the "back" and the radiating element pointing in the direction of the transmission.

Ensure that the antenna mounting bracket is well connected to "ground/earth".

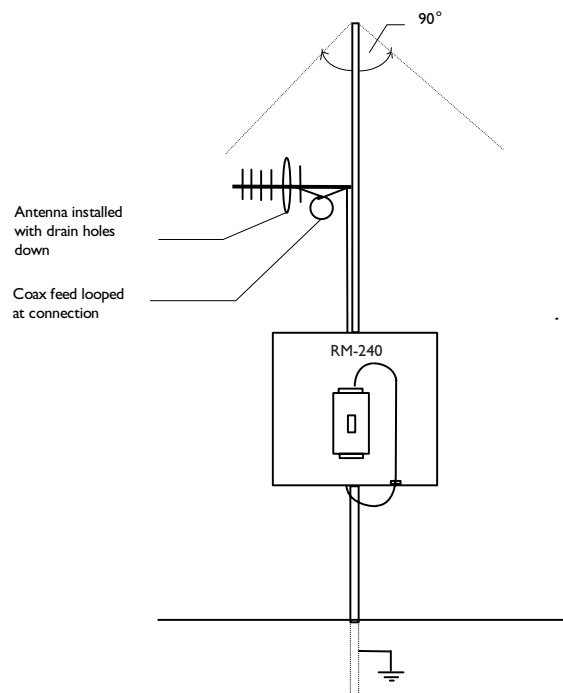

2.3 Power Supply

The RM-240 module can be powered from a 9 – 30VDC power supply. The power supply should be rated at 1 Amp. The positive side of the supply must not be connected to earth. The supply negative is connected to the unit case internally. The DC supply may be a floating supply or negatively grounded.

The power requirements of the RM-240 unit is 240mA @ 12V or 150mA @ 24VDC. This is inclusive of radio and Ethernet ports active, & serial port plugged in.

Transmission current is nominally 350mA at 12V (200mA at 24V) for the 100mW RF unit, and 500mA at 12V (350mA at 24V) for the 300mW RF unit.

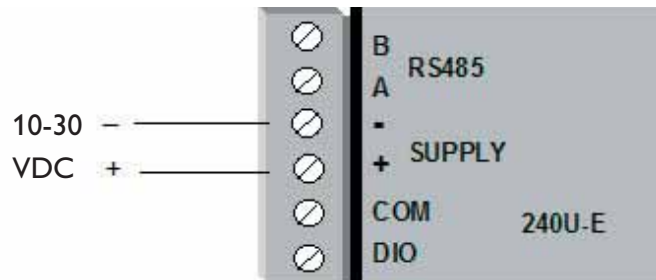

A Ground Terminal is provided on the back of the module. This Terminal should be connected to the Main Ground point of the installation in order to provide efficient surge protection for the module (refer to the Installation Diagram)

2.4 Serial Connections

2.4.1 RS-232 Serial Port

The serial port is a 9 pin DB9 female and provides for connection to a host device as well as a PC terminal for configuration, field testing and for factory testing. Communication is via standard RS232 signals.

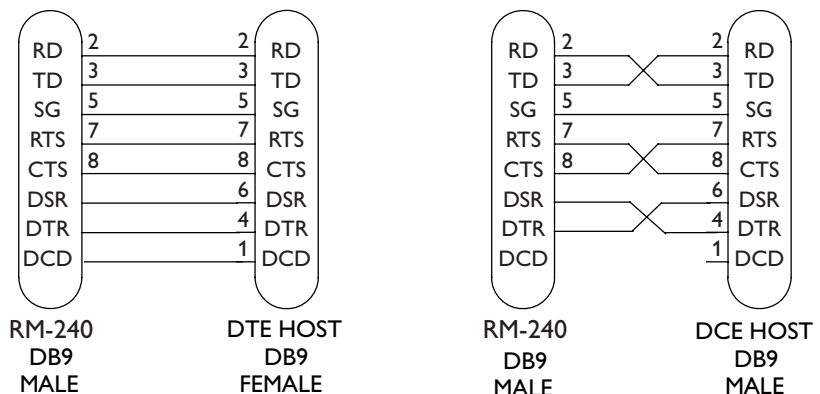

The RM-240 is configured as DCE equipment with the pinouts detailed below.

Hardware handshaking using the CTS/RTS lines is provided. The CTS/RTS lines may be used to reflect the status of the local unit's input buffer, or may be configured to reflect the status of CTS/RTS lines at the remote site. The RM-240 does not support XON/XOFF.

Example cable drawings for connection to a DTE host (a PC) or another DCE hosts (or modem) are detailed above.

DB9 Connector Pinouts

Pin	Name	Direction	Function
1	DCD	Out	Data carrier detect –
2	RD	Out	Transmit Data – Serial Data Output
3	TD	In	Receive Data – Serial Data Input
4	DTR	In	Data Terminal Ready –
5	SG		Signal Ground
6	DSR	Out	Data Set Ready – always high when unit is powered on.
7	RTS	In	Request to Send –
8	CTS	Out	Clear to send –
9	RI		Ring indicator –

2.4.2 RS-485 Serial Port

The RS-485 port provides for communication between the RM-240 unit and its host device using a multi-drop cable. Up to 32 devices may be connected in each multi-drop network. As the RS-485 communication medium is shared, only one of the units on the RS-485 cable may send data at any one time. Thus communication protocols based on the RS-485 standard require some type of arbitration.

RS-485 is a balanced, differential standard but it is recommended that shielded, twisted pair cable be used to interconnect modules to reduce potential RFI. It is important to maintain the polarity of the two RS-485 wires. An RS-485 network should be wired as indicated in the diagram below and terminated at each end of the network with a 120 ohm resistor. On-board 120 ohm resistors are provided and may be engaged by operating the single DIP switch in the end plate next to the RS-485 terminals. The DIP switch should be in the “1” or “on” position to connect the resistor. If the module is not at one end of the RS-485 cable, the switch should be off.

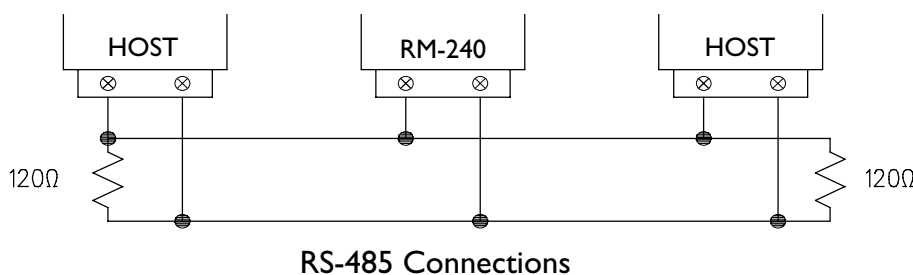

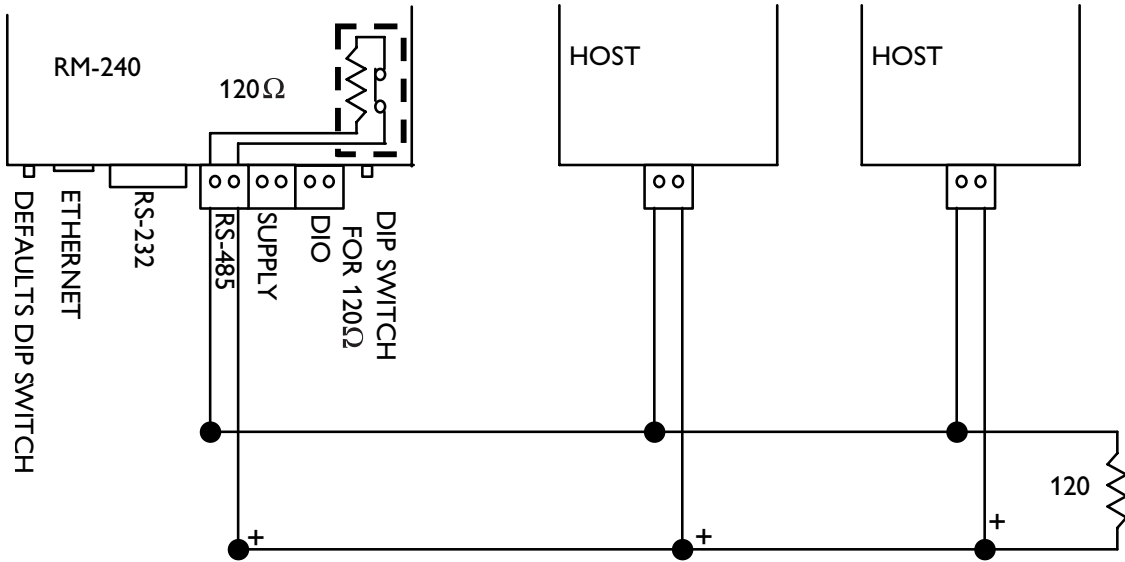

RS-485 connection using terminating resistor

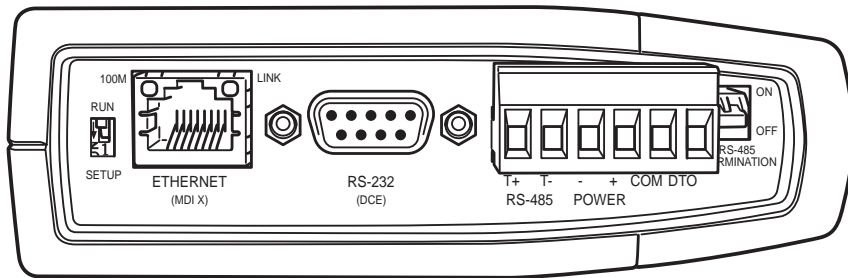

2.5 Discrete (Digital) Input/Output

The RM-240 has one on-board discrete/digital I/O channel. This channel can act as either a discrete input or discrete output. It can be monitored, or set remotely, or alternatively used to output a communications alarm status.

If used as an “input”, the I/O channel is suitable for voltage free contacts (such as mechanical switches) or NPN transistor devices (such as electronic proximity switches). PNP transistor devices are not suitable. Contact wetting current of approximately 5mA is provided to maintain reliable operation of driving relays.

The digital input is connected between the ”DIO” terminal and common ”COM”. The I/O circuit includes a LED indicator which is lit when the digital input is active, that is, when the input circuit is closed. Provided the resistance of the switching device is less than 200 ohms, the device will be able to activate the digital input.

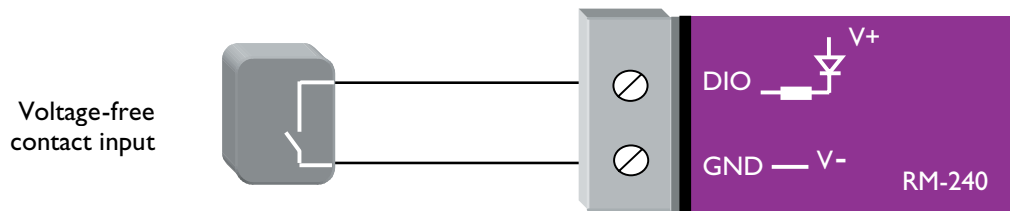

The I/O channel may also be used as a discrete output. The digital outputs are transistor switched DC signals, FET output to common rated at 30VDC 500 mA.

The output circuit is connected to the ”DIO” terminal. The digital output circuit includes a LED indicator which is lit when the digital output is active.

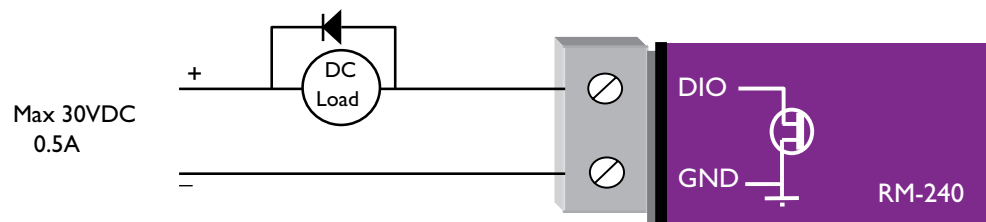

3.1 Start-up

“Access Point” Start-up

An Access Point unit starts and immediately begins transmitting periodic messages called beacons. These beacon messages are messages contain information for Clients on how to establish a link with the Access Point.

Any Client that hears the messages, which are not already linked to another Access Point unit, will respond and links will be established between the new Access Point and these Clients.

“Client” Start-up

When a Client powers up, it immediately scans for messages from Access Point units. The Client will continue to scan for twice the configured beacon interval in the Client. During the scan, the RX led will flicker now and again indicating messages received, perhaps from an Access Point. If the Client finds suitable Access Points during the scan, it will then attempt to establish a link with the Access Point with the strongest radio signal.

Link Establishment

When the Client wishes to establish a link with an Access Point it follows a two step process. The first step is “authentication”. During this step the Client and Access Point check if they can establish a secure link, based upon the configured security encryption. Once the Client has been authenticated, it will then request a link. This step is called “association”.

While no links have been established, the LINK led will be OFF. Once a single link has been established, the LINK led is ON.

After the link is established, data may be transferred in both directions. The Access Point will act as a master-unit and will control the flow of information to the Clients linked to it.

The maximum number of 255 Clients may be linked to an Access Point.

How a Link connection is lost

The Access Point refreshes the link status with a Client every time a message is received from that Client. If nothing is received from a Client for a period of 120 seconds, the Access Point sends a “link-check” message. If there is no response to the link-check a De-authenticate message is sent and the link is dropped.

A Client monitors beacons from an Access Point to determine whether the link is still present. If the Client can no longer receive beacons from the AP, the AP is considered to be out-of-range and the link is dropped. Whenever a Client is not connected to an AP, it will cyclically scan all available channels for a suitable AP.

Roaming

Clients may also roam between Access Points. If a Client receives a beacon from an AP with a stronger signal than the current AP (providing SSID is the same and capability information are compatible), it may disconnect from the first AP and establish a link with the second AP. This functionality permits a client to have mobility whilst maintaining a link with the most suitable AP.

LED Indication

The following table details the status of the indicating LEDs on the front panel under **normal** operating conditions.

LED Indicator	Condition	Meaning
OK	GREEN	Normal Operation
OK	RED	Supply voltage too low.
Radio RX	GREEN flash	Radio receiving data
Radio RX	RED flash	Weak radio signal
Radio TX	Flash	Radio Transmitting
Radio LINK	On	On when a radio communications link is established
Radio LINK	Off	Communications failure or radio link not established
Radio LINK	GREEN flash RED flash	Serial Port Receiving CTS low
LAN	ON	Link Established on Ethernet port
LAN	Flash	Activity on Ethernet port.
Serial	GREEN flash	RS-232 Serial Port Activity
Serial	RED flash	RS-485 Serial Port Activity
DIO	On	Digital Output ON or Input is grounded.
DIO	Off	Digital Output OFF and Input is open circuit.

The Ethernet RJ45 port incorporates two indication LEDs. The LINK LED comes on when there is a connection on the Ethernet port, and will blink off briefly when activity is detected on the Ethernet Port. The 100MB LED indicates that the connection is at 100 MBit/Sec. The 100MB LED will be off for 10MB/Sec connection.

Other conditions indicating a fault are described in Chapter Six **Troubleshooting**.

3.2 Selecting a Channel

The RM-240 conforms to the IEEE 802.11 Wireless LAN specification. The RM-240 supports 11 radio channels, each 5MHz wide, in the range 2412MHz to 2462MHz. Only one of these channels is used for a connection. The desired channel is selected and configured at the Access Point, and is then used for all beacon transmissions and connections. Clients scan all 11 channels for a suitable Access Point and then adopt the same channel as the AP when a connection is established. Although each channel is only 5MHz wide, the radio transmission is a lot wider. Hence the channels overlap. The following diagram shows the RF energy distribution for a WiFi transmission:

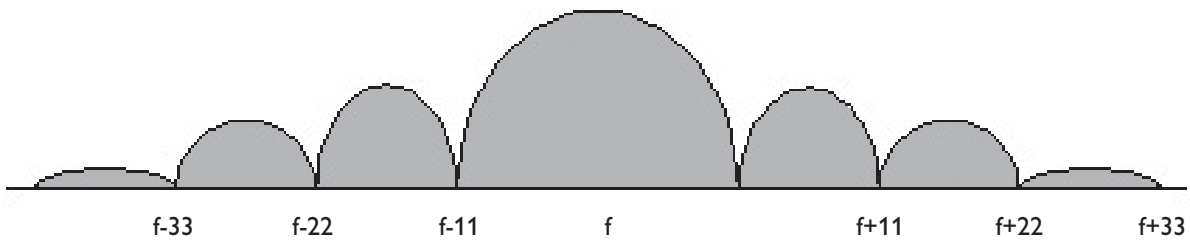

RF power distribution in a WiFi transmission with channel central frequency,

Most of the energy is in a central 22 MHz wide “lobe”, centred around the channel frequency, however there are also side-lobes extending either side.

If we ignore the side lobes and consider each WiFi message as a 22MHz wide transmission, then the following diagram represents how transmissions in each channel overlaps.

If there is more than one WiFi AP within the same wireless range, then it is important that the AP's are on channels as far apart as possible. If there are only two AP's, then set them to 1 and 11. If there are three, set them to 1, 6, 11.

It is also important that correct channel is selected for region. Channels 1 to 11 are approved for North America (FCC), Europe (ETSI), Canada (IC) and Australia (ACMA). Channels 10 and 11 are approved for use in Spain and France. Refer to the relevant regulatory authority for the region as to which radio channels are approved for use.

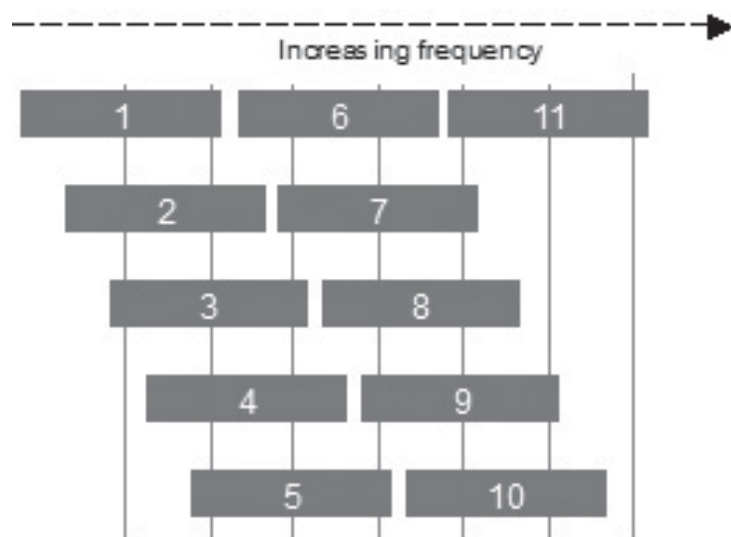

3.3 Default Configuration

The default factory configuration of the RM-240 is

- ⌘ Client/Bridge/
- ⌘ IP address 192.168.0.1XX, where XX is the last two digits of the serial number (the default IP address is shown on the printed label on the back of the module)
- ⌘ netmask 255.255.255.0
- ⌘ Username is “user” and the default password is “user”

The RM-240 will temporarily load some factory-default settings if powered up with the Factory Default switch (on the end-plate of the module) in SETUP position. When in SETUP mode, wireless operation is disabled. The previous configuration remains stored in non-volatile memory and will only change if a configuration parameter is modified and the change saved.

Do not forget to set the switch back to the RUN position and cycle power at the conclusion of configuration for resumption of normal operation.

3.4 Configuring the Unit for the First Time

The RM-240 has a built-in web server, containing webpages for analysis and modification of configuration. The configuration can be accessed using Microsoft[®] Internet Explorer. This program is shipped with Microsoft Windows or may be obtained freely via the Microsoft[®] website.

Configuration of IP address, gateway address and subnet mask may also be accessed via the RS 232 serial port.

Accessing Configuration for the first time

There are two methods for accessing the configuration inside a RM-240. The first method requires changing your computer settings so that the configuring PC is on the same network as the RM-240 with factory default settings. **This is the preferred method** and is much less complicated than the second method. You will need a “straight-through” Ethernet cable between the PC Ethernet port and the RM-240. The factory default Ethernet address for the RM-240 is 192.168.0.1XX where XX are the last two digits of the serial number (check the label on the back of the module).

The second method requires setting an IP address in the RM-240 such that it is accessible on your network without having to change your network settings.

3.4.1 Set PC to same network as RM-240

Connect the Ethernet cable between unit and the PC configuring the module.

- ⌘ Set the Factory Default Switch to the SETUP position. This will always start the RM-240 with Ethernet IP address 192.168.0.1XX, subnet mask 255.255.255.0, gateway IP 192.168.0.1 and the radio disabled. **Do not forget** to set the switch back to the RUN position and cycle power at the conclusion of configuration for resumption of normal operation.
- ⌘ Power up the RM-240 module.

Open “Network Settings” on your PC under Control Panel. The following description is for Windows XP – earlier Windows operating systems have similar settings.

- ⌘ Open “Properties” of Local Area Connection.
- ⌘ Select Internet Protocol (TCP/IP) and click on Properties.
- ⌘ On the General tab enter IP address 192.168.0.1, Subnet mask 255.255.255.0, and default gateway 192.168.0.1.
- ⌘ Open Internet Explorer and ensure that settings will allow you to connect to the IP address selected. If the PC uses a proxy server, ensure that Internet Explorer will bypass the Proxy Server for local addresses. This option may be modified by opening Tools -> Internet Options -> Connections Tab -> LAN Settings->Proxy Server -> bypass proxy for local addresses.
- ⌘ Enter the default IP address for the RM-240 `http://192.168.0.1XX` where XX is the last two digits of the serial number
- ⌘ A welcome webpage should be displayed as illustrated below.
- ⌘ Configuration and Diagnostics may be opened by clicking on any of the menu items, and entering the username “user” and default password “user”. Configure the unit to your requirements (refer later sections of this manual).

When Configuration is complete, switch Factory Default dip-switch on RM-240 to RUN position, and cycle power to resume normal configured operation.

3.4.2 Set RM-240 to same network as PC

This is the alternate procedure to setting an IP address in the RM-240. Consult your network administrator for an IP address on your network, the gateway IP address, and network mask.

- a) Switch Factory Default dip-switch on RM-240 to SETUP position.
- b) Connect the RS232 port on the RM-240 to the RS232 port on the PC using a “straight-through” serial cable.
- c) Open a terminal package (such as Hyperterminal) with 19.2 kbit/s data rate, 8 data bit, 1 stop, no parity and no flow control. Make sure that no other programs have control of the serial port.
- d) Power up RM-240. Basic network settings will be displayed on the terminal as illustrated below. When prompted, hit enter key to stop automatic boot process. You have 5 seconds to abort the boot process.
- e) Check values for Boot Address, Boot Netmask, and Boot Gateway. These values should be set to reflect those of the PC you are using to configure the unit. If these are correct skip to step (h). You may check settings again with the `rct` command. For further help, type the help command.
- f) Set Boot Netmask to the same settings as the computer you have the Ethernet cable connected to. This may be performed with the command: `bnm <Type the netmask>`
- g) Set Boot Gateway to the same settings as the computer you have the Ethernet cable connected to. This may be performed with the command: `bgw <Type the gateway IP address>`
- h) Choose an IP address for the RM-240 being upgraded. This IP address must be on the same network as the computer you have connected the Ethernet cable to. This may be performed with the command: `bip <Type the IP address>`
- i) Switch dip-switch on RM-240 to RUN position.

- j) Type the command reset, or cycle power to the unit. The 240UE will reset and start with the network settings you have entered.
- k) Open Internet Explorer and ensure that settings will allow you to connect to the IP address selected. If the PC uses a proxy server, ensure that Internet Explorer will bypass the Proxy Server for local addresses. This option may be modified by opening Tools -> Internet Options -> Connections Tab -> LAN Settings->Proxy Server -> bypass proxy for local addresses.
- l) Enter the webpage *http://xxx.xxx.xxx.xxx/* where *xxx.xxx.xxx.xxx* is the IP address selected for the module. A welcome webpage should be displayed as illustrated.
- m) Clicking on any of the menu items, and entering the username “user” and password “user” may open Configuration and Diagnostics. If the password has previously been configured other than the default password, then enter this instead.

3.5 Network Configuration

You can view or modify Ethernet network parameters by selecting the “Network” menu. When prompted for username and password, enter “user” as the username, and “user” as the password in the password field. If IP address or password has been forgotten, the Factory Default switch may be used to access the existing configuration. Refer to section 3.3 above.

The Network Configuration page allows configuration of parameters related to the wired and wireless Ethernet interfaces. In general, IP address selection will be dependant upon the connected wired Ethernet device(s) – before connecting to an existing LAN consult the network administrator.

A system of RM-240's must have at least one Access Point acting as a master to one or more Clients. All RM-240's to be configured as part of the same wireless network should be given the same System Address (SSID) and Radio Encryption settings. For further information and examples on wireless network topologies refer section 1.1 above.

The RM-240 supports several different radio encryption schemes. WEP (*Wired Equivalent Privacy*) encryption is the weakest encryption method, defined by the original IEEE802.11 standard. 64bit and 128bit WEP combine either a 40bit or 104bit key with a 24bit initialization vector, and are intended to provide equivalent security attributes to those of a wired medium. The RM-240 supports both 64bit and 128bit WEP without any performance (throughput) degradation.

WPA (*WiFi Protected Access*) is a subset of the IEEE802.11i Security Enhancements specification. The RM-240 supports WPA-1 TKIP and WPA-2 AES using a Pre-Shared Key (PSK). TKIP (*Temporal Key Integrity Protocol*) enhances WEP by using 128bit encryption plus separate 64bit Tx and Rx MIC (*Message Integrity Check*) keys. Enabling TKIP will degrade the RM-240 radio throughput by approximately half of the rate attainable using either WEP or no encryption. AES (*Advanced Encryption Standard*), the most secure encryption method, is also based on 128 bit encryption key. Enabling AES in the RM-240 will degrade radio throughput to approximately 20% of the rate attainable using either WEP or no encryption.

After changes are made to Network Configuration, it is important to save the configuration by selecting “Save and Reset”.

Network Settings Webpage Fields

Operating Mode	Used to select Access Point (Infrastructure), Client (Infrastructure), IBSS (Ad-Hoc), or MONITOR mode. By default this is set to Client.
Device Mode	Used to select Bridge or Router mode. By default this is set to Bridge.
FTP Enabled	This enables access to volatile memory storage on the RM-240. By default this is disabled.
MAC Address	This is the unique hardware address of the RM-240, assigned in the Factory. For the majority of systems, this item should not be changed. If the device is to be connected to equipment that will only communicate with a set MAC Address, the RM-240 may clone that MAC address.
Gateway IP Address	This is only required if the wired LAN has a Gateway unit which connects to devices beyond the LAN – for example, Internet access. If there is no Gateway on the LAN, set to the same address as the Access Point – that is, the “Ethernet IP Address” below.
Ethernet IP Address	The IP address of the RM-240 on its wired Ethernet port. This should be set to the IP address you require.
Ethernet IP Subnet Mask	The IP network mask of the RM-240 on its Ethernet port. This should be set to the IP address you require.
Wireless IP Address	The IP address of the RM-240 on the wireless port. If the unit is configured as a bridge this address will be the same as the Ethernet IP address. If configured as a router, the IP address must be different from the Ethernet IP Address – it must be consistent with the LAN it is connecting to on the wired side.
Wireless IP Subnet Mask	The network mask of the RM-240 on the radio port. If configured as a Bridge, this must be the same as the Ethernet IP Subnet Mask.
System Address (SSID)	A RM-240 network comprises modules with the same “system address”. Only modules with the same system address will communicate with each other. The system address is a text string 1 to 31 characters in length. Select a text string which identifies for your system.
Radio Encryption	Select “None”, “WEP (64-bit)”, “WEP (128-bit)”, “WPA PSK (TKIP)”, or “WPA PSK (AES)” security encryption of the wireless data. The default setting is “None”.

Encryption Keys 1 to 4	<p>These are the keys used to encrypt radio data to protect data from unwanted eavesdroppers when WEP Encryption is selected. These keys should be the same for all RM-240 units in the same system. One of the four keys may be selected as the default key, and is used to encrypt transmitted messages from the configured unit. A RM-240 can receive and decrypt a message from a module that has a different default key index as long as each module has the same key configured at the same index. WEP keys must be entered as pairs of hexadecimal digits separated by colons. Hexadecimal digits are in the range 0..9 and A..F. 64bit WEP requires 10 Hexadecimal digits, and 128bit WEP requires 26 Hexadecimal digits. For example, 12:AB:EF:00:56. for 64bit encryption, and 12:AB:EF:00:56:15:6B:E4:30:C8:05:F0:8D for 128bit encryption. Encryption keys must not be all zeros, i.e. 00:00:00:00:00</p>
Passphrase	<p>When WPA Encryption is selected, 128bit Encryption keys are internally generated based on the Passphrase and System Address (SSID). The Passphrase must be between 8 and 63 characters in length, and the Passphrase must be the same for all RM-240 units in the same system.</p>
Save and Reboot.	<p>Save settings to non-volatile memory, and reboot RM-240.</p>

3.6 Ethernet Data

All Ethernet devices are uniquely identified by a MAC Address that identifies the hardware device. These addresses are factory-set and are six bytes in size and are expressed in hexadecimal in the form `xx:xx:xx:xx:xx:xx`

Ethernet messages can be addressed to a single device (a point-to-point message) or can be directed towards multiple destinations by using Multicast addresses and Broadcast addresses. The broadcast address is used to send data to all devices. The broadcast address is `FF:FF:FF:FF:FF:FF`.

Multicast addresses are used to direct data at a set of devices. Multicast addresses may be recognized as they always have the least significant bit of the first byte of the MAC Address set. For example, `01:00:5E:00:00:00` is a multicast address, `01:80:C2:00:00:00` is also a multicast address.

3.7 Normal Operation

After addresses are configured, the units are ready for operation.

Refer to section 1 for an explanation on the operation of a Bridge and Router.

Transparent Bridge Operation

Bridges are typically used to connect sections of the same IP network together.

By default, the RM-240 is configured as a transparent bridge. When a transparent bridge is started, it learns the location of other devices by monitoring the source address of all incoming traffic. Initially it forwards all traffic between the wired Ethernet port and the wireless port, however by keeping a list of devices heard on each port, the transparent bridge can decide which traffic must be forwarded between ports – it will only transfer a message from the wired port to the wireless port if it is required.

A bridge will forward all Broadcast traffic between the wired and wireless ports. If the wired network is busy with broadcast traffic, the radio network on the RM-240 can be unnecessarily overburdened. Filtering may be used to reduce broadcast traffic sent over the radio. Refer Section 3.11 for how to configure a filter.

By default, a transparent bridge does not handle loops within the network. There must be a single path to each device on the network. Loops in the network will cause the same data to be continually passed around that loop. Redundant wireless links may be set up by enabling the bridge Spanning Tree Protocol (see section “3.9 Spanning Tree Protocol” for more details).

3 or 4 Address Mode

There are two different operating modes that affect bridge operation for a RM-240 client/station – “3-Address Mode” or “4-Address Mode”.

“3-address mode” *must* be used by RM-240 clients when they have to communicate with third party (non-RM-240) Access Points.

However, “4-address mode” (which is also used for multiple Access Point Repeaters), may be used by RM-240 clients when they communicate with other RM-240 Access Points. Address mode configuration can be altered via the Repeaters configuration page.

When 3-address mode is used it is not possible for a RM-240 client to transmit over the radio link the MAC address of any device connected to its wired Ethernet port.

Therefore, the RM-240 client must act as a proxy for devices lying on its wired Ethernet port, and use its own MAC address on their behalf. To do this, it analyzes the IP addresses within the Ethernet frame body and builds a lookup table so that when radio traffic is received it can lookup the device MAC address based on its IP address. This functionality is referred to as *Layer 3 Bridge*. Note that because the layer 3 bridge relies on IP, it is only suitable for bridging Ethernet frames from devices that communicate using IP. For this reason the bridge Spanning Tree Protocol *can not* be used with 3-address mode. When a RM-240 client/station uses 3-address mode any Access Point that it is to communicate with may be configured for either 3 or 4 address mode (i.e. Access Point mode does not matter).

4-address mode allows a RM-240 client/station to bridge traffic from devices connected to its wired Ethernet port without acting as a proxy for their MAC address. This means that a RM-240 client/station in 4-address mode can bridge *any* Ethernet traffic – not just IP based traffic as with 3-address mode. 4-address mode should also be used if the bridge Spanning Tree Protocol is required. When a RM-240 client/station uses 4-address mode any Access Point that it is to communicate with must also be configured for 4-address mode.

Router Operation

A router joins separate Ethernet networks together. The router has different IP addresses on its wired and wireless ports, reflecting the different IP addresses of the separate Ethernet networks. All the devices in the separate networks identify the router by IP address as their gateway to the other network. When devices on one network wish to communicate with devices on the other network, they direct their packets at the router for forwarding.

As the router has an IP address on each of the networks it joins, it inherently knows the packet identity. If the traffic directed at the router can not be identified for any of the networks to which it is connected, the router must consult its routing rules as to where to direct the traffic to. For details on configuring routing rules see section “3.11 Routing Rules”.

3.8 Radio Configuration

The RM-240 can be configured for different radio transmission rates. A reduction in rate increases the reliable range (transmission distance). The factory-default data rate settings are suitable for the majority of applications and should only be modified by experienced users.

The RM-240 allows for configurable fixed or fallback radio transmission Data Rates. When a fixed rate is configured the radio transmission rate is never altered, even under extremely poor conditions. The fallback rates allow a maximum rate to be configured whilst enabling the unit to automatically reduce the rate when transmit errors occur. When a radio transmission is unsuccessful the RM-240 will automatically drop to the next lowest data rate and enter probation. If subsequent transmissions are successful at the lower rate, the RM-240 will attempt to increase to the next highest rate when probation has ended. This can occur when either a specified number of data frames have been successfully transmitted at the lower rate, or when a specified amount of time has elapsed whilst using the lower rate.

The RM-240 also has a configurable “Basic Rate”. The difference between the Basic Rate and the radio Data Rate is that it only applies to multicast radio transmissions and management frames. The Basic Rate is generally set to a lower value than the Data Rate since multicast transmissions have no inherent error correction mechanism.

Select the “Radio” Menu to change the following configuration parameters. If a change is made, you need to select “Save Changes” to retain the changes. Changes will not take effect until the unit is reset.

Power Level	The RF power level is shown in this field. This value is read only and cannot be altered.
Data Rate	The radio baud rate in Mega (million) bits per second (Mbit/s) for point to point radio transmissions. The default value is Auto.
Basic Rate	The radio baud rate in Mega (million) bits per second (Mbit/s) for multicast messages and management frames. These frames include beacons, authentication, association, etc. The default value is 1Mbit/s.
Channel	Radio Channels 1 to 11 may be configured at the Access Point. Refer Section 3.2. By default radio channel is set to 3.
Retry Limit	The number of times a radio transmission will be retried if an acknowledgement is not received. The default value is 7.
Beacon Interval	This interval is the period between beacon transmissions sent by an Access Point. The default value is 100 milliseconds, and it may be adjusted from 50 to 4095 milliseconds.

Fallback Probation Counter	When one of the fallback data rates is selected, the radio data rate may be upgraded to the next highest rate after this many consecutive successful transmissions. The default value is 10.
Fallback Probation Timer	When one of the fallback data rates is selected, the radio data rate may be upgraded to the next highest rate after this amount of time is spent at a lower rate. The default value is 20 seconds.
Disable SSID broadcast.	This should be used to prevent unwanted eavesdroppers from detecting the radio network System Address (SSID) by passively listening to beacon transmissions from the Access Point. When disabled, Access Points will not transmit the System Address openly in Beacon messages. This is particularly useful in unencrypted radio networks.
Disallow Probe Requests without correct SSID	This should be used to prevent unwanted users from detecting the radio network System Address (SSID) actively by sending a probe request to the Access Point. When Disallowed, if the correct System Address is not supplied in the probe request, the Access Point will not respond. This is particularly useful in unencrypted radio networks.
Save Changes	Save changes to non-volatile memory. Changes will not take effect until module is reset.
Save Changes and Reset	Save changes to non-volatile memory and reset module

3.9 Spanning Tree Algorithm / Redundancy

The bridge “Spanning Tree Protocol” function was introduced to handle network loops and provide redundant paths in networks. To enable the STP requires that WDS mode also be enabled on the “Repeaters” configuration page. When enabling WDS mode on a client/station you should ensure that WDS mode is also enabled at the corresponding Access Point – refer section “3.10 Repeaters” for more information.

For example, consider this network with a redundant wireless link. If the bridge Spanning Tree Protocol is enabled, one of the two wireless links will be disabled – that is, all wireless data will be transferred by one link only. If the active link fails, the other link will automatically start transferring the wireless data.

The Spanning Tree Protocol implemented is IEEE 802.1d compatible. The algorithm forms a loop-free network by blocking traffic between redundant links in the network. These blocked links are placed in a standby condition, and may be automatically enabled to repair the network if another link is lost. The Spanning Tree Algorithm maintains a single path between all nodes in

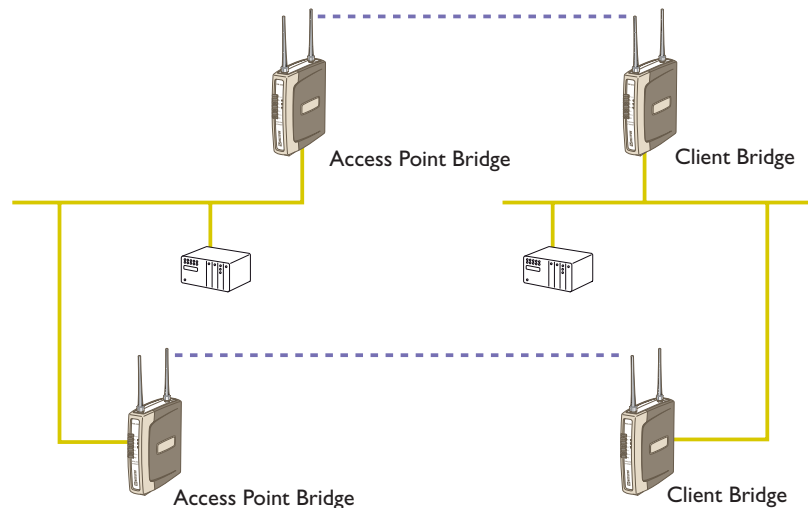

a network, by forming a tree-like structure. The Bridge Priority determines where the node sits in the tree. A Bridge configured with the lowest priority (0) will become the root node in the network, and will direct traffic between each of its branches. The root node is typically the unit that handles the majority of traffic in the network. The RM-240 is configured with a Bridge Priority of 32768 by default. The intention is to reduce traffic that the RM-240 must handle, by placing it at the branch level in the network tree. As a branch, the RM-240 needs only pass traffic to devices that are its “leaves”.

There is some overhead in maintaining a network utilizing the Spanning Tree Algorithm. Users wishing to increase their throughput, at the expense of redundancy should disable Spanning Tree. The Spanning Tree Protocol can be configured on the *Repeaters* configuration page – note that 4-address mode *must* be enabled if the bridge Spanning Tree Protocol is to be used (refer section “3.7 Normal Operation” for details).

3.10 Multiple AP Repeater Mesh Network

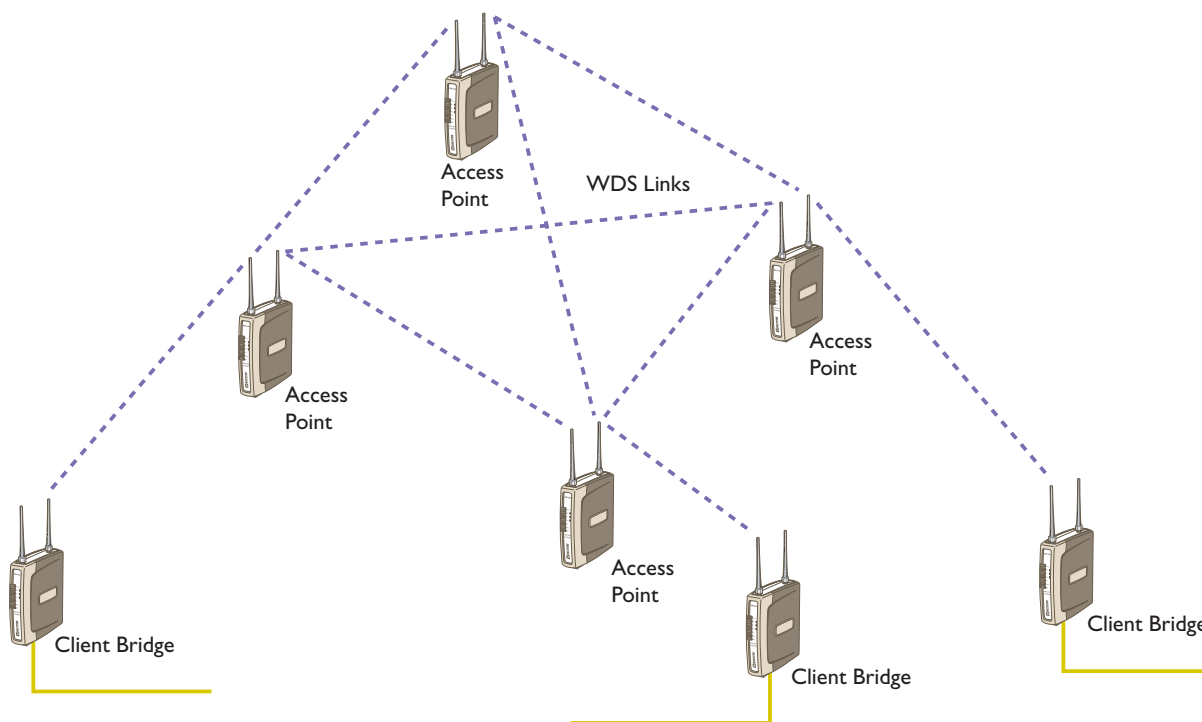

The range of a wireless network can be extended by allowing Access Points to behave as repeaters and forward traffic to other Access Points. Access Point to Access Point communications is also known as Wireless Distribution System (WDS). The RM-240 offers very powerful WDS configuration, allowing for a *mesh* network with self-healing and automatic node discovery. Alternatively, fixed AP to AP links can be configured for optimized throughput.

WDS Access Points require IEEE802.11 4-address mode. 4-address mode may also be used by RM-240 clients when Ethernet protocols other than IP are to be used – see section “3.7 Normal Operation” for more details.

Each RM-240 Access Point supports up to 6 separate *interfaces* for WDS links to other Access Points.

Current RM-240 firmware supports WEP encryption for WDS links – but does not support WPA encryption. WEP keys should be the same for all Access Points that are to communicate with each other.

Each WDS interface can be either a *bridge or router* interface (refer section “1.1 Network Topology” for more information on bridge vs router). If you need a simple repeater network, use a bridge interface.

A WDS *bridge* interface allows traffic to be bridged to another Access Point on the same IP network. WDS bridge interfaces do not require additional IP Address configuration, as they are bridged with the standard *wireless interface* that is used for connections to associated clients. All 6 WDS interfaces on the one Access Point may be bridged if required.

RM-240 WDS bridge interfaces have the advantage that redundant paths are permitted when using the bridge Spanning Tree Protocol (see section “3.9 Spanning Tree Protocol”), thus providing self-healing characteristics. Bridged networks are also not as configuration intensive as routed networks. Since WDS bridge interfaces generally do

not require IP address configuration (they inherit the IP address of the standard wireless interface), they can be configured to automatically connect to other WDS enabled Access Points.

A WDS router interface allows traffic to be routed to an Access Point on a different network, and therefore requires configuration of an IP address to reflect the network address of the destination network. WDS router interfaces cannot provide the redundancy of bridge interfaces, but can be used to reduce radio bandwidth requirements because the router can determine the destination based on IP address, whereas the bridge must go through a learning phase where all broadcast traffic must be retransmitted on each interface. Routed networks may also be used in some cases to avoid the overhead introduced by the bridge Spanning Tree Protocol when network loops exist.

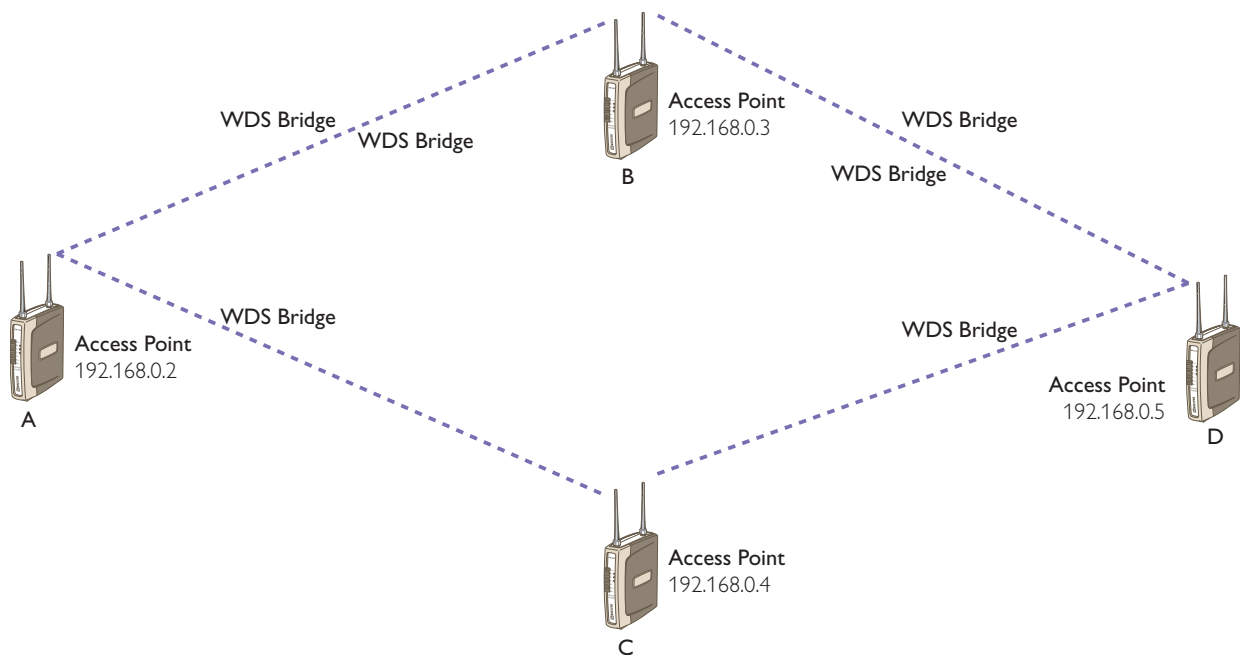

In the above example, 4 Access Points (A, B, C, and D) form a mesh network using only WDS bridge interfaces. Each of the Access Points may also have its own clients associated. A, B, C, and D can all exchange data with each other (as can all of their clients) as if they were all on the same wired segment. It can be seen that there are redundant paths and also the possibility for loops to occur, so that the bridge Spanning Tree Protocol should be enabled. To illustrate the redundancy, consider that if A needs to send data to D it has redundant paths through both B and C. However, due to the spanning tree protocol only one of B or C will relay the data, with the other taking over in the event of a failure.

The configuration for unit A from the WDS bridge example is shown below (this page is accessible via the *Repeaters* link from the configuration web pages). It can be seen that “WDS” mode and “Bridge Spanning Tree Protocol” are enabled, and “Auto Connect to WDS enabled AP’s” is selected. Note that auto connect mode requires that none of the Access Points disable their “SSID broadcast”, otherwise they must have the same SSID. If this is not the case the connections must be manually entered into the WDS connection list (described later). The WDS configurations for units B, C, and D are identical to A.

An example of using WDS router interfaces to achieve a similar physical topology to the WDS bridge example discussed earlier is illustrated below. In both examples, there

are four WDS Access points each with the possibility of having their own client/stations associated. In both examples A, B, C, and D can all exchange data with each other. The bridged example has the advantage of redundancy but at the expense of extra overhead. The routed example below cannot provide the redundancy of the bridged example, and requires more configuration effort, but does not have the overhead of using the bridge Spanning Tree Protocol, so is suited to fixed installations that do not require redundancy.

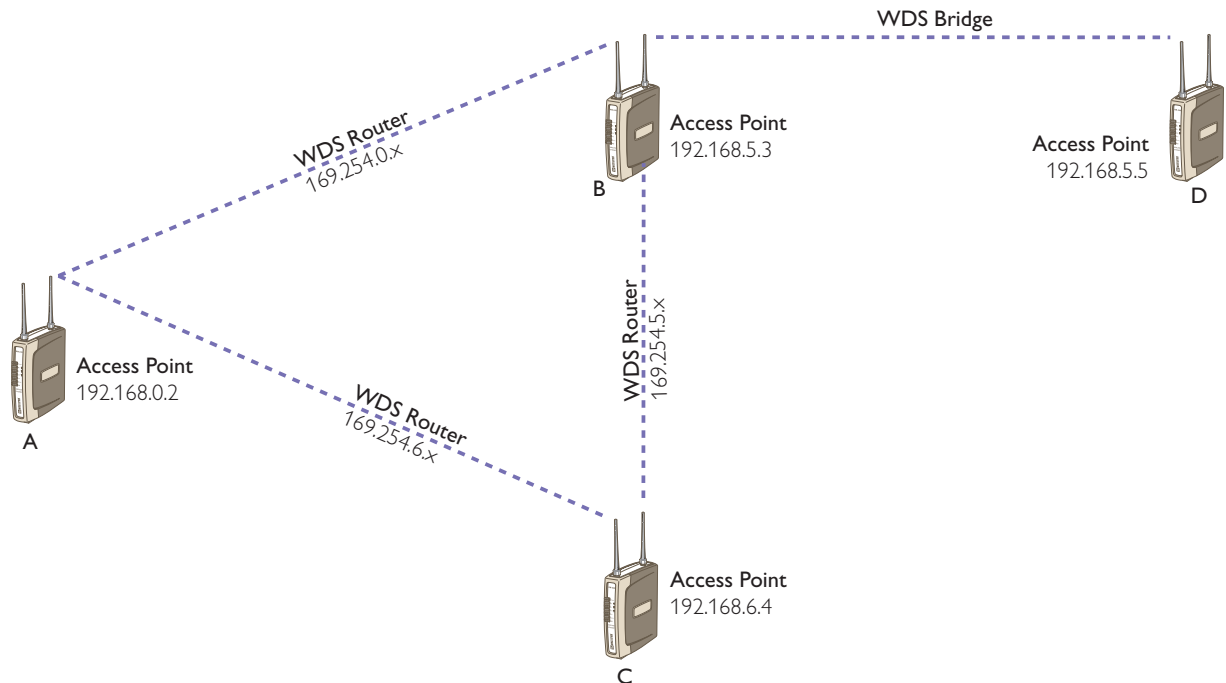

As mentioned previously, configuration of the WDS router example is more complex than the bridged example given earlier. In this case, all Access Points have different SSID's and none of them have SSID broadcast disabled so that WDS configurations can be made without knowledge of Access Point MAC addresses. If SSID broadcasts were disabled, each configuration entry would require an SSID *and* a MAC address (this is because both SSID *and* MAC addresses are required to establish a link – but the MAC address is always broadcast in beacons whereas the SSID broadcast is configurable).

Unit B in the WDS router example above has three WDS links – to units A, C, and D; we show unit B's configuration below. It can be seen that there are 3 entries in the WDS Connections list. The first entry specifies a connection to the Access Point whose SSID is "A", and that it is to be a WDS router interface with Router IP address 169.254.0.3 (this is the address that unit B adopts for the router interface link to unit A). Note that this IP Address specifies a different network than that of the default interface for unit B (i.e. default interface network 192.168.0.x compared to WDS interface network 169.254.0.x). It is a requirement that the interfaces at each end-point of a WDS link have the same network address, so by using a different network address to that of the default interface we ensure that each end point has a different *network* address than its default interface. This ensures that the WDS links at either end point are not bridged with their default interface, since in this example we wish to eliminate the overhead associated with a bridged interface.

A consequence of using a different network address for the WDS link between unit A and B, is that we now need to configure a *routing rule* at units A and B so that the RM-240 can determine where to send traffic destined for the respective network addresses of A and B. For example, if unit B receives traffic destined for network 192.168.0.x (i.e. somewhere on unit A’s network), the routing rule specifies that the traffic must be forwarded to the end point of the WDS link to unit A. The routing rules for unit B are shown below (for more information on routing rules, refer to the section “3.11 Routing Rules”).

The second WDS entry specifies the WDS link to unit C as a WDS router interface with IP address 169.254.5.3. As with the WDS link to unit A, we use a different IP network address than the default interface (note that this network address 169.254.5.x is also different to that used for the WDS link to unit A 169.254.0.x, so that these separate WDS interfaces are not internally bridged). Also, as with the WDS link to unit A, a routing rule is added to direct traffic destined for the network address of unit C (192.168.6.x). So, in this example, unit B has a total of three IP addresses: 192.168.5.3 for the default interface; 169.254.0.3 for the WDS link to unit A; and 169.254.5.3 for the WDS link to unit C. Note that we choose to always use the same *host* address of 3 for unit B on all of its interfaces regardless of the network address.

The third WDS entry specifies the WDS link to unit D. In the example unit D has the same network address as unit B, therefore we wish to have the WDS interface link to unit D bridged with the default interface. Because we don’t specify a router IP address for the third entry the RM-240 automatically bridges this interface with the default wireless interface.

The routing rule for directing traffic to unit A can be seen to specify 192.168.0.0 as the destination address (the network address of unit A) – because the last byte is zero, this refers to a route to the network 192.168.0.x (as opposed to a route to an individual *host*). The same rule specifies the address 169.254.0.2 as the gateway address (this is the WDS Router IP address that unit A has been configured with for its WDS link to unit B). So, this routing rule effectively tells the RM-240 that any traffic destined for the network 192.168.0.x should be forwarded to unit A via the WDS link. Units A and C would also require similar pairs of routing rules to direct traffic to the network addresses at the end points of their respective WDS links. For unit D it would suffice to simply configure unit B as its default gateway, as unit B would then forward on any traffic destined for units A and C. Refer to section “3.11 Routing Rules” for further information on routing rules.

The WDS Configuration page is accessible from the “Repeaters” link on any of the configuration web pages. The configurable WDS parameters are summarised below.

Layer 3 bridge	When WDS communications are not required, select this option (see section “3.7 Normal Operation” for details on Layer 3 bridge).
WDS	Select WDS to enable Access Point to Access Point communications.
Bridge Spanning Tree Protocol	Select this to enable Bridge Spanning Tree Protocol when the default radio interface is bridged (see section “3.9 Spanning Tree Protocol”).

Bridge Priority	The bridge priority when the Spanning Tree Algorithm is enabled. Defaults to 32768 with minimum of 0 (highest priority), maximum of 65535 (lowest priority).
Auto connect to WDS Enable AP's	Attempt to automatically establish WDS links with other Access Points – even if those Access Points are not present in the list (NOTE – requires that Access Points that are not in the list do not have “SSID broadcast” disabled, otherwise the SSID is assumed to be the same as this Access Point; Auto connect interfaces will always be bridged with the default wireless interface).
Only connect to AP's in list	Only attempt to establish WDS links with Access Points identified in the list.
Maximum WDS connections to this device	Each RM-240 Access Point supports a maximum of 6 WDS links direct to other Access Points. However the maximum may be reduced – this can be useful when Auto Connect is used.
SSID	Specify the SSID of the Access Point(s) to establish a WDS link with. Leave this field blank if you wish to nominate the Access Point by MAC address only – however in that case the Access Point must not have “SSID broadcast” disabled.
MAC Address	Specify the MAC address of an Access Point to establish a WDS link with. Leave this field blank if you wish to connect to any Access Point with the nominated SSID
Router IP	Leave this field blank if this WDS interface is to be bridged with the default wireless interface. Otherwise enter the IP address for this Access Point that specifies the IP network to route messages to.
Router Subnet	Leave this field blank if this WDS interface is to be bridged with the default wireless interface. Otherwise enter the subnet mask of the network to route messages to.
STP	Applicable to WDS Router interfaces only. If two or more WDS router interfaces having the same Router IP Address and Subnet mask become active the RM-240 must internally bridge them. Select the STP option if you wish to enable the bridge Spanning Tree Protocol for the bridge if this interface is added.

3.11 Routing Rules

When a RM-240 receives an IP frame that is destined for an IP address on a different network, it checks if the network address matches the network address of one of its own interfaces (i.e. hard wired Ethernet, or wireless Ethernet, or WDS) and forwards the frame appropriately. However, if the IP network address does not match any of its interfaces, the RM-240 will forward the frame to its default gateway. In this case it is assumed that the default gateway has a valid route to the destination.

In some cases it is not practical to have just one default gateway (i.e. routed wireless networks with more than two RM-240 routers; and in some cases when WDS router interfaces are used). If more than one “next-hop router” is required, the RM-240 allows for up to 30 *routing rules* to be configured. A routing rule specifies a destination network (or host) IP address and the corresponding next-hop router that messages for the specified destination will be forwarded to. It is assumed that the next-hop router (*or gateway*) will then deliver the data to the required destination (or forward it on to another router that will).

The above network diagram illustrates a situation where routing rules may need to be configured. In this example, the RM-240 clients need only specify the Access Point as their default gateway (i.e. they require no routing rules be configured). However, for the Access Point to be able to deliver traffic to LAN B and LAN C it needs to have routing rules configured that specify the respective RM-240 client/routers as next-hop routers (i.e. gateways) to networks B and C. Note that devices on LAN A should specify the RM-240 Access Point as their default gateway. An alternative to adding routing rules to the RM-240 in this example would be for each device on LAN A that needs to communicate with LANs B and C to independently have routing rules specifying the RM-240 clients at B and C as gateways to those networks.

The routing rules for the Access Point in the above example are shown below. The first entry shows the route to LAN B. The gateway for the route to LAN B is configured as the wireless IP address of the RM-240 client connected to LAN B. The destination for the route is configured as the network address of LAN B. Because the host id of the destination IP address is 0, it specifies a network address. Consequently, any traffic received at the Access Point with destination IP address 169.254.109.x

(where x is any host id) will be forwarded to the RM-240 at LAN B.

The Routing Rules configuration page can be accessed by selecting the “Routing” link on any of the configuration web pages. Up to 30 routing rules may be added to each RM-240. The table below summarises the configurable parameters a routing rule.

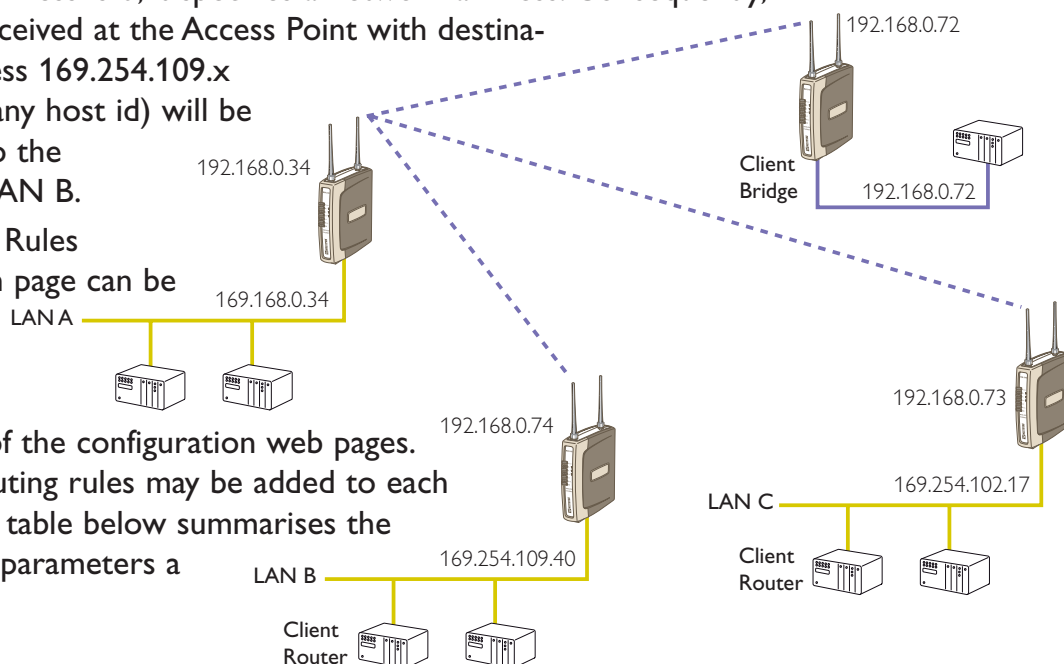

Name	A name to describe the routing rule (Max 32 characters).
Destination	The destination network (or host) IP address (to specify a network address set the host address to 0. i.e. for a class C IP address 192.168.0.0 would specify a destination network, while 192.168.0.16 specifies a destination host).
Gateway	The IP address of the next-hop router for the specified destination.
Subnet Mask	The subnet mask for the destination network.

3.12 Wireless Message Filtering

When configured as a Bridge, the RM-240 will transmit all broadcast messages appearing at its wired Ethernet port. When the RM-240 is configured as a Router, this does not occur.

In many cases, the intended recipient of the broadcast traffic does not lie at the opposite end of a proposed radio link. Reducing unnecessary broadcast traffic sent over the radio link, will increase available bandwidth for data. The RM-240 has a filtering feature to help reduce unnecessary wireless transmissions and enhance security.

The RM-240 may be configured to reject or accept messages to and from certain Addresses. To accept wireless messages from particular devices a “Whitelist” of Addresses must be made. Alternatively to reject messages from particular devices, a “Blacklist” of Addresses must be made. Filtering applies only to messages appearing at the wired Ethernet port of the configured RM-240.

The Filter comprises of two lists: one of MAC Addresses and another listing IP protocol details. Each list may be set as either a blacklist (to block traffic for listed devices and protocols), or as a whitelist (to allow traffic for listed devices and protocols). The Filter operates on two rules listed below.

1. A Blacklist has priority over a whitelist. Traffic matching detail in a blacklist will be discarded if it also appears in a whitelist.
2. When one or both lists are whitelists, traffic must have matching detail in at least one of the whitelists for it to be passed. Note that, as this must agree with rule 1 above, the traffic detail must not match anything in a blacklist, if present, for it to be passed.

When configuring a Whitelist it is important to add the Addresses of all devices connected to the RM-240 wired Ethernet port, that communicate over the wireless link. It is particularly important to add the Address of the configuration PC to the Whitelist. Failure to add this address will prevent the configuration PC from making any further changes to configuration. Design of the filter may be simplified by monitoring network traffic and forming a profile of traffic on the wired network. Network Analysis software, such as the freely available Ethereal program, will list broadcast traffic sent on the network.

For example, Computer B sees the computer D via Ethernet Modems C & E. The White Filtering requires that at Modem C has computer B in its white list, Modem E has computer D in its Whitelist. Computer A will be not be able to access Computer D, as Computer A is not present in the Whitelist in Modem C.

If radio links are chained together to form a radio backbone, it is also important to consider the operation of the Layer 3 Transparent Bridge (Refer Section 3.7). A RM-240 Client will act as a MAC Address translator, as it acts as a MAC address proxy on behalf of devices connected to its wired Ethernet port. Addition of RM-240 Client MAC addresses into intermediate RM-240 units' whitelist filters may be required for correct operation.

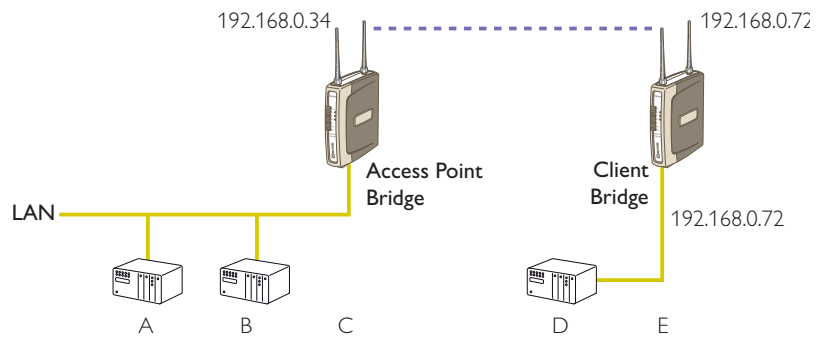

It is advisable to use the Apply Changes button to test the configuration entered. Once the configuration is determined to be correct, the Apply Changes and Save button should be used. In the event that the configuration is incorrect, a power reset will revert the unit to previously saved configuration.

If an erroneous configuration has prevented all access to the module, SETUP mode may be used analyze what is wrong with the configuration. Simply switch the dipswitch to SETUP and cycle power. The RM-240 will retain its configuration, however will load up at IP address 192.168.0.1XX, netmask 255.255.255.0 with the radio and filter disabled. The XX in the IP address is the last two digits of the serial number. Configuration webpages will still show the original configuration. No changes are made to configuration until the user saves changes. To resume normal operation, set the dipswitch to RUN and cycle power.

MAC Address Filter Configuration:

Add Entries	Enter the MAC addresses of devices to be added to the list. Multiple entries must be separated by a semi-colon (;).
Delete Entries	Check the box alongside entries selected for removal from the list.
Whitelist or Blacklist	Check the box to make the list a whitelist. This will allow devices with the MAC addresses listed to communicate with the module and utilize the radio link. All other devices are blocked unless they exist in an IP whitelist. Uncheck the box to make the list a blacklist. This will prevent all listed devices from using accessing the module and using the radio link.
Apply Changes	Update settings.
Apply Changes and Save	Update settings and save to non-volatile memory.

IP Address Filter Configuration:

Add Entries	Enter the details of IP traffic to be added to the list. Protocols ARP, ICMP, TCP and UDP may be selected. Other IP protocols may be selected provided the IP protocol number within packets is known. TCP and UDP traffic may be also limited to specific port numbers.
Delete Entries	Check the delete box alongside entries selected for removal from the list. Alternatively, check the enable box alongside entries if you want to make the rule active.
Whitelist or Blacklist	Check the box to make the list a whitelist. This will only allow traffic described in the list to be sent over the radio link. All other traffic is blocked unless it is present in a MAC whitelist. Uncheck the box to make the list a blacklist. This will ban all traffic described in the list from being sent to the module or over the radio link.
Apply Changes	Update settings.
Apply Changes and Save	Update settings and save to non-volatile memory.

NOTE: When configuring a TCP filter it is often desirable to also configure both an ARP and an ICMP filter for the same IP Address range. The ARP filter is required whenever the sending device does not have a fixed IP to MAC Address translation table entry (i.e. whenever the device may need to send an ARP request to determine the MAC address of a device with a known IP Address). An ICMP filter is needed to allow/disallow “pings”.

3.13 Serial Port Configuration

The RM-240 has an RS-232, and RS-485 port for serial communications. These ports may be used for different purposes. The RM-240 offers three different serial functions which are PPP server, Serial Gateway, and Modbus TCP to RTU server.

3.13.1 RS-232 PPP Server

The RM-240 can be used as a PPP Server to connect the wireless Ethernet system to serial devices via the RS232 or RS485 serial ports.

PPP Server enables a network connection to the RM-240 over a serial cable. This is much like dial up internet. The maximum serial data rate is 115.2 kbit/s. Hardware or Software flow control may be selected.

With minimal configuration on the PC, you may use Dial up networking in Windows XP to connect to the network via the serial port.

For the RM-240, users must configure the local IP address for the RM-240 and the remote device IP address. Some care must be taken in selecting these IP addresses.

If you wish to use routing over this serial network connection, then the IP addresses selected must not lie on Wireless or Wired Ethernet networks already configured into

the device. You must ensure they set routing rules appropriately for devices either side of the network.

If you want the serial device visible as present on the Wireless or Wired network, then the local IP address must be the same as the IP address set for the desired port. A process called "Proxy ARP" is used to make the device visible on the network. In this process, the RM-240 pretends that it holds the IP address on the network, and responds on behalf of the remote device.

The result of this is similar to bridging for a single device, with some exceptions. One of these exceptions is the inability to handle name server searches of the network via this serial link. For example, you would encounter difficulty if you were to use Windows Explorer over the serial link to find a PC on the wired network. For this to operate correctly you must explicitly map computer names to IP addresses in the "LMHOSTS" file on your PC.

When in SETUP mode, the RM-240 PPP server is enabled. This may also be used to configure the module. Settings whilst in SETUP mode are as follows:

- ⌘ username user, password is user.
- ⌘ Serial baud rate 38.4 kbit/s
- ⌘ Hardware flow control
- ⌘ Local address 192.168.123.123
- ⌘ Remote address 192.168.123.124

To configure Windows XP to establish a PPP connection to a RM-240 in SETUP mode, follow these steps:

1. On Network Connections in Windows XP, select Create a new connection
2. On the New Connection Wizard, click Next
3. Set up an advanced connection
4. Connect directly to another computer
5. Set PC as guest
6. Set Computer Name
7. Select a COM port
8. Select availability
9. Click Finish
10. Select properties of this new connection by right clicking on connection.
11. General Tab click on Configure button
12. Ensure maximum speed is 115.2 kbit/s, click OK
13. Select Networking Tab -> click on Internet Protocol (TCP/IP) in list box and then click Properties button.
14. On Properties form click Advanced button
15. On Advanced TCP/IP Settings form->General Tab, uncheck field in PPP link stating "Use IP header compression".
16. Configuration is now complete. Click on this newly created link to establish a connection to RM-240.

17. Ensure both the username and the password are entered exactly as configured in RM-240. (When booted in SETUP mode, the PPP server has username “user” and password “user”.)

3.13.2 Serial Gateway

Serial Gateway functionality is available for both RS-232 and RS-485 ports independently, and enables serial data to be routed via the wired or wireless network connection. Serial Gateway functionality is similar to radio modem functionality, allowing point-to-point and multipoint serial data transfer.

Each RM-240 serial port may be configured as Server, Client, or Multicast Group. When configured as Server, the module will wait for a connection to be initiated by a remote client. When configured as Client, the module will automatically attempt to connect to the specified remote server. When configured as Multicast Group, the module will broadcast data to all members of the same Multicast Group.

Some of the possible Serial Gateway topologies are illustrated below. As can be seen, it is possible for serial data from a RM-240 to be transferred to one or more RM-240 serial ports, or to be encapsulated within a TCP/IP socket for availability on an Ethernet network. Conversely, data encapsulated in a TCP/IP socket can be reproduced at a RM-240 serial port. Both RM-240 serial ports and the hard wired Ethernet port can be in use at the same time.

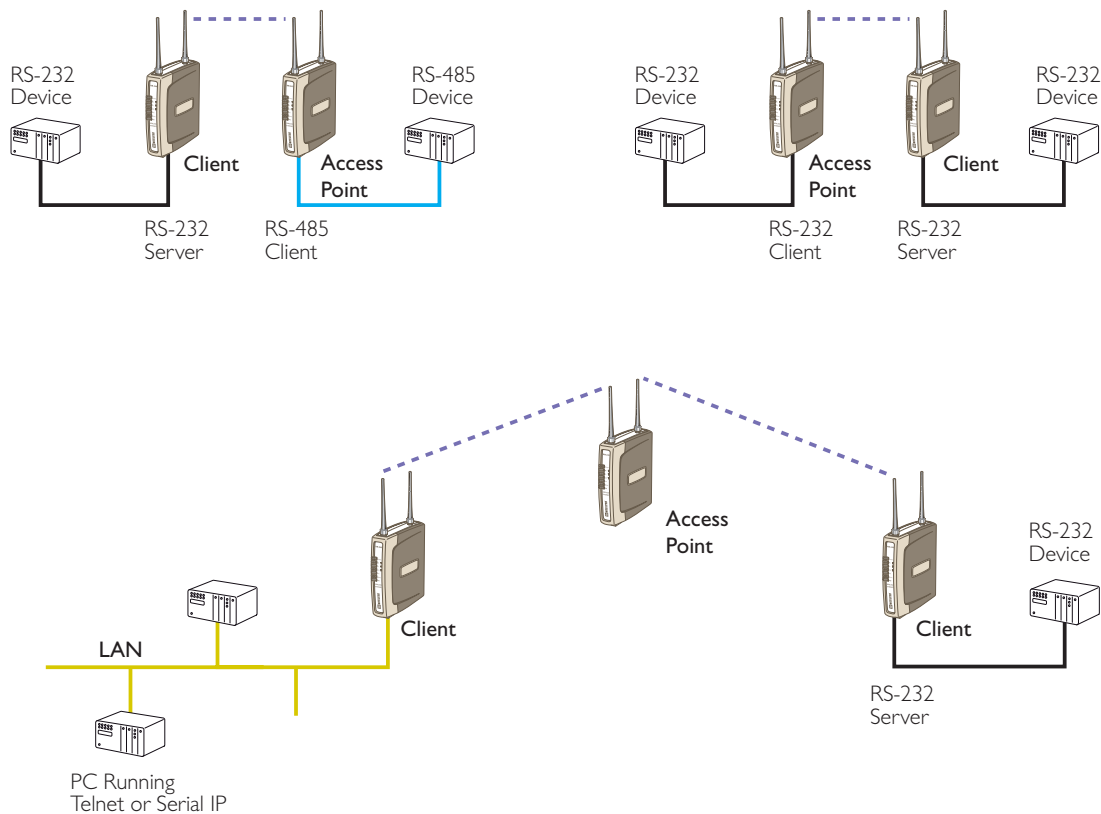

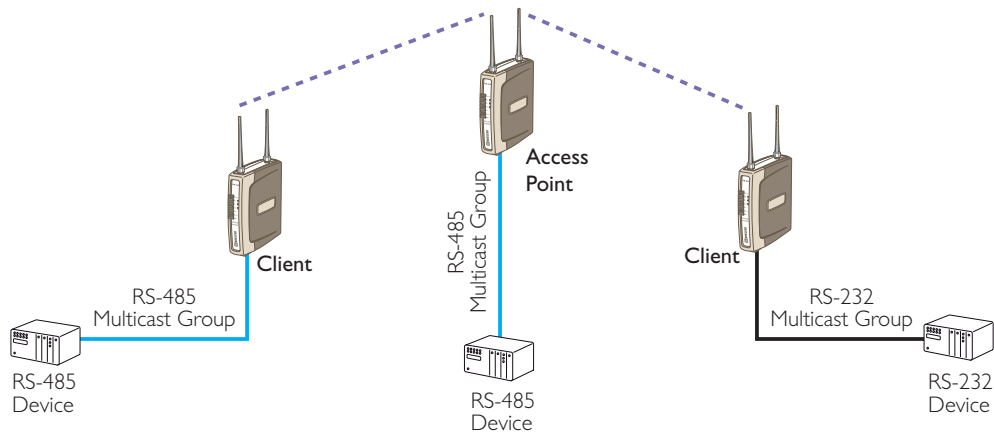

There are software packages available (i.e. Serial IP Redirector by Tactical Software) that can create a virtual serial port on a PC. This virtual serial port can be configured to connect to a RM-240 serial port. Standard programs can then be used to access this serial port as if it were actually connected to the PC. Alternatively the program telnet may be used to connect to a serial port on the RM-240. The telnet command used should be:

TELNET [IP address] [Listen Port]

eg. TELNET 192.168.0.155 23 where the IP address is 192.168.0.155 and Listen Port is 23.

Enable RS-232 PPP Server	Check this box to enable the PPP network server on the RS-232 port.
Enable RS-485 Serial Gateway	Check this box to enable the Serial Gateway Server on the RS-485 port.
Data Rate	The serial data rate desired. Serial data rates available range from 110 bit/s to a maximum of 115.2 kbit/s.
Data Bits Parity Stop Bits	The data format desired. Data formats of 8N1, 7E1, 7O1, 7E2, 7O2 are supported.
Character Timeout	Enter the maximum delay (in msec) between received serial characters before packet is sent via network.
Server	When configured as Server, the module will wait for a connection to be initiated by a remote client
Listen Port	Server Only. Enter the TCP port number on which the server must listen for incoming connections. The standard TELNET port is 23.
Client	When configured as Client, the module will automatically attempt to connect to the specified remote server.
Remote Device Port	Client only. Enter the TCP port number of the remote server (i.e. the remote port to automatically connect to).
Remote Device IP Address	Client only. Enter the IP Address of the remote server (i.e. the remote IP Address to automatically connect to).

Multicast Group Port	Enter the UDP port number that all members of the group will use (i.e. all group members should use the same port number).
Multicast Group IP	Enter a valid Multicast IP Address identifying the group (i.e. all group members should use the same Multicast Group IP Address). Valid Multicast IP Addresses are in the range 224.0.1.0 to 238.255.255.255.

3.13.3 Modbus TCP to RTU Server

The Modbus TCP to RTU Server allows an Ethernet Modbus/TCP Client (Master) to communicate with a serial Modbus RTU Slave. The RM-240 makes this possible by internally performing the necessary protocol conversion. The conversion is always performed by the RM-240 which is directly connected to the Modbus serial device (i.e. only this module needs to have Modbus TCP to RTU Server enabled).

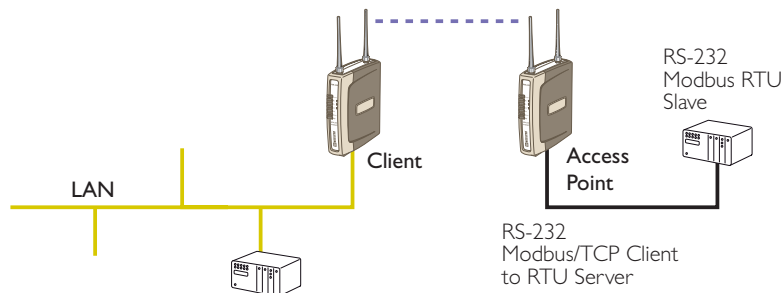

The above example demonstrates how a Modbus/TCP Client (Master) can connect to one or more Modbus RTU (i.e serial) Slaves. In this example the RM-240 Access Point is configured with the “RS232 Modbus/TCP to RTU Gateway” enabled. Once enabled, the gateway converts the Modbus/TCP queries received from the Master into Modbus RTU queries and forwards these over the RS232 port to the Slave. When the serial response to the query arrives from the Slave, it is converted to a Modbus/TCP response and forwarded via the network to the Modbus/TCP Master. If no response was received serially by the RM-240 within the configured Response Timeout, the RM-240 will initiate a number of retries specified by the configured Maximum Request Retries.

The Modbus TCP to RTU Server may be configured to operate on either the RS 232 or RS 485 port. It does not support operation on both ports at the same time.

Enable RS-232 Modbus TCP to RTU Gateway	Check this box to enable the Modbus TCP to RTU Server on the RS-232 port. Only a single serial port is allowed at a time.
Enable RS-485 Modbus TCP to RTU Gateway	Check this box to enable the Modbus TCP to RTU Server on the RS-485 port. Only a single serial port is allowed at a time.
Data Rate	The serial data rate desired. Serial data rates available range from 110 bit/s to a maximum of 115.2 kbit/s.
Data Bits Parity Stop Bits	The data format desired. Data formats of 8N1, 7E1, 7O1, 7E2, 7O2 are supported.

Pause Between Requests	Enter the delay between serial request retries in milliseconds
Response Timeout	Enter the serial response timeout in milliseconds – a serial retry will be sent if a response is not received within this timeout.
Connection Timeout	Enter the TCP connection timeout in seconds – if no Modbus/TCP data is received within this timeout then the TCP connection will be dropped. Set this field to zero for no timeout.
Maximum Request Retries	Enter the maximum number of request retries performed serially.
Maximum Connections	Enter the maximum number of simultaneous TCP connections to the server allowed.

3.14 Digital Input/Output

The shared Digital Input/Output pin may be monitored and set via the internal webpage. As this pin is shared, the Digital Input status will be ON when the Digital Output is set ON.

The Digital I/O channel can also be configured to provide a status output of the module communications. If the RM-240 disassociates from another unit (that is, there is no wireless link), you can configure the digital output to turn ON (set) or OFF (drop).

3.15 Module Information Configuration

Module Information Webpage Fields

This configuration page is primarily for information purposes. With the exception of the password, the information entered here is displayed on the root webpage of the RM-240.

Password Configuration password.	When changing the password on this screen, it will be sent unencrypted over any wired network. If encryption is enabled on the RM-240, any radio communications are encrypted, and therefore hidden from radio eavesdroppers. Caution must only be taken if there are potential eavesdroppers on the wired network.
Device Name	A text field if you wish to label the particular RM-240.
Owner	A text field for owner name.
Contact	A text field for owner phone number, email address etc.
Description	A text field used for a description of the purpose of the unit.
Location	A text field used to describe the location of the RM-240.

3.16 Remote Configuration

Because a module configuration is viewed and changed in a web format (which is an Ethernet application), you can view or change the configuration of a remote module via the wireless link, provided the remote module is already “linked” to the local RM-240.

To perform remote configuration, connect a PC to the local module, run Internet Explorer and enter the IP address of the remote unit – the configuration page of the remote module will be shown and changes can be made. If the remote module is configured as a Router, enter the wireless IP address of the router, not the Ethernet address.

Care must be taken if modifying the configuration of a module remotely. If the Radio Configuration is changed, some changes made may cause loss of the radio link, and therefore the network connection.

It is advisable to determine path of the links to the modules you wish to modify, and draw a tree diagram if necessary. Modify the modules at the “leaves” of your tree diagram. These will be the furthest away from your connection point in terms of the number of radio or Ethernet links.

In a simple system, this usually means modifying the Client modules first and the Access Point last.

3.17 Configuration Examples

Setting a RM-240 to Factory Default Settings

Access configuration webpages of RM-240. Refer section *Accessing Configuration inside a module for the first time, or Modifying an existing configuration.*

1. Click on System Tools Menu Item
2. Enter username “user” and password “user”, when prompted for password.

Click on Factory Default Configuration Reset, and wait for unit to reset. When reset, the LINK LED will flash.

Extending a wired network

Access Point Configuration

Connect straight through Ethernet cable between PC and RM-240.

- ⌘ Ensure configuration PC and RM-240 are setup to communicate on the same network
- ⌘ Set dipswitch to SETUP mode.
- ⌘ Power up unit, and wait for LINK led to cease flashing.
- ⌘ Adjust PC network settings
Set Configuration PC network card with network setting of IP address 192.168.0.1, netmask 255.255.255.0
- ⌘ Open configuration webpage with Internet Explorer at address <http://192.168.0.1XX/> where XX is the last two digits of the serial number
When prompted for password, enter default username “user” and password “user”
Enter “Network”, and select Operating Mode as Access Point.
Select Device Mode as Bridge.
Change the Gateway IP Address to 192.168.0.1
Change the Ethernet and Wireless IP addresses to 192.168.0.200
Change Ethernet and Wireless Subnet masks to 255.255.255.0
Enter a System Address (SSID) string
Select the Radio Encryption required.
Set dipswitch to RUN
Save the changes and unit will restart with new settings.

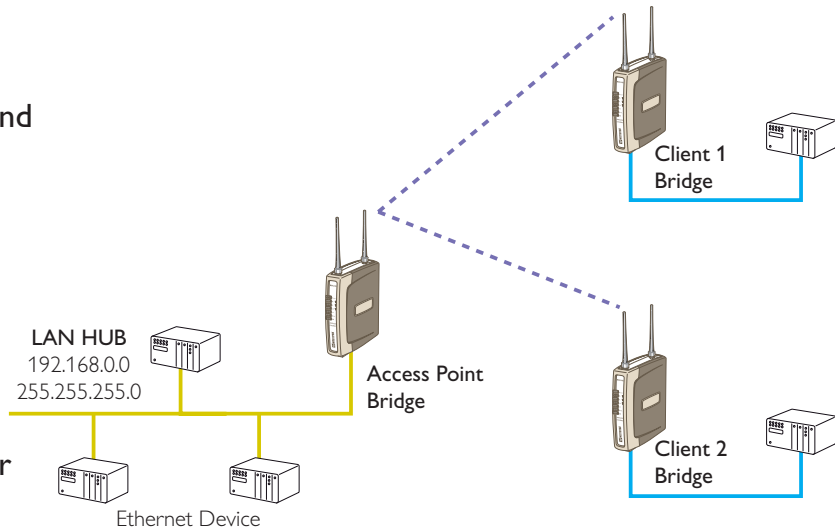

Alternate procedure – Adjust 240U-E network settings using serial port (assuming configuration PC is on existing network)	
a)	Open terminal program with settings with data rate 19.2 kbit/s, 8 data bits, 1 stop bit and no parity.
b)	Set dipswitch to SETUP
c)	Connect straight through serial cable to 240U-E and power up unit.
d)	When prompted, strike the Enter key to abort automatic boot
e)	Set IP address of 240U-E to 192.168.0.200 with command bip 192.168.0.200
f)	Set netmask of 240U-E to 192.168.0.200 with command bnm 255.255.255.0
g)	Set gateway address of 240U-E to 192.168.0.1 with command bgw 192.168.0.1
h)	Set dipswitch to RUN
i)	Reset 240U-E with reset command.
j)	Open configuration webpage with Internet Explorer at address http://192.168.0.200/ When prompted for password, enter default username “user” and password “user” Enter “Network”, and select Operating Mode as Access Point. Select Device Mode as Bridge. Change the IP address to 192.168.0.200 Enter a System Address (SSID) string Select the Radio Encryption required, and enter the system keys. Make a record of these Encryption keys and use these on all modules in the system. Set dipswitch to RUN Save the changes and unit will restart with new settings.

Client 1 Configuration

Perform the same configuration steps as the Access Point configuration with the following differences:

- ⌘ set the Ethernet and Wireless IP addresses of RM-240 to 192.168.0.201
- ⌘ set the Operating Mode to Client.

Ensure the same System Generator String is used and the same Radio Encryption method is selected.

Client 2 Configuration

- ⌘ As above, however set the Ethernet and Wireless IP addresses as 192.168.0.202

Connecting two separate networks together

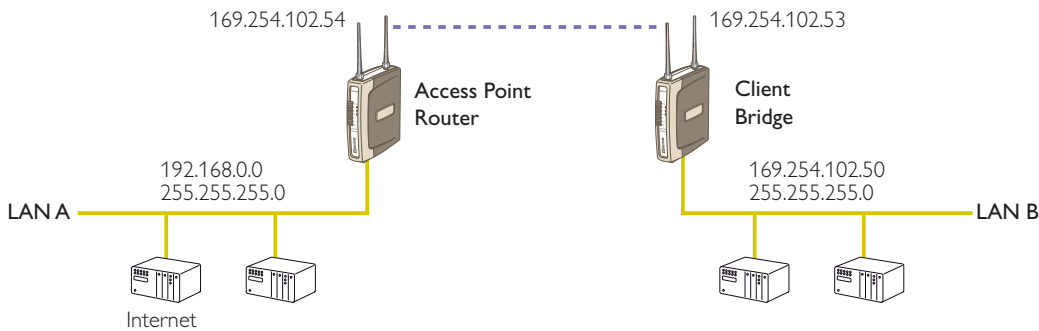

Network A Configuration

In this example, network A is connected to the internet via a router at IP address 192.168.0.1. Devices on Network A that only require access to devices on Networks A and B, should have their gateway IP address set to the RM-240 Access Point as 192.168.0.200.

Devices on Network A, that must interact with devices on Networks A and B and the internet should set the internet router 192.168.0.1 as their gateway, and must have a routing rule established for devices on Network B. On PCs, this may be achieved with the MS-DOS command ROUTE. For this example use: ROUTE ADD 192.168.102.0 MASK 255.255.255.0 192.168.0.200

Network B Configuration

All devices on Network B should be configured so their gateway IP address is that of the RM-240 Access Point as 192.168.102.54

Access Point Configuration

- ⌘ Connect straight through Ethernet cable between PC and RM-240.
- ⌘ Ensure configuration PC and RM-240 are setup to communicate on the same network
- ⌘ Set dipswitch to SETUP
- ⌘ Power up unit, and wait for LINK led to cease flashing.
- ⌘ Adjust PC network settings

Set Configuration PC network card with network setting of IP address 192.168.0.1, net-mask 255.255.255.0

- ⌘ Open configuration webpage with Internet Explorer at address <http://192.168.0.1XX/>
When prompted for password, enter default username "user" and password "user"
Enter "Network", and select Operating Mode as Access Point.

Device Mode should be set to Router.

Set the Gateway IP address to 192.168.0.1

Set the Ethernet IP address to 192.168.0.200, network mask 255.255.255.0

Set the Wireless IP address to 169.254.102.54, network mask 255.255.255.0

Select the Radio Encryption required, and enter encryption keys if necessary.

Set dipswitch to RUN.

Click on button Save to Flash and Reset. Webpage will display that message indicating details are being written to flash. Wait for RM-240 to reboot before removing power.

Enter a System Generator String

Client Configuration

Perform the same configuration steps as the Access Point configuration with the following differences:

Enter “Network”, and select Operating Mode as Client.

Device Mode should be set to Bridge.

Set the Gateway IP address to 192.168.102.54

Set the Ethernet IP address to 192.168.102.53, network mask 255.255.255.0

Set the Wireless IP address to 169.254.102.53, network mask 255.255.255.0

Click on button Save to Flash and Reset. Webpage will display that message indicating details are being written to flash. Wait for RM-240 to reboot before removing power.

Extending range of a network with a Repeater hop

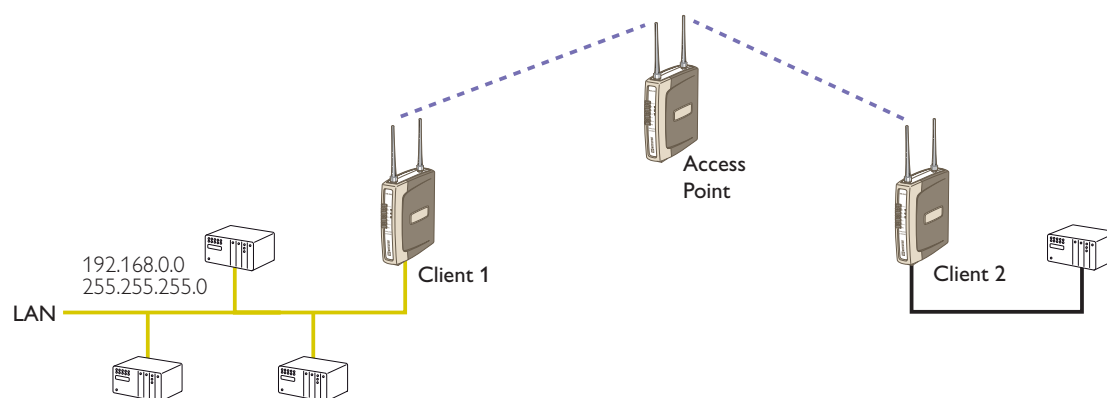

Configure units as described in Section *Extending a wired network*. Place the Access Point at the remote intermediate repeater location. Additional repeaters can be added using Wireless Distribution System (WDS) – refer section 3.10 Repeater Configuration for further details.

4.1 Diagnostics Chart

LED Indicator	Condition	Meaning
OK	GREEN	Normal Operation
OK	RED	Supply voltage too low.
Radio RX	GREEN flash	Radio receiving data
Radio TX	Flash	Radio Transmitting
Radio LINK	On	On when a radio communications link is established
Radio LINK	Off	Communications failure or radio link not established
LAN	ON	Link Established on Ethernet port
LAN	Flash	Activity on Ethernet port.
Serial	GREEN flash	Rs232 Serial Port Activity
Serial	RED flash	Rs485 Serial Port Activity
DIO	On	Digital Output ON or Input is grounded.
DIO	Off	Digital Output OFF and Input is open circuit.

The green OK LED on the front panel indicates correct operation of the unit. This LED turns red on failure as described above. When the OK LED turns red shutdown state is indicated. On processor failure, or on failure during startup diagnostics, the unit shuts down, and remains in shutdown until the fault is rectified.

Boot Loader LED Indication during Startup

Serial	LAN	LINK	ACTIVE	Comment
Orange	Orange	Orange	RED	Initial Power Up & bootload Initialisation
RED	Orange	Orange	RED	Check Config & Print Sign-on message (If boot delay not zero)
Orange	Orange	Orange	RED	Print Configuration Table to terminal (If boot delay not zero)
Green	LAN	Off	RED	Initialise Networking and Start Auto Boot sequence
Orange	LAN	Off	GREEN	Wait for <ENTER> to abort Auto boot (If boot delay not zero)
Sequence	LAN	Sequence	GREEN	Boot – loader active (auto boot aborted or no application)
SERIAL	LAN	LINK	GREEN	Normal Operation. Application Running.

4.2 Diagnostic Information Available

4.2.1 Connectivity

The Connectivity webpage at an Access Point lists all Clients with which it is associated. The page also indicates whether the encryption scheme has been authorized at the Access Point. A RM-240 will fail to be authorized if the encryption keys are incorrect. The received signal strength, background noise, and radio data rate is listed for each Client or Access Point by their MAC Address. The readings shown are based upon the last received data message from the Access Point or Client. Generating radio traffic to the device will update values for signal strength, background noise and radio data rate. Use programs such as Ping to generate data packets to test the radio path.

4.2.2 Monitor Communications

To monitor radio communications, it is necessary to configure the Operating Mode under “Network” as MONITOR. When in the MONITOR mode, the “Monitor Communications” function displays a continuous list of transmissions that are being received.

As Beacon messages occur very frequently, they have been filtered out from the Monitor Communications display for convenience.

Monitor communications lists the frame type of each transmission and various statistics of each transmission, along with a timestamp. Communications can only be monitored on one channel at a time – the channel that is used for monitoring can be altered on the radio settings page.

Use of this feature together with the Connectivity webpage will reveal the variability of communications over a link, and other systems that may be in the area.

4.2.3 Statistics

The Statistics webpage is used for advanced debugging of RM-240. The webpage details the state of the RM-240 and its performance in the system.

4.2.4 Network Traffic Analysis

There are many devices and PC programs that will analyse performance of an Ethernet network. Freely available programs such as Ethereal provide a simple cost effective means for more advanced analysis. By monitoring traffic on the wired Ethernet, a better idea of regular traffic can be discovered.

Network Analysis programs make configuration of a filter for the RM-240 a simple task.

4.3 Testing Radio Paths

The general procedure for radio range testing a link is fairly simple. Configure two units to form a link using automatic radio rates. Install the Access Point at a fixed location. Take a laptop computer and the Client to each of the remote locations, and analyse the link using the Connectivity webpage. If a beacon is heard from the Access Point, the Client will update its Connectivity webpage with the received signal strength of beacon messages from the Access Point.

If the signal is strong enough, a link may be established, and the Connectivity webpage of the Access Point may be opened. If the link is weak, the LINK led will go out, and the remote Connectivity webpage of the Access Point will fail to load. Using this procedure, the signal strengths of units at both locations may be analysed, and traffic is sent between the units whilst remote WebPages are opened.

4.4 Utilities

4.4.1 PING

Ping is a basic Internet program that lets you verify that a particular IP address exists and can accept requests. Ping is used diagnostically to ensure that a host computer you are trying to reach is actually operating. If, for example, a user can't ping a host, then the user will be unable to send files to that host. Ping operates by sending a packet to a designated address and waiting for a response. The basic operation of Ping can be performed by following these steps in any Windows operating system.

Click on the Start Menu and select Run. Type in "cmd" and enter, you should then see the command screen come up. There will be a certain directory specified (unique to your own PC) with a flashing cursor at the end. At the cursor type the word "ping" leaving a space and the default IP address for the RM-240 at first startup.

This command would be written as Ping 192.168.123.123 then Enter to send the ping command. The PC will reply with an acknowledgement of your command if your RM-240 is correctly configured.

It is also possible to use the "ping 192.168.123.123 -t" command.

This -t command is used to repeatedly ping the specified node in the network, to cancel use "Ctrl - C"

A good test for the network once it is first set up is to use PING repeatedly from one PC's IP address to the other PC's IP address. This gives a good example of the networks reliability and how responsive it is from point to point. When you enter "Ctrl C" the program reports a packet sent-received-lost percentage.

4.4.2 IPCONFIG

IPCONFIG can be used to show your current TCP/IP information, including your address, DNS server addresses, adapter type and so on.

In the above example ipconfig was entered in the command prompt. The reply back shows the PC's IP address, Subnet mask and the gateway it is connected to.

Other ipconfig commands will return back more information. The hardware or MAC address of the computer may be discovered using the command ipconfig /all.

Ipconfig /? will list all of the commands and their usages available for use.

4.4.3 ARP

Displays and modifies the IP-to-Physical address translation tables used by Address Resolution Protocol (ARP).

Once a remote computer has been pinged, this can be used to see the IP address & MAC address of the remote computer. It will also show any other devices on the network that it may be connected to.

The command used is Arp -a. It shows the PC's direct IP address of 192.168.0.17 as also shown before with IPCONFIG command. The other IP address shown with its associated MAC address is another device with a connection to the PC. In this example it is the IP address of a PLC connected to the PC also.

Arp -n lists all the commands available for this function.

4.4.4 ROUTE

Route is used for the Router function. This is where you are joining 2 different networks together via the RM-240 refer to Section 1.1

The RM-240 can only accept 1 Routing table. That is it can only accept one router per network of radios. On the Router radio network PC a routing rule needs to be entered to allow access between Network A and Network B. This is entered in the command prompt as per all other instructions above.

Route PRINT will show all active routes on PC,

Route ADD will add a routing table to network,

route DELETE <destination netmask gateway interface> will delete the unwanted routing table

route CHANGE modifies an existing route.

An example of a routing table is shown for the configuration below,

Network A Settings	Client Bridge Settings
IP Address 192.168.0.17	Gateway IP 192.168.2.51
Subnet Mask 255.255.255.0	Ethernet IP 192.168.2.50
Gateway IP 192.168.0.1	Subnet Mask 255.255.255.0 Wireless IP 192.168.2.50 Subnet Mask 255.255.255.0
Access Point Router Settings	Network B Settings
Gateway IP 192.168.0.1	IP Address 192.168.2.201
Ethernet IP 192.168.0.191	Subnet Mask 255.255.255.0
Subnet Mask 255.255.255.0	Gateway IP 192.168.2.51 Wireless IP 192.168.2.051 Subnet Mask 255.255.255.0

In the Network A PC a routing rule is to be set.

This will allow Network A & B to have access to each other. This is entered under cmd prompt.

Route ADD 192.168.2.0 MASK 255.255.255.0 192.168.0.191

This says access everything on network B (192.168.2.0) with the Mask of 255.255.255.0 on Network A via the Ethernet IP Interface 192.168.0.191

IP Address 192.168.2.0 will allow everything on this network to be shared by the router. When adding a routing table you will need to enter this in. Once entered in the Router will determine whether to pass information over the router if it is addressed to do so or not. For added security MAC address filtering could be added as mentioned earlier in Section 3.

General		
EMC specification	EN 300 683	FCC Part 90
Radio specification	EN 300 328	FCC Part 15.247, RSS 210
Housing	114 x 140 x 30mm 4.5 x 5.5 x 1.2 inch	Plastic housing DIN rail mount
Terminal blocks	Removable	Suitable for 12 gauge (2.5sqmm) conductors
LED indication	Active, Serial RX and TX, Radio RX and TX, Link	
Operating Temperature	-35 to +65 degrees C -30 to +150 degrees F	0 – 99% RH non-condensing
Power Supply		
Nominal supply	9 to 30VDC	Overvoltage and reverse voltage protected
Average current drain	240 mA @ 12V	150mA @ 24VDC
Ethernet Port		
Standard	10/100 BaseT	RJ45
	IEEE 802.3 compliant	Bridge/router, Access point/ client functionality
Radio Transceiver		
Transmit power	Different models available.	100mW (20dBm) or 300mW (25dBm)
Channels	11 x 5MHz	First channel centre at 2.412 GHz
Receiver sensitivity	< 8% FER	-96dBm @ 1Mb/s, -91dBm @ 11Mb/s
Antenna Connector	Female SMA coaxial	Two connectors for signal diversity
Wireless data rate – configurable	1 to 11Mb/s	“Auto” function determines fastest rate within user-configured fade-margin
Serial Ports		
RS232 Port	DB9 female DCE	RTS/CTS/DTR/DCD hardware signals provided
RS485 Port	2 pin terminal block	Max distance 4000' / 1.2 km
Data rate (bit/s) – configurable	1200, 2400, 4800, 9600, 14400, 19200, 38400, 57600, 76800, 115200	7 or 8 data bits, Stop/start/parity bits configurable
System Parameters		
System address	1 to 31 character text string	
Wireless data encryption	None, WEP (64bit and 128bit), WPA PSK (TKIP)	
User Configuration	Via embedded web page	Via RS232 commands, or RS 232 PPP connection
Diagnostics	LED's	OK, DCD, Radio and Serial RX/TX
	RSSI measurement in dBm	BER test

1. Ensure your PC network settings have a Subnet Mask of 255.255.255.0. This can be easily checked using DOS command IPCONFIG.
2. Extract FlashUpdate program, and start the program.
3. If prompted by firewall, select Unblock so that FlashUpdate program may operate.
4. Copy new firmware files to a known location on the hard drive of your PC. Do not unzip these files.
5. Specify location of firmware bootloader file (epm_mrb_Westermo_E24g_x.x.bin.gz) and firmware application file (epm_E24g_x.x.bin.gz) using the Browse buttons in the FlashUpdate program.
6. Connect PC to RM-240 RS-232 serial port with “straight-through” serial cable.
7. Select COM port connected to RM-240 in the *FlashUpdate* program.
8. Connect PC to RM-240 Ethernet port with “straight-through” Ethernet cable. This will usually be a blue color.
9. Switch dip-switch on RM-240 to SETUP mode.
10. Click on *Upgrade* button in FlashUpdate program.
11. Click OK.
12. Power up RM-240, or cycle power to RM-240, within 30 seconds of completing the previous step.
13. Programming will commence.
14. If programming was successful, a dialog box is displayed showing this.

ACK	Acknowledgment.
Access point	An access point is the connection that ties wireless communication devices into a network. Also known as a base station, the access point is usually connected to a wired network.
Antenna Gain	Antennae don't increase the transmission power, but focus the signal more. So instead of transmitting in every direction (including the sky and ground) antenna focus the signal usually either more horizontally or in one particular direction. This gain is measured in decibels
Bandwidth	The amount of "transportation" space an Internet user has at any given time.
Collision avoidance	A network node characteristic for proactively detecting that it can transmit a signal without risking a collision.
Crossover cable	A special cable used for networking two computers without the use of a hub. Crossover cables may also be required for connecting a cable or DSL modem to a wireless gateway or access point. Instead of the signals transferring in parallel paths from one set of plugs to another, the signals "crossover." If an eight-wire cable was being used, for instance, the signal would start on pin one at one end of the cable and end up on pin eight at the other end. They "cross-over" from one side to the other.
CSMA/CA	CSMA/CA is a "listen before talk" method of minimizing (but not eliminating) collisions caused by simultaneous transmission by multiple radios. IEEE 802.11 states collision avoidance method rather than collision detection must be used, because the standard employs half duplex radios (radios capable of transmission or reception) but not both simultaneously. Unlike conventional wired Ethernet nodes, a WLAN station cannot detect a collision while transmitting. If a collision occurs, the transmitting station will not receive an ACKnowledge packet from the intended receive station. For this reason, ACK packets have a higher priority than all other network traffic. After completion of a data transmission, the receive station will begin transmission of the ACK packet before any other node can begin transmitting a new data packet. All other stations must wait a longer pseudo randomized period of time before transmitting. If an ACK packet is not received, the transmitting station will wait for a subsequent opportunity to retry transmission.

CSMA/CD	A method of managing traffic and reducing noise on an Ethernet network. A network device transmits data after detecting that a channel is available. However, if two devices transmit data simultaneously, the sending devices detect a collision and retransmit after a random time delay.
DHCP	A utility that enables a server to dynamically assign IP addresses from a predefined list and limit their time of use so that they can be reassigned. Without DHCP, an IT Manager would have to manually enter in all the IP addresses of all the computers on the network. When DHCP is used, whenever a computer logs onto the network, it automatically gets an IP address assigned to it.
Dial-up	A communication connection via the standard telephone network, or Plain Old Telephone Service (POTS).
DNS	A program that translates URLs to IP addresses by accessing a database maintained on a collection of Internet servers. The program works behind the scenes to facilitate surfing the Web with alpha versus numeric addresses. A DNS server converts a name like mywebsite.com to a series of numbers like 107.22.55.26. Every website has its own specific IP address on the Internet.
DSL	Various technology protocols for high-speed data, voice and video transmission over ordinary twisted-pair copper POTS (Plain Old Telephone Service) telephone wires.
Encryption key	An alphanumeric (letters and/or numbers) series that enables data to be encrypted and then decrypted so it can be safely shared among members of a network. WEP uses an encryption key that automatically encrypts outgoing wireless data. On the receiving side, the same encryption key enables the computer to automatically decrypt the information so it can be read.
Firewall	Keeps unauthorized users out of a private network. Everything entering or leaving a system's internal network passes through the firewall and must meet the system's security standards in order to be transmitted. Often used to keep unauthorized people from using systems connected to the Internet.
Hub	A multiport device used to connect PCs to a network via Ethernet cabling or via WiFi. Wired hubs can have numerous ports and can transmit data at speeds ranging from 10 Mbit/s to multigigabyte speeds per second. A hub transmits packets it receives to all the connected ports. A small wired hub may only connect 4 computers; a large hub can connect 48 or more.

HZ	The international unit for measuring frequency, equivalent to the older unit of cycles per second. One megahertz (MHz) is one million hertz. One gigahertz (GHz) is one billion hertz. The standard US electrical power frequency is 60 Hz, the AM broadcast radio frequency band is 535 – 1605 kHz, the FM broadcast radio frequency band is 88 – 108 MHz, and wireless 802.11b LANs operate at 2.4 GHz.
IEEE	Institute of Electrical and Electronics Engineers, New York, www.ieee.org . A membership organization that includes engineers, scientists and students in electronics and allied fields. It has more than 300,000 members and is involved with setting standards for computers and communications.
Infrastructure mode	A client setting providing connectivity to an AP. As compared to Ad-Hoc mode, whereby PCs communicate directly with each other, clients set in Infrastructure Mode all pass data through a central AP. The AP not only mediates wireless network traffic in the immediate neighborhood, but also provides communication with the wired network. See Ad-Hoc and AP.
I/O	The term used to describe any operation, program or device that transfers data to or from a computer.
Internet appliance	A computer that is intended primarily for Internet access, is simple to set up and usually does not support installation of third-party software. These computers generally offer customized web browsing, touch-screen navigation, e-mail services, entertainment and personal information management applications.
IP	A set of rules used to send and receive messages at the Internet address level.
IP (Internet Protocol) telephony	Technology that supports voice, data and video transmission via IP-based LANs, WANs, and the Internet. This includes VoIP (Voice over IP).
IP address	A 32-bit number that identifies each sender or receiver of information that is sent across the Internet. An IP address has two parts: an identifier of a particular network on the Internet and an identifier of the particular device (which can be a server or a workstation) within that network.

IPX-SPX	IPX, short for Internetwork Packet Exchange, a networking protocol used by the Novell NetWare operating systems. Like UDP/IP, IPX is a datagram protocol used for connectionless communications. Higher-level protocols, such as SPX and NCP, are used for additional error recovery services. Sequenced Packet Exchange, SPX, a transport layer protocol (layer 4 of the OSI Model) used in Novell Netware networks. The SPX layer sits on top of the IPX layer (layer 3) and provides connection-oriented services between two nodes on the network. SPX is used primarily by client/server applications.
ISA	A type of internal computer bus that allows the addition of card-based components like modems and network adapters. ISA has been replaced by PCI and is not very common anymore.
ISDN	A type of broadband Internet connection that provides digital service from the customer's premises to the dial-up telephone network. ISDN uses standard POTS copper wiring to deliver voice, data or video.
ISO Network Model	A network model developed by the International Standards Organization (ISO) that consists of seven different levels, or layers. By standardizing these layers, and the interfaces in between, different portions of a given protocol can be modified or changed as technologies advance or systems requirements are altered. The seven layers are: Physical, Data Link, Network, Transport, Session, Presentation, Application.
LAN	A system of connecting PCs and other devices within the same physical proximity for sharing resources such as an Internet connections, printers, files and drives.
Receive Sensitivity	The minimum signal strength required to pick up a signal. Higher bandwidth connections have less receive sensitivity than lower bandwidth connections.
Router	A device that forwards data from one WLAN or wired local area network to another.
SNR	Signal to Noise Ratio. The number of decibels difference between the signal strength and background noise.
Transmit Power	The power usually expressed in mW or db that the wireless device transmits at.

MAC Address	A MAC address, short for Media Access Control address, is a unique code assigned to most forms of networking hardware. The address is permanently assigned to the hardware, so limiting a wireless network's access to hardware (such as wireless cards) is a security feature employed by closed wireless networks. But an experienced hacker (armed with the proper tools) can still figure out an authorized MAC address, masquerade as a legitimate address and access a closed network. Every wireless 802.11 device has its own specific MAC address hard-coded into it. This unique identifier can be used to provide security for wireless networks. When a network uses a MAC table, only the 802.11 radios that have had their MAC addresses added to that network's MAC table will be able to get onto the network.
NAT	Network Address Translation: A network capability that enables a houseful of computers to dynamically share a single incoming IP address from a dial-up, cable or xDSL connection. NAT takes the single incoming IP address and creates new IP address for each client computer on the network.
NIC	A type of PC adapter card that either works without wires (Wi-Fi) or attaches to a network cable to provide two-way communication between the computer and network devices such as a hub or switch. Most office wired NICs operate at 10 Mbit/s (Ethernet), 100 Mbit/s (Fast Ethernet) or 10/100 Mbit/s dual speed. High-speed Gigabit and 10 Gigabit NIC cards are also available. See PC Card.
Proxy server	Used in larger companies and organizations to improve network operations and security, a proxy server is able to prevent direct communication between two or more networks. The proxy server forwards allowable data requests to remote servers and/or responds to data requests directly from stored remote server data.
RJ-45	Standard connectors used in Ethernet networks. Even though they look very similar to standard RJ-11 telephone connectors, RJ-45 connectors can have up to eight wires, whereas telephone connectors have only four.
Server	A computer that provides its resources to other computers and devices on a network. These include print servers, Internet servers and data servers. A server can also be combined with a hub or router.
Site survey	The process whereby a wireless network installer inspects a location prior to putting in a wireless network. Site surveys are used to identify the radio- and client-use properties of a facility so that access points can be optimally placed.

SSL	Commonly used encryption scheme used by many online retail and banking sites to protect the financial integrity of transactions. When an SSL session begins, the server sends its public key to the browser. The browser then sends a randomly generated secret key back to the server in order to have a secret key exchange for that session
Subnetwork or Subnet	Found in larger networks, these smaller networks are used to simplify addressing between numerous computers. Subnets connect to the central network through a router, hub or gateway. Each individual wireless LAN will probably use the same subnet for all the local computers it talks to.
Switch	A type of hub that efficiently controls the way multiple devices use the same network so that each can operate at optimal performance. A switch acts as a networks traffic cop: rather than transmitting all the packets it receives to all ports as a hub does, a switch transmits packets to only the receiving port.
TCP	A protocol used along with the Internet Protocol (IP) to send data in the form of individual units (called packets) between computers over the Internet. While IP takes care of handling the actual delivery of the data, TCP takes care of keeping track of the packets that a message is divided into for efficient routing through the Internet. For example, when a web page is downloaded from a web server, the TCP program layer in that server divides the file into packets, numbers the packets, and then forwards them individually to the IP program layer. Although each packet has the same destination IP address, it may get routed differently through the network. At the other end, TCP reassembles the individual packets and waits until they have all arrived to forward them as a single file.
TCP/IP	The underlying technology behind the Internet and communications between computers in a network. The first part, TCP, is the transport part, which matches the size of the messages on either end and guarantees that the correct message has been received. The IP part is the user's computer address on a network. Every computer in a TCP/IP network has its own IP address that is either dynamically assigned at startup or permanently assigned. All TCP/IP messages contain the address of the destination network as well as the address of the destination station. This enables TCP/IP messages to be transmitted to multiple networks (subnets) within an organization or worldwide.
VoIP	Voice transmission using Internet Protocol to create digital packets distributed over the Internet. VoIP can be less expensive than voice transmission using standard analog packets over POTS (Plain Old Telephone Service).

VPN	A type of technology designed to increase the security of information transferred over the Internet. VPN can work with either wired or wireless networks, as well as with dial-up connections over POTS. VPN creates a private encrypted tunnel from the end user's computer, through the local wireless network, through the Internet, all the way to the corporate servers and database.
WAN	A communication system of connecting PCs and other computing devices across a large local, regional, national or international geographic area. Also used to distinguish between phone-based data networks and Wi-Fi. Phone networks are considered WANs and Wi-Fi networks are considered Wireless Local Area Networks (WLANs).
WEP	Basic wireless security provided by Wi-Fi. In some instances, WEP may be all a home or small-business user needs to protect wireless data. WEP is available in 40-bit (also called 64-bit), or in 108-bit (also called 128-bit) encryption modes. As 108-bit encryption provides a longer algorithm that takes longer to decode, it can provide better security than basic 40-bit (64-bit) encryption.
Wi-Fi	Wireless Fidelity: An interoperability certification for wireless local area network (LAN) products based on the Institute of Electrical and Electronics Engineers (IEEE) 802.11 standard.



Westermo Teleindustri AB • SE-640 40 Stora Sundby, Sweden

Phone +46 16 42 80 00 Fax +46 16 42 80 01

E-mail: info@westermo.se

Westermo Web site: www.westermo.com

Subsidiaries

Westermo Data Communications AB

SE-640 40 Stora Sundby
Phone: +46 (0)16 42 80 00
Fax: +46 (0)16 42 80 01
E-mail: info@westermo.se

Westermo OnTime AS

Gladsvei 20 0489 Oslo, Norway
Phone +47 22 09 03 03 • Fax +47 22 09 03 10
E-mail: contact@ontimenet.com

Westermo Data Communications Ltd

Talisman Business Centre • Duncan Road
Park Gate, Southampton • SO31 7GA
Phone: +44(0)1489 580-585 • Fax: +44(0)1489 580586
E-Mail: sales@westermo.co.uk

Westermo Data Communications GmbH

Goethestraße 67, 68753 Waghäusel
Tel.: +49(0)7254-95400-0 • Fax: +49(0)7254-95400-9
E-Mail: info@westermo.de

Westermo Data Communications S.A.R.L.

9 Chemin de Chilly 91160 CHAMPLAN
Tél : +33 1 69 10 21 00 • Fax : +33 1 69 10 21 01
E-mail : infos@westermo.fr

Westermo Teleindustri AB have distributors in several countries, contact us for further information.