

User Guide
6650-2211

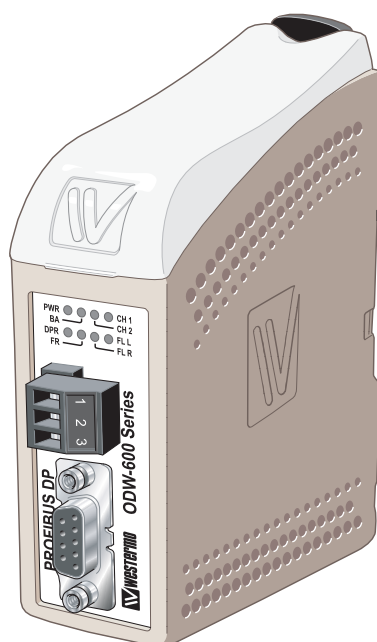

ODW-612

Fibre Optic Modem



Industrial Converter
PROFIBUS DP to
Fibre Optic Link.
Repeater, line and redundant ring

www.westermo.com

Legal information

The contents of this document are provided “as is”. Except as required by applicable law, no warranties of any kind, either express or implied, including, but not limited to, the implied warranties of merchantability and fitness for a particular purpose, are made in relation to the accuracy and reliability or contents of this document. Westermo reserves the right to revise this document or withdraw it at any time without prior notice.

Under no circumstances shall Westermo be responsible for any loss of data or income or any special, incidental, and consequential or indirect damages howsoever caused.

More information about Westermo can be found at the following Internet address:

<http://www.westermo.com>

Safety



Before installation:

Read this manual completely and gather all information on the unit. Make sure that you understand it fully. Check that your application does not exceed the safe operating specifications for this unit.

This unit should only be installed by qualified personnel.

This unit should be built-in to an apparatus cabinet, or similar, where access is restricted to service personnel only.

The power supply wiring must be sufficiently fused, and if necessary it must be possible to disconnect manually from the power supply. Ensure compliance to national installation regulations.

This unit uses convection cooling. To avoid obstructing the airflow around the unit, follow the spacing recommendations (see Cooling section).



Before mounting, using or removing this unit:

Prevent access to hazardous voltages by disconnecting the unit from the power supply.

Warning! Do not open a connected unit. Hazardous voltages may occur within this unit when connected to a power supply.



Class 1 Laser Product

This unit is designed to meet the Class 1 Laser regulations. However, the user is warned not to look directly into fibre optical fibre port or any connected fibre.

Care recommendations

Follow the care recommendations below to maintain full operation of the unit and to fulfil the warranty obligations.

This unit must not be operated with covers or lids removed.

Do not attempt to disassemble the unit. There are no user serviceable parts inside.

Do not drop, knock or shake the unit. Rough handling beyond the specification may cause damage to internal circuit boards.

Do not use harsh chemicals, cleaning solvents or strong detergents to clean the unit.

Do not paint the unit. Paint can clog the unit and prevent proper operation.

Do not expose the unit to any kind of liquids (rain, beverages, etc).

The unit is not waterproof. Keep the unit within the specified humidity levels.

Do not use or store the unit in dusty, dirty areas. Connectors as well as other mechanical parts may be damaged.

If the unit is not working properly, contact the place of purchase, nearest Westermo distributor office, or Westermo Tech support.

Fibre connectors are supplied with plugs to avoid contamination inside the optical port.

The plug should be fitted when no optical fibre is inserted in the connector, e.g. during storage, service or transportation.

Note. Fibre Optic Handling

Fibre optic equipment requires careful handling as the fibre components are very sensitive to dust and dirt. If the fibre is disconnected from the modem, the protective plug on the transmitter/receiver must be replaced. The protective plug must be kept on during transportation. The fibre optic cable must also be protected in the same way. If this recommendation is not followed, it can jeopardise the warranty.

Cleaning of the optical connectors

In the event of contamination, the optical connectors should be cleaned by using forced nitrogen and some kind of cleaning stick.

Recommended cleaning fluids:

- Methyl-, ethyl-, isopropyl- or isobutyl-alcohol
- Hexane
- Naphtha

Maintenance

No maintenance is required, as long as the unit is used as intended within the specified conditions.

Agency approvals and standards compliance

Type	Approval / Compliance
EMC	EN 61000-6-2, Immunity industrial environments
	EN 55024, Immunity IT equipment
	EN 61000-6-3, Emission residential environments
	FCC part 15 Class A
	EN 50121-4, Railway signalling and telecommunications apparatus
	IEC 62236-4, Railway signalling and telecommunications apparatus
Safety	EN 60950-1, IT equipment

NOTE: This equipment has been tested and found to comply with the limits for a Class A digital device, pursuant to Part 15 of the FCC Rules. These limits are designed to provide reasonable protection against harmful interference when the equipment is operated in a commercial environment. This equipment generates, uses, and can radiate radio frequency energy and, if not installed and used in accordance with the instruction manual, may cause harmful interference to radio communications. Operation of this equipment in a residential area is likely to cause harmful interference in which case the user will be required to correct the interference at his own expense.

Declaration of Conformity



Westermo Teleindustri AB

Declaration of conformity

The manufacturer Westermo Teleindustri AB
SE-640 40 Stora Sundby, Sweden

Herewith declares that the product(s)

Type of product	Model	Art no	Installation manual
Industrial Converter, PROFIBUS DP to fibre optic link	ODW-611	3650-0001, 3650-0010 3650-0020, 3650-0030	6650-2201
	ODW-612	3650-0501, 3650-0510 3650-0520, 3650-0530	6650-2211
Industrial Converter, RS-232 to fibre optic link	ODW-621	3650-0101, 3650-0110 3650-0120, 3650-0130	6650-2221
	ODW-622	3650-0601, 3650-0610 3650-0620, 3650-0630	6650-2231
Industrial Converter, RS-485 to fibre optic link	ODW-631	3650-0201, 3650-0210 3650-0220, 3650-0230	6650-2221
	ODW-632	3650-0701, 3650-0710 3650-0720, 3650-0730	6650-2231

is in conformity with the following EC directive(s).

No	Short name
89/336/EEG	Electromagnetic Compatibility (EMC)

References of standards applied for this EC declaration of conformity.

No	Title	Issue
EN 61000-6-2	Immunity for industrial environments	2 (2001)
EN 55024	Information technology equipment – Immunity	1 (1998)
EN 61000-6-3	Emission standard for residential, commercial and light-industrial environments	1 (2001)

Herewith declares that product(s) listed above is in conformity with

No	Title	Issue
FCC part 15	Radio frequency devices	2003

Hans Levin
Technical Manager
15th March 2006

Postaddress/Postal address
S-640 40 Stora Sundby
Sweden

Tel.
016-428000
Int+46 16428000

Telefax
016-428001
Int+46 16428001

Postgiro
52 72 79-4

Bankgiro
5671-5550

Org.nr/
Corp. identity number
556361-2604

Registered office
Eskilstuna

Type tests and environmental conditions

Electromagnetic Compatibility			
Phenomena	Test	Description	Level
ESD	EN 61000-4-2	Enclosure contact	± 6 kV
		Enclosure air	± 8 kV
RF field AM modulated	IEC 61000-4-3	Enclosure	20 V/m 80% AM (1 kHz), 80 – 2000 MHz
RF field 900 MHz	ENV 50204	Enclosure	20 V/m pulse modulated 200 Hz, 900 ± 5 MHz
Fast transient	EN 61000-4-4	Signal ports	± 2 kV
		Power ports	± 2 kV
Surge	EN 61000-4-5	Signal ports unbalanced	± 2 kV line to earth, ± 2 kV line to line
		Signal ports balanced	± 2 kV line to earth, ± 1 kV line to line
		Power ports	± 2 kV line to earth, ± 2 kV line to line
RF conducted	EN 61000-4-6	Signal ports	10 V 80% AM (1 kHz), 0.15 – 80 MHz
		Power ports	10 V 80% AM (1 kHz), 0.15 – 80 MHz
Power frequency magnetic field	EN 61000-4-8	Enclosure	100 A/m, 50 Hz, 16.7 Hz & 0 Hz
Pulse Magnetic field	EN 61000-4-9	Enclosure	300 A/m, 6.4 / 16 µs pulse
Voltage dips and interruption	EN 61000-4-11	AC power ports	10 & 5 000 ms, interruption 10 & 500 ms, 30% reduction 100 & 1 000 ms, 60% reduction
Mains freq. 50 Hz	EN 61000-4-16	Signal ports	100 V 50 Hz line to earth
Mains freq. 50 Hz	SS 436 15 03	Signal ports	250 V 50 Hz line to line
Voltage dips and interruption	EN 61000-4-29	DC power ports	10 & 100 ms, interruption 10 ms, 30% reduction 10 ms, 60% reduction +20% above & –20% below rated voltage
Radiated emission	EN 55022	Enclosure	Class B
	FCC part 15		Class A
Conducted emission	EN 55022	AC power ports	Class B
	FCC part 15	AC power ports	Class A
	EN 55022	DC power ports	Class B
Dielectric strength	EN 60950	Signal port to all other isolated ports	2 kVrms 50 Hz 1min
		Power port to other isolated ports	3 kVrms 50 Hz 1min 2 kVrms 50 Hz 1min (@ rated power < 60V)
Environmental			
Temperature		Operating	–40 to +60°C
		Storage & Transport	–40 to +70°C
Humidity		Operating	5 to 95% relative humidity
		Storage & Transport	5 to 95% relative humidity
Altitude		Operating	2 000 m / 70 kPa
Service life		Operating	10 year
Vibration	IEC 60068-2-6	Operating	7.5 mm, 5 – 8 Hz 2 g, 8 – 500 Hz
Shock	IEC 60068-2-27	Operating	15 g, 11 ms
Packaging			
Enclosure	UL 94	PC / ABS	Flammability class V-1
Dimension W x H x D			35 x 121 x 119 mm
Weight			0.26 kg
Degree of protection			IP 21
Cooling	IEC 529	Enclosure	Convection
Mounting			Horizontal on 35 mm DIN-rail

Description

Introduction

The ODW-612 is a fibre optic modem for Redundant ring and multidrop applications. It acts as a repeater between the two fibre optic links, and as a converter between fibre optical links and the electrical PROFIBUS DP.

The maximum distance of the fibre link depends on selected transceiver and fibre type. Distance up to 80 km (50 miles). ODW-612 is designed for harsh out-door usage, in industrial, road or railway installations.

The PROFIBUS DP data rate is set automatically as soon as ODW-612 has identified a correct data frame. Retiming ensures the correct PROFIBUS DP signal format.

- ⌘ 9-position D-sub PROFIBUS DP connector
- ⌘ Data rate up to 12 Mbit/s
- ⌘ Automatic data rate detection and retiming
- ⌘ Redundant ring alternatively multidrop communication via fibre optical network
- ⌘ Small Form Factor Pluggable (SFP) transceivers
- ⌘ LC-2 Multimode LC connectors, 5 km (3.1 miles)
- ⌘ LC-15 Singlemode LC connectors, 15 km (9.3 miles)
- ⌘ LC-40 Singlemode LC connectors, 40 km (24.9 miles)
- ⌘ LC-80 Singlemode LC connectors, 80 km (50 miles)
- ⌘ Redundant power supply, 2 kVAC galvanic isolated to other ports
- ⌘ Status interface for fault indication
- ⌘ Designed for harsh environments

Functional description

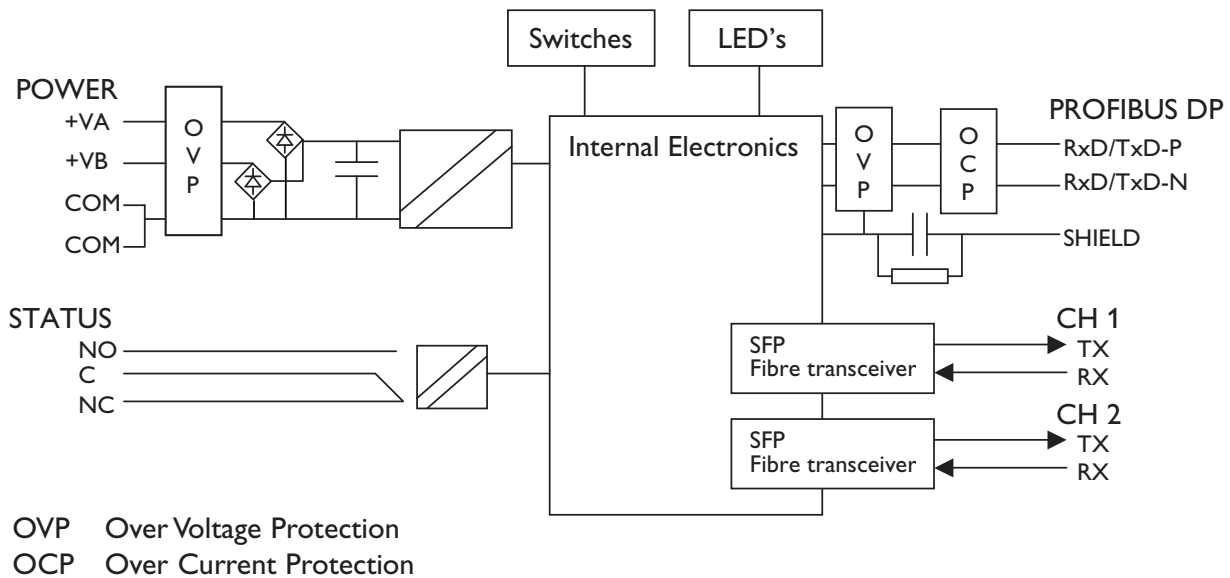

Converter PROFIBUS DP – optical fibre

ODW-612 is a fibre optic modem that converts between electrical PROFIBUS DP and a fibre optical link.

Repeater – optical fibre links

ODW-612 is a fibre optic repeater that repeats received data from one fibre link out to the other link. This is useful e.g. for long distance communication, where electromagnetic interference may occur or when isolation of the electrical network is needed. The maximum optical fibre distance depends on selected fibre transceiver and fibre type. Distances up to 80 km (50 miles) are available.

Data rate up to 12 Mbit/s

ODW-612 converts PROFIBUS DP data using data rates from 9 600 bit/s up to 12 Mbit/s. Retiming of the PROFIBUS DP data ensures that the correct signal form is transmitted from the ODW-612 converter.

Automatic data rate detection

The PROFIBUS data rate is set automatically as soon as the ODW-612 receives a correct data frame, whether data is received from PROFIBUS DP or the fibre optical link. The detected data rate remains until a number of consecutive faulty received frames have been detected or no further frames are detected within the timeout period. The timeout period is set by switches, with the default setting of one faulty frame or $65\,535\ t_{bit}$ without any received frame.

Redundant ring via fibre optical network

Under normal operation the PROFIBUS DP data is sent over ring A. Should a fault be detected on the fibre ring then the PROFIBUS DP data will be carried on rings A and B.

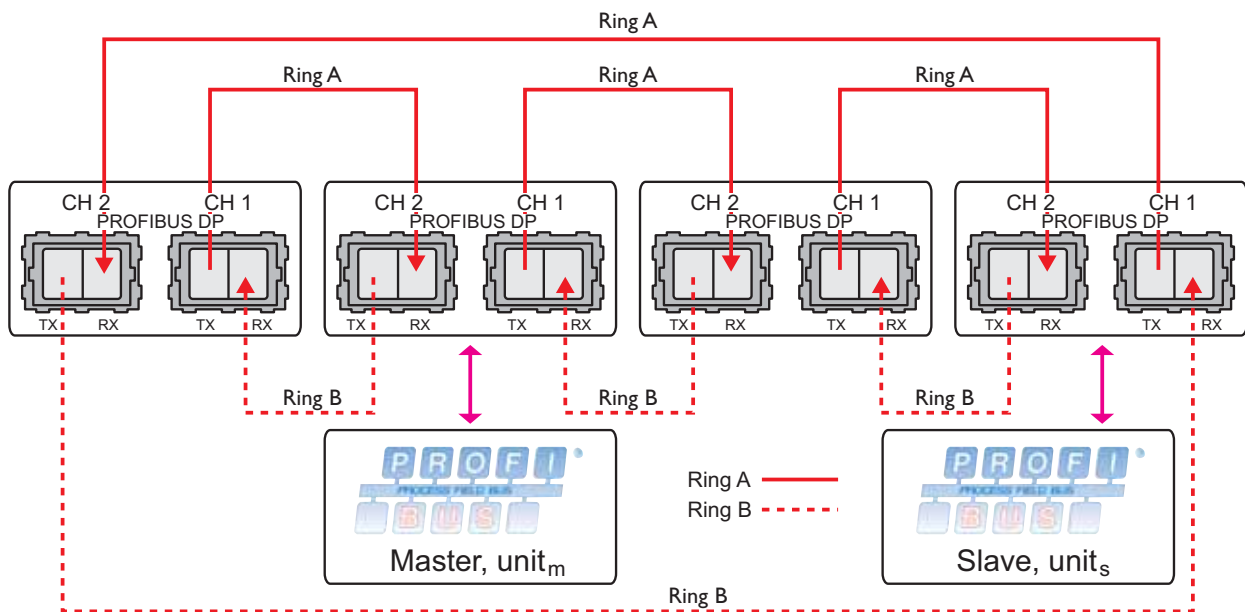

Note! Ring A start up at TX (channel 1) and ring B ends up at RX (channel 1).

- ⊞ Normal operation, data exchange between PROFIBUS DP master and slave.
 - Unit_M receives PROFIBUS DP data (from a Master) at the electrical port, it converts and transfers this master frame via the fibre ring A.
At unit_M, the repeating of transferred frames is stopped until this transferred master frame has returned to unit_M via ring A.
 - This master frame will be repeated through fibre ring A by all the other units. Each of these units will also convert the master frame to PROFIBUS DP data and send it via the electrical port.
 - Unit_S, to which the addressed Slave is connected, receives PROFIBUS DP data from the Slave. Unit_S converts slave data and transfers the slave frame via ring A.
The repeating of transferred frames is stopped until this transferred slave frame has returned via ring A.
 - When unit_M receives the master frame (the same frame that has been transmitted by this unit), or after a timeout, data conversion at unit_M will be allowed again.
The received slave frame will be converted and transmitted at the electrical port.
 - When unit_S receives the slave frame (the same frame that has been transmitted by this unit), or after a timeout, data conversion at unit_S will be allowed again.
- ⊞ Behaviour under faulty conditions
 - Elapsed time from any kind of failure at the fibre optic network until data exchange after a corrective action depends on total length of fibre ring.
This is typically 10–20 ms. During that time, the transferred data frames should be seen as corrupted or missed.

Failure	Corrective action	Indications
Fibre interruption ring A, TX	Switch to ring B	On: FL R
Fibre interruption ring A, RX	Switch to ring B	On: FL L
Fibre interruption ring A, RX & TX	Switch to ring B	On FL L
Fibre interruption ring B, TX	–	On: FL R
Fibre interruption ring B, RX	–	On: FL L
Fibre interruption ring B, RX & TX	–	On: FL L
Fibre interruption ring A and B (e.g. CH1 or CH2 both TX & RX)	Switch to multidrop application*	On: FL L &/or FL R
Low power on the receiver (May indicate bad fibre)		FLL flicker

* Regarding functionality see chapter “multidrop application”

Recovery from faulty status

- ODW-612 will automatically recover to the previous operating status when a failure disappears. This involves recovery from multidrop application to Redundant ring A/B when ring is up and running and recovery from Ring B to Redundant ring A when the ring is up and running.
- The time to recover from the failure status depends on total length of fibre ring. This is typically 10–20 ms. During that time the transferred data frames should be seen as corrupted or missed.

Multidrop via fibre optical network

The electrical PROFIBUS DP network is transferred via the fibre optic network to the electrical ports of all units. If ODW-612 is connected to two optical fibre links (mid unit) converted data will be transmitted in both directions, via both CH 1 and CH 2. With only one optical fibre link (end unit) converted data will be transmitted in one direction, via CH 1 only. Data received from one ODW-612 optical fibre port will be repeated through the other optical fibre port and it will also convert the frame to PROFIBUS DP data and send it via the electrical port.

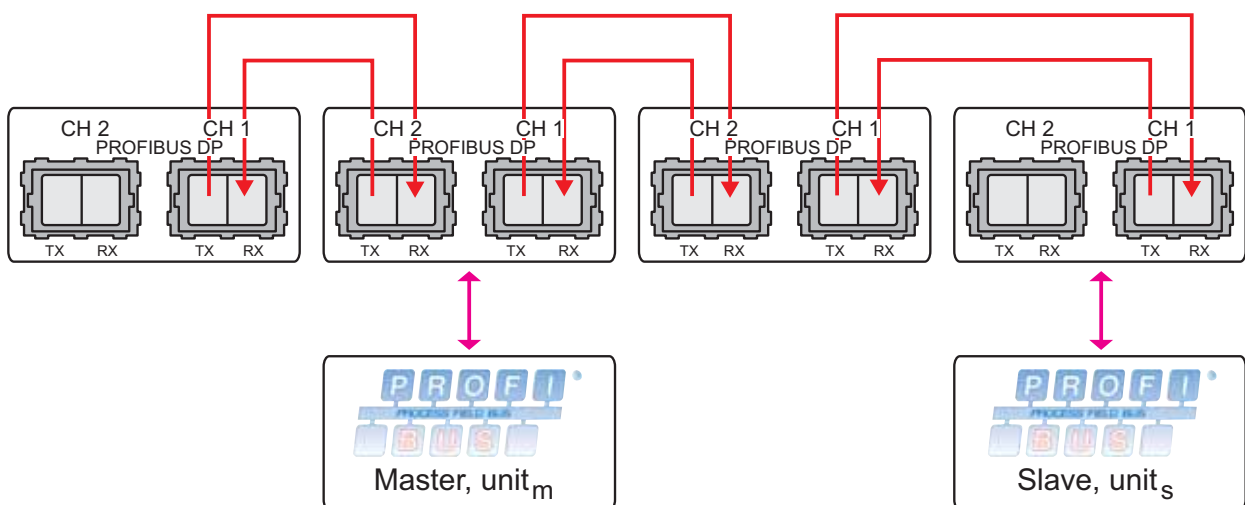

Optical fibre link functionality and status indication

At power on, all LED's will be active during an initiation sequence followed by an automatic initiation of the optical fibre links. The alarm will be set until the fibre optical links are in operation and ready to transfer PROFIBUS DP data.

Data frames are transferred over the fibre optic links as long as the links are in operation and the data rate has been detected.

When any of the fibre optic links is out of operation, this will be indicated by a local alarm, and this will set the alarm output. It will also send a remote alarm via the other link, if possible. When the link returns to operations mode, the alarm will reset automatically.

The Bus active (BA) LED is set if data frames are received on the electrical PROFIBUS DP or fibre optical port and the data rate is detected, independently of the status on fibre optical link.

Redundant power supply, galvanic isolated (2 kVAC) to other ports

ODW-612 should be supplied with safety extra low voltage (SELV). It is designed to operate permanently over a wide input range and provided with two independent inputs, allowing redundancy should either supply fail.

9-position D-sub PROFIBUS DP connector

The pin assignment for the connector is in compliance with PROFIBUS standard EN 50 170

Single or multimode LC fibre connectors

ODW-612 use Small Form Factor Pluggable (SFP) transceivers that are in compliance with the Multi-Sourcing Agreement (MSA). This means that a wide range of different fibre transceivers and connectors can be used.

Status interface

This interface enables supervision of fibre optic link state by means of a relay with both normally open and closed contacts.

The fault state will be set if:

- ⚡ Local or remote fibre link errors exist.
- ⚡ The unit is out of service, e.g. no power supply.

Designed for harsh environments, such as industrial, road and railway applications

ODW-612 complies with standards for industrial environments and railway signalling and telecommunications apparatus. Additionally, the wide climatic range of the ODW-612 allows it to be installed in out-door cabinets without any additional measures, such as heating, etc.

System delay in an optical network

Data exchange between a PROFIBUS DP master and slave via ODW-612 fibre optic link, will be delayed due to the length of the optical fibre and the signal processing within the ODW-612. The signal processing delay is dependent on the data rate, and the fibre delay is dependent on the total length of the optical fibre.

There is no limitation of the total length of optical fibre for Multi-drop applications. In Redundant ring applications the data transfer time in a ring is limited to 10 milliseconds. This means the total length of the optical fibre ring is about 2 000 km, excluding the 1 microsecond delay at each optical repeater unit.

The additional time resulting from the optical fibre and ODW-612 is the Overall system delay. The Redundant ring and Multidrop application Overall system delays differ, see below.

	Delay @ < 1.5 Mbit/s	Delay @ 3 to 12 Mbit/s
Optical fibre length delay (typical)	5 µs/km	5 µs/km
Signal processing, electrical to fibre (max)	1 t_{bit} + 1.0 µs	9 t_{bit} + 1.0 µs
Signal processing, fibre to electrical (max)	0.3 µs	0.3 µs

Note $t_{bit} = 1 / \text{Baud rate}$ (Baud rate in bit/s)

⚡ Redundant ring, one data exchange.

- The data exchange between PROFIBUS DP master and slave via ODW-612 fibre optic link will run one direction through all units of the ring. The system delay is calculated by summing the following:
 - 1. Fibre:** The total optical fibre ring length delay.
 - 2. Optical repeaters:** The optical repeater delay x Number of optical repeaters (excluding the ODW-612 units connected to PROFIBUS DP master and addressed slave).
 - 3. Converter electrical to fibre:** Signal processing delay x 2 (ODW-612 units connected to PROFIBUS DP master and addressed slave).
 - 4. Converter fibre to electrical:** Signal processing delay x 2 (ODW-612 units connected to PROFIBUS DP master and addressed slave).

Multidrop, one data exchange.

- The data exchange between PROFIBUS DP master and slave via ODW-612 fibre optic link will run from the ODW-600 units connected to PROFIBUS DP master to the slave and the same way back to the master. The system delay is calculated by summing the following:
 - 1. Fibre:** The optical fibre length PROFIBUS DP master to addressed slave delay $\times 2$.
 - 2. Optical repeaters:** The optical repeater delay \times Number of optical repeaters (excluding the ODW-612 units connected to PROFIBUS DP master and addressed slave) $\times 2$.
 - 3. Converter electrical to fibre:** Signal processing delay $\times 2$ (ODW-612 units connected to PROFIBUS DP master and addressed slave).
 - 4. Converter fibre to electrical:** Signal processing delay $\times 2$ (ODW-612 units connected to PROFIBUS DP master and addressed slave).

Example

- Redundant ring, one data exchange between master and one slave. One PROFIBUS DP master and 11 slaves with data rate 1.5 Mbit/s. 12 ODW-612 units with a total fibre length of 40 km. A data exchange between master and one slave.
 - 1. Fibre:** The total optical fibre ring length delay.
 $40 \times 5 \mu\text{s} = 200 \mu\text{s}$
 - 2. Optical repeaters:** The optical repeater delay \times Number of optical repeaters (excluding the ODW-612 units connected to PROFIBUS DP master and addressed slave).
 $(12 - 2) \times 1 \mu\text{s} = 10 \mu\text{s}$
 - 3. Converter electrical to fibre:** Signal processing delay $\times 2$ (ODW-612 units connected to PROFIBUS DP master and addressed slave).
 $(1 t_{\text{Bit}} + 1.0 \mu\text{s}) \times 2 = (0.7 \mu\text{s} + 1.0 \mu\text{s}) \times 2 = 3.4 \mu\text{s}$
 - 4. Converter fibre to electrical:** Signal processing delay $\times 2$ (ODW-612 units connected to PROFIBUS DP master and addressed slave).
 $0.3 \mu\text{s} \times 2 = 0.6 \mu\text{s}$
 - 5. The system delay is calculated by summing the delays in item 1 to 4 above:**
 $200 \mu\text{s} + 10 \mu\text{s} + 3.4 \mu\text{s} + 0.6 \mu\text{s} = 216 \mu\text{s}$

Interface specifications

Power	
Rated voltage	12 to 48 VDC 24 VAC
Operating voltage	10 to 60 VDC 20 to 30 VAC
Rated current	400 mA @ 12 VDC 200 mA @ 24 VDC 100 mA @ 48 VDC
Rated frequency	DC
Inrush current I ² t	0.2 A ² s
Startup current*	1.0 A _{peak}
Polarity	Reverse polarity protected
Redundant power input	Yes
Isolation to	PROFIBUS DP and Status port
Connection	Detachable screw terminal
Connector size	0.2 – 2.5 mm ² (AWG 24 – 12)
Shielded cable	Not required

* External supply current capability for proper startup

Status	
Port type	Signal relay, changeover contacts
Rated voltage	Up to 48 VDC
Operating voltage	Up to 60 VDC
Contact rating	500 mA @ 48 VDC
Contact resistance	< 50 mΩ
Isolation to	PROFIBUS DP and Power port
Connection	Detachable screw terminal
Connector size	0.2 – 2.5 mm ² (AWG 24 – 12)

FX (Fibre)	SM-LC80	SM-LC40	SM-LC15	MM-LC2
Fibre connector	LC duplex	LC duplex	LC duplex	LC duplex
Fibre type	Singlemode 9/125 µm	Singlemode 9/125 µm	Singlemode 9/125 µm	Multimode 62.5/125 and 50/125 µm
Wavelength	1550 nm	1310 nm	1310 nm	1310 nm
Transmitter Output optical power min/max	-5/0 dBm **	-5/0 dBm **	-15/-8 dBm **	-20/-14 dBm *
Receiver Input sensitivity	-34 dBm (max)	-34 dBm (max)	-31 dBm (max)	-31 dBm (max)
Receiver Input optical power Maximum	-5 dBm (min) ***	-3 dBm (min) ***	-8 dBm (min)	-8 dBm (min)
Optical power budget, worst case	29 dB	29 dB	16 dB	1 dB
Bit error rate (BER)	<1 x 10 ⁻¹⁰	<1 x 10 ⁻¹⁰	<1 x 10 ⁻¹⁰	<2.5 x 10 ⁻¹⁰
Transceiver type	Small Form Factor Pluggable (SFP) Multi-Sourcing Agreement (MSA) compliant			
Laser class	Class 1, IEC 825-1 Accessible Emission Limit (AEL)			

* Output power is power coupled into a 62.5/125 µm multimode fibre.

** Output power is power coupled into a 9/125 µm singlemode fibre.

*** The optical power should be reduced by at least 5 dB (SM-LC80) or 3dB (SM-LC40) between the optical output and input.

Optical Power Budget

The maximum supported link lengths as specified in the table above should only be seen as indicative. The allowed link length is calculated from the Optical Power Budget (OPB), (the available optical power for a fibre-optic link), and the attenuation of the fibre, comprising losses due to in-line connectors, splices, optical switches and a margin for link aging (typical 1.5 dB for 1300 nm).

The worst-case Optical Power Budget (OPB) in dB for a fibre-optic link is determined by the difference between the minimum transmitter output optical power and the lowest receiver sensitivity.



PROFIBUS DP (RS-485)	
Electrical specification	EIA RS-485 / EN 50 170
Data rate	9 600 bit/s, 19.2, 93.75, 187.5, 500 kbit/s, 1.5, 3, 6 and 12 Mbit/s
Data format	8 data bits, even parity, 1 stop bit, 11 bits total
Protocol	PROFIBUS DP / EN 50170
Data Rate detection	Yes, compliant with EN 50 170
Retiming	Yes
Turn around time	In accordance with EN 50 170
Transmission range	≤ 1200 m, depending on data rate and cable type (EIA RS-485)
Settings	None, external termination and failsafe biasing
Protection	Installation Fault Tolerant (up to ±60 V)
Isolation to	Power and Status port
Connection	9-pin D-sub female
Shielded cable	Not required
Conductive housing	Isolated to all other circuits and housings

Connections

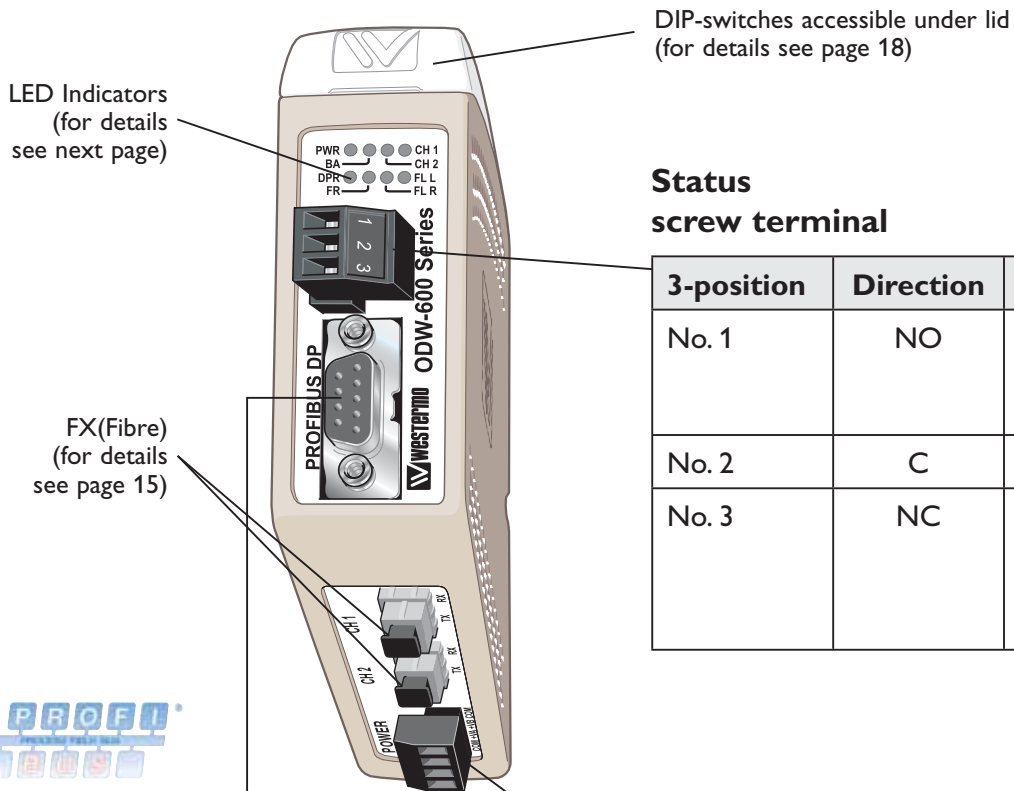

Status screw terminal

3-position	Direction	Description
No. 1	NO	Contact with C when link is in operation
No. 2	C	Common
No. 3	NC	Open (no contact with C) when fibre link is in operation



PROFIBUS DP (RS-485) D-sub

9-position	Direction	Description
No. 1	–	–
No. 2	–	–
No. 3	In/Out	RxD/TxD-P
No. 4	Out	CNTR-P
No. 5	–	DGND
No. 6	Out	VP
No. 7	–	–
No. 8	In/Out	RxD/TxD-N

Power screw terminal

4-position marking	Description
No. 1	–Voltage
No. 2	+Voltage A
No. 3	+Voltage B

LED Indicators

LED	Status	Description
PWR Power	ON	In service (power).
	Flashing	Fault condition.
	OFF	Out of service.
BA Bus active	ON	PROFIBUS DP in operation. Received data frame with detected data rate on the electrical PROFIBUS DP or optical fibre port.
	OFF	Data frame with detected data rate has not been received, or received frames have been interrupted during a time, or a number of consecutive faulty frames*.
CH 2 Channel	ON	Fibre link at port CH 2 in operation. Data can be transmitted.
	OFF	Fibre link at port CH 2 out of operation.
CH 1 Channel	ON	Fibre link at port CH 1 in operation. Data can be transmitted.
	OFF	Fibre link at port CH 1 out of operation.
DPR Receive PROFIBUS DP	Flash	Receive data on the electrical PROFIBUS DP port. Data will be transmitted to the fibre link, if it is a correct PROFIBUS DP frame.
	OFF	–
FR Receive fibre link	Flash	Receive data on the Fibre Link. This frame is transmitted to the PROFIBUS DP channel.
	OFF	–
FL R Failure link remote	ON	Remote Fibre Link failure. A fibre link is out of operation at any other unit of the optical network.
	OFF	All fibre links are in operation at all other units in the fibre optical network.
FL L Failure link local	ON	Local fibre link failure. This unit has identified a fibre link failure.
	OFF	Fibre link of this unit is in operation

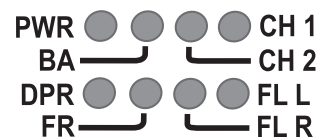

* Time and number of frames are set by DIP-switch S:2.

DIP-switch settings



Before setting DIP-switches:

Prevent damage to internal electronics from electrostatic discharges (ESD) by discharging your body to a grounding point (e.g. use of wrist strap).

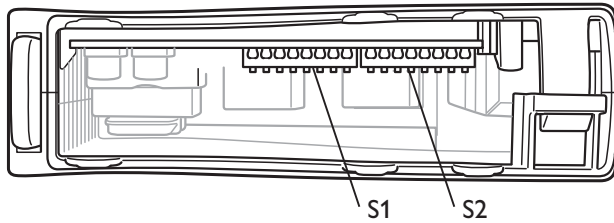

S1 DIP-switch



Set status port at local fibre link error

S2 DIP-switch



Multidrop, end unit application. One optical fibre port, CH 1



5 seconds interruption in receiving frames, until inactive BA*



Multidrop application, mid unit. Both optical fibre ports, CH 1 & CH 2



10 seconds interruption in receiving frames, until inactive BA*



Redundant ring application



20 seconds interruption in receiving frames, until inactive BA*



65535 t_{bit} interruption in receiving frames, until inactive BA*











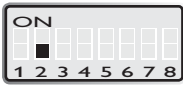

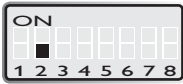



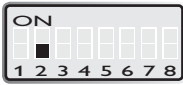

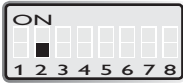

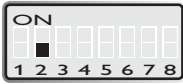
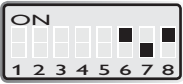
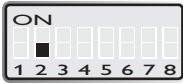

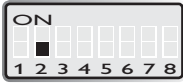
* Delay since last correct received frame until PROFIBUS DP is out of operation. (BA LED inactive)

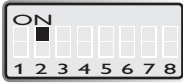
$t_{bit} = 1 / \text{Baud rate. (Baud rate in bit/s)}$

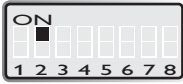
Factory settings

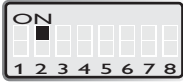

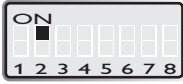
Faulty frame before data rate is seen as unidentified

S1 DIP-switch	S2 DIP-switch	Description
		1 faulty frame before data rate is seen as unidentified. S1: No extended retry limit.
		2 faulty frame before data rate is seen as unidentified. S1: No extended retry limit.
		3 faulty frame before data rate is seen as unidentified. S1: No extended retry limit.
		4 faulty frame before data rate is seen as unidentified. S1: No extended retry limit.
		5 faulty frame before data rate is seen as unidentified. S1: No extended retry limit.
		6 faulty frame before data rate is seen as unidentified. S1: No extended retry limit.
		7 faulty frame before data rate is seen as unidentified. S1: No extended retry limit.
		8 faulty frame before data rate is seen as unidentified. S1: No extended retry limit.
		31 faulty frame before data rate is seen as unidentified. S1: Extended retry limit.
		63 faulty frame before data rate is seen as unidentified. S1: Extended retry limit.
		127 faulty frame before data rate is seen as unidentified. S1: Extended retry limit.
		255 faulty frame before data rate is seen as unidentified. S1: Extended retry limit.

Mounting

This unit should be mounted on 35 mm DIN-rail, which is horizontally mounted inside an apparatus cabinet, or similar. Snap on mounting, see figure.

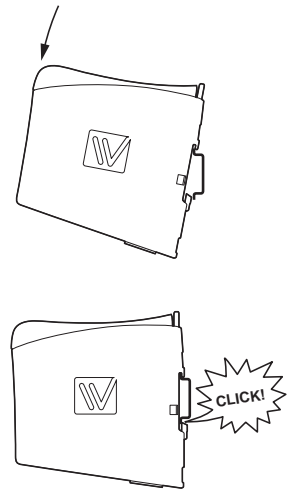

Cooling

This unit uses convection cooling. To avoid obstructing the air-flow around the unit, use the following spacing rules. Minimum spacing 25 mm (1.0 inch) above /below and 10 mm (0.4 inches) left /right the unit. Spacing is recommended for the use of unit in full operating temperature range and service life.

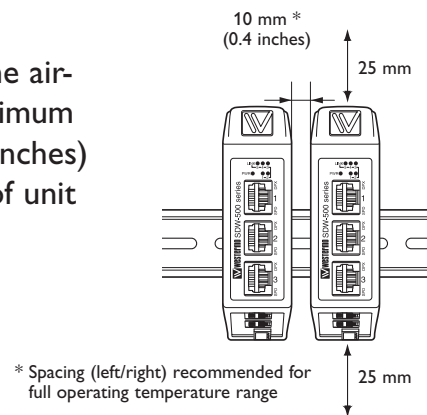

Removal

Press down the black support at the top of the unit. See figure.

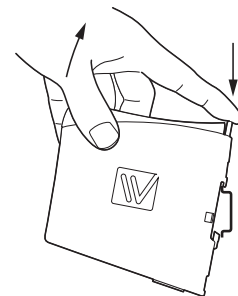

Start up guide

Redundant ring application

Follow the steps below to get the unit up and running in a simple application.

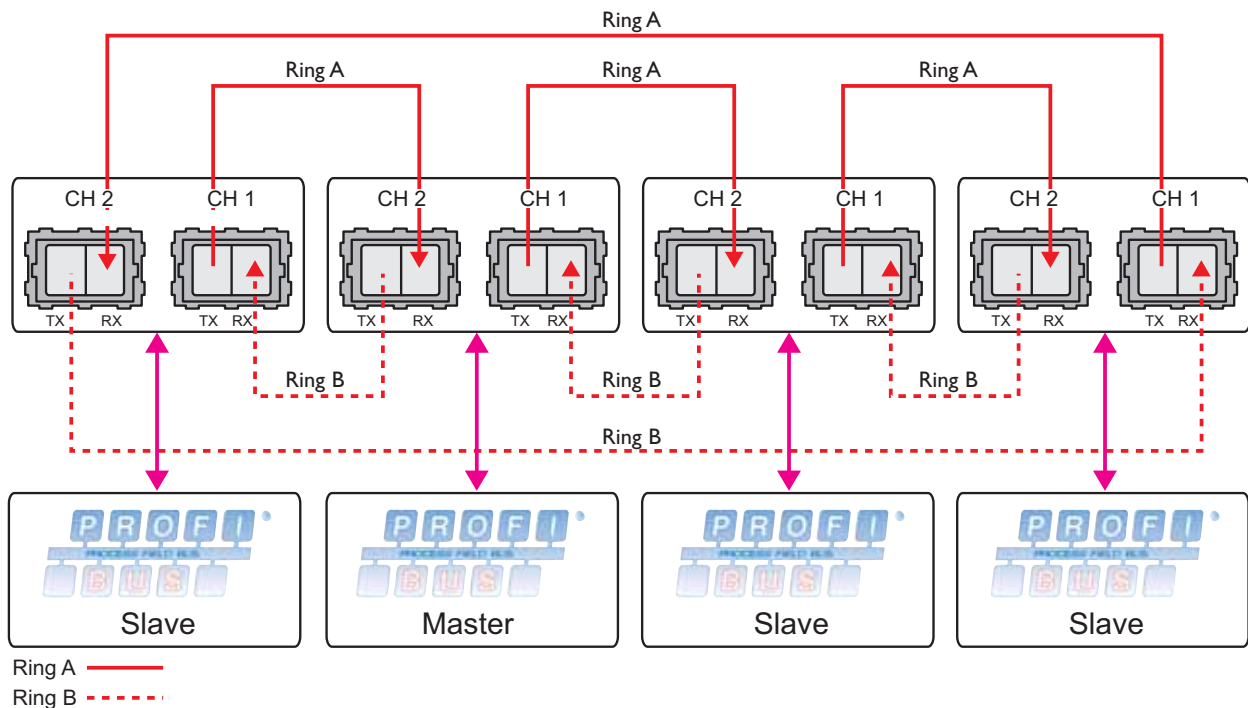

Prepare the PROFIBUS units

- ⌘ Configure PROFIBUS DP network, with master and slaves. Check that it is running correctly with the electrical PROFIBUS DP network.

Prepare the fibre optical network

- ⌘ Redundant ring. Set switch S2:3 set to ON and all others to OFF, at all units.
- ⌘ Connect the fibre links between the units.
- ⌘ Connect the power supply to all units.
 - The Fibre links should be in operation, indicated by active CH 1 and CH 2 LED's.
- ⌘ Connect each of the PROFIBUS DP slaves to PROFIBUS DP port of corresponding ODW-612.
- ⌘ Connect PROFIBUS DP master to PROFIBUS DP port of one ODW-612.
 - The PROFIBUS DP will be in operation and the data rate should have been identified, indicated by BA LED.
- ⌘ The Redundant ring application is up and running.

Multidrop application

Follow the steps below to get the unit up and running in a simple application.

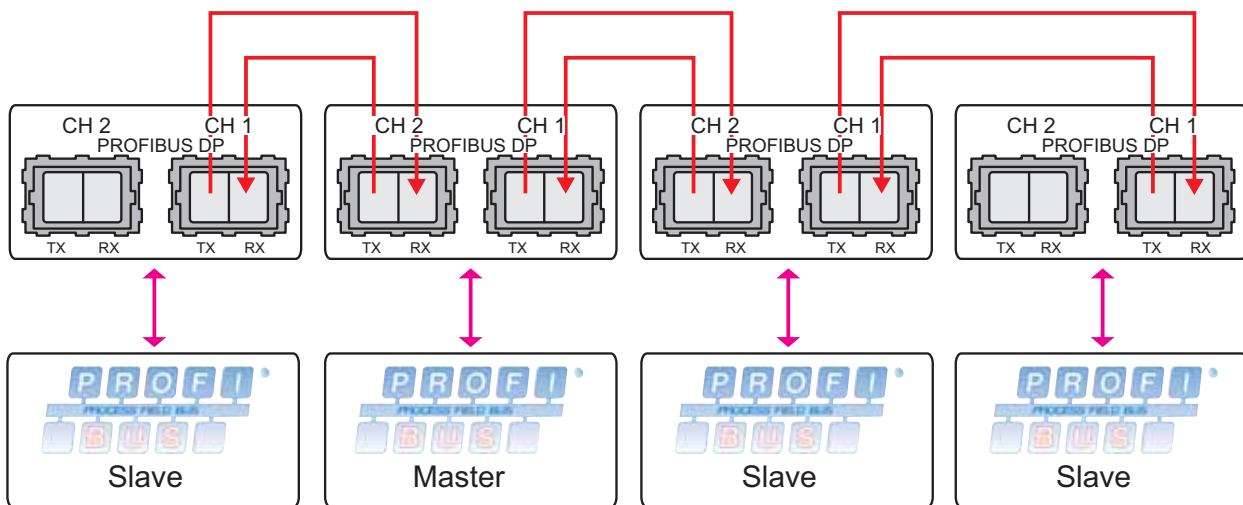

Prepare the PROFIBUS units

- ⌘ Configure PROFIBUS DP network, with master and slaves. Check that it is running correctly with the electrical PROFIBUS DP network.

Prepare the fibre optical network

- ⌘ Multidrop, mid units (CH 1 & CH 2). Set switch S2:2 set to ON and all others to OFF.
- ⌘ Multidrop, end units (CH 1 only). All switches should be set to OFF.
- ⌘ Connect the fibre links between the units.
- ⌘ Connect the power supply to all units.
 - The Fibre links should be in operation, indicated by active CH 1 and CH 2 LED's.
- ⌘ Connect each of the PROFIBUS DP slaves to the PROFIBUS DP port of the corresponding ODW-612.
- ⌘ Connect PROFIBUS DP master to the PROFIBUS DP port of one ODW-612
 - The PROFIBUS DP will be in operation and the data rate should have been identified, indicated by BA LED.
- ⌘ The Multidrop application is up and running.

Note! ODW-611 can be used as end units.

Hints

If the fibre distance is long it may be necessary to adjust the bus parameter Slot time, the monitoring time (t_{bit}) of the sender of frame for acknowledgement of recipient and the TSDR Station Delay of Responders, at configuration of the PROFIBUS DP master.

If the time between transferred PROFIBUS DP frames is long, it may be necessary to allow a longer time of interruption in receiving frames, using DIP-switches.

If disturbances in the electrical PROFIBUS DP network result in missed frames, it may be necessary to allow a number of consecutive faulty frames before the bus is considered to be out of operation, using DIP-switches.



Westermo Teleindustri AB • SE-640 40 Stora Sundby, Sweden
Phone +46 16 42 80 00 Fax +46 16 42 80 01
E-mail: info@westermo.se
Westermo Web site: www.westermo.com

Subsidiaries

Westermo Data Communications AB
SE-724 81 Västerås
Phone: +46 (0)16 42 80 00 • Fax: +46 (0)21 35 18 50
info.sverige@westermo.se

Westermo OnTime AS
Gladsvei 20 0489 Oslo, Norway
Phone +47 22 09 03 03 • Fax +47 22 09 03 10
E-mail: contact@ontimenet.com

Westermo Data Communications Ltd
Talisman Business Centre • Duncan Road
Park Gate, Southampton • SO31 7GA
Phone: +44(0)1489 580-585 • Fax: +44(0)1489 580586
E-Mail: sales@westermo.co.uk

Westermo Data Communications GmbH
Goethestraße 67, 68753 Waghäusel
Tel.: +49(0)7254-95400-0 • Fax: +49(0)7254-95400-9
E-Mail: info@westermo.de

Westermo Data Communications S.A.R.L.
9 Chemin de Chilly 91160 CHAMPLAN
Tél : +33 1 69 10 21 00 • Fax : +33 1 69 10 21 01
E-mail : infos@westermo.fr

Westermo Data Communications Pte Ltd
2 Soon Wing Road #08-05
Soon Wing Industrial Building
Singapore 347893
Phone +65 6743 9801 • Fax +65 6745 0670
E-mail: earnestphua@westermo.com.sg

Westermo Teleindustri AB have distributors in several countries, contact us for further information.