

User Guide  
6650-2201

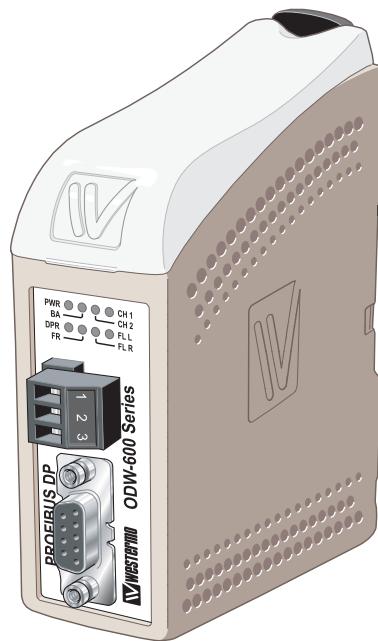

# ODW-611

Fibre Optic Modem



**Industrial Converter**  
**PROFIBUS DP to**  
**Fibre Optic Link.**  
**Point to Point applications**

[www.westermo.com](http://www.westermo.com)

## **Legal information**

The contents of this document are provided “as is”. Except as required by applicable law, no warranties of any kind, either express or implied, including, but not limited to, the implied warranties of merchantability and fitness for a particular purpose, are made in relation to the accuracy and reliability or contents of this document. Westermo reserves the right to revise this document or withdraw it at any time without prior notice.

Under no circumstances shall Westermo be responsible for any loss of data or income or any special, incidental, and consequential or indirect damages howsoever caused.

More information about Westermo can be found at the following Internet address:

**<http://www.westermo.com>**

## Safety



### **Before installation:**

Read this manual completely and gather all information on the unit. Make sure that you understand it fully. Check that your application does not exceed the safe operating specifications for this unit.

This unit should only be installed by qualified personnel.

This unit should be built-in to an apparatus cabinet, or similar, where access is restricted to service personnel only.

The power supply wiring must be sufficiently fused, and if necessary it must be possible to disconnect manually from the power supply. Ensure compliance to national installation regulations.

This unit uses convection cooling. To avoid obstructing the airflow around the unit, follow the spacing recommendations (see Cooling section).



### **Before mounting, using or removing this unit:**

Prevent access to hazardous voltage by disconnecting the unit from power supply. Warning! Do not open connected unit. Hazardous voltage may occur within this unit when connected to power supply.



### **Class 1 Laser Product**

Do not look directly into fibre optical fibre port or any connected fibre although this unit is designed to meet the Class 1 Laser regulations.

### **Care recommendations**

Follow the care recommendations below to maintain full operation of unit and to fulfil the warranty obligations.

This unit must not be operating with removed covers or lids.

Do not attempt to disassemble the unit. There are no user serviceable parts inside.

Do not drop, knock or shake the unit, rough handling above the specification may cause damage to internal circuit boards.

Do not use harsh chemicals, cleaning solvents or strong detergents to clean the unit.

Do not paint the unit. Paint can clog the unit and prevent proper operation.

Do not expose the unit to any kind of liquids (rain, beverages, etc). The unit is not waterproof. Keep the unit within the specified humidity levels.

Do not use or store the unit in dusty, dirty areas, connectors as well as other mechanical part may be damaged.

If the unit is not working properly, contact the place of purchase, nearest Westermo distributor office or Westermo Tech support.

Fibre connectors are supplied with plugs to avoid contamination inside the optical port.

As long as no optical fibre is mounted on the connector, e.g. for storage, service or transportation, should the plug be applied.

## Note. Fibre Optic Handling

Fibre optic equipment needs special treatment. It is very sensitive to dust and dirt. If the fibre will be disconnected from the modem the protective hood on the transmitter/receiver must be connected. The protective hood must be kept on during transportation. The fibre optic cable must also be handle the same way.

If this recommendation not will be followed It can jeopardise the warranty.

## Cleaning of the optical connectors

In the event of contamination, the optical connectors should be cleaned by the use of forced nitrogen and some kind of cleaning stick.

Recommended cleaning fluids:

- Methyl-, ethyl-, isopropyl- or isobutyl-alcohol
- Hexane
- Naphtha

## Maintenance

No maintenance is required, as long as the unit is used as intended within the specified conditions.

## Agency approvals and standards compliance

Type	Approval / Compliance
EMC	EN 61000-6-2, Immunity industrial environments
	EN 55024, Immunity IT equipment
	EN 61000-6-3, Emission residential environments
	FCC part 15 Class A
	EN 50121-4, Railway signalling and telecommunications apparatus
	IEC 62236-4, Railway signalling and telecommunications apparatus
Safety	EN 60950-1, IT equipment

**NOTE:** This equipment has been tested and found to comply with the limits for a Class A digital device, pursuant to Part 15 of the FCC Rules. These limits are designed to provide reasonable protection against harmful interference when the equipment is operated in a commercial environment. This equipment generates, uses, and can radiate radio frequency energy and, if not installed and used in accordance with the instruction manual, may cause harmful interference to radio communications. Operation of this equipment in a residential area is likely to cause harmful interference in which case the user will be required to correct the interference at his own expense.

# Declaration of Conformity



Westermo Teleindustri AB

## Declaration of conformity

The manufacturer Westermo Teleindustri AB  
SE-640 40 Stora Sundby, Sweden

Herewith declares that the product(s)

Type of product	Model	Art no	Installation manual
Industrial Converter, PROFIBUS DP to fibre optic link	ODW-611	3650-0001, 3650-0010 3650-0020, 3650-0030	6650-2201
	ODW-612	3650-0501, 3650-0510 3650-0520, 3650-0530	6650-2211
Industrial Converter, RS-232 to fibre optic link	ODW-621	3650-0101, 3650-0110 3650-0120, 3650-0130	6650-2221
	ODW-622	3650-0601, 3650-0610 3650-0620, 3650-0630	6650-2231
Industrial Converter, RS-485 to fibre optic link	ODW-631	3650-0201, 3650-0210 3650-0220, 3650-0230	6650-2221
	ODW-632	3650-0701, 3650-0710 3650-0720, 3650-0730	6650-2231

is in conformity with the following EC directive(s).

No	Short name
89/336/EEG	Electromagnetic Compatibility (EMC)

References of standards applied for this EC declaration of conformity.

No	Title	Issue
EN 61000-6-2	Immunity for industrial environments	2 (2001)
EN 55024	Information technology equipment – Immunity	1 (1998)
EN 61000-6-3	Emission standard for residential, commercial and light-industrial environments	1 (2001)

Herewith declares that product(s) listed above is in conformity with

No	Title	Issue
FCC part 15	Radio frequency devices	2003

Hans Levin  
Technical Manager  
15th March 2006

Postaddress/Postal address  
S-640 40 Stora Sundby  
Sweden

Tel.  
016-428000  
Int+46 16428000

Telefax  
016-428001  
Int+46 16428001

Postgiro  
52 72 79-4

Bankgiro  
5671-5550

Org.nr/  
Corp. identity number  
556361-2604

Registered office  
Eskilstuna

## Type tests and environmental conditions

<b>Electromagnetic Compatibility</b>			
<b>Phenomena</b>	<b>Test</b>	<b>Description</b>	<b>Level</b>
ESD	EN 61000-4-2	Enclosure contact	± 6 kV
		Enclosure air	± 8 kV
RF field AM modulated	IEC 61000-4-3	Enclosure	20 V/m 80% AM (1 kHz), 80 – 2000 MHz
RF field 900 MHz	ENV 50204	Enclosure	20 V/m pulse modulated 200 Hz, 900 ± 5 MHz
Fast transient	EN 61000-4-4	Signal ports	± 2 kV
		Power ports	± 2 kV
Surge	EN 61000-4-5	Signal ports unbalanced	± 2 kV line to earth, ± 2 kV line to line
		Signal ports balanced	± 2 kV line to earth, ± 1 kV line to line
		Power ports	± 2 kV line to earth, ± 2 kV line to line
RF conducted	EN 61000-4-6	Signal ports	10 V 80% AM (1 kHz), 0.15 – 80 MHz
		Power ports	10 V 80% AM (1 kHz), 0.15 – 80 MHz
Power frequency magnetic field	EN 61000-4-8	Enclosure	100 A/m, 50 Hz, 16.7 Hz & 0 Hz
Pulse Magnetic field	EN 61000-4-9	Enclosure	300 A/m, 6.4 / 16 µs pulse
Voltage dips and interruption	EN 61000-4-11	AC power ports	10 & 5 000 ms, interruption 10 & 500 ms, 30% reduction 100 & 1 000 ms, 60% reduction
Mains freq. 50 Hz	EN 61000-4-16	Signal ports	100 V 50 Hz line to earth
Mains freq. 50 Hz	SS 436 15 03	Signal ports	250 V 50 Hz line to line
Voltage dips and interruption	EN 61000-4-29	DC power ports	10 & 100 ms, interruption 10 ms, 30% reduction 10 ms, 60% reduction +20% above & -20% below rated voltage
Radiated emission	EN 55022	Enclosure	Class B
	FCC part 15		Class A
Conducted emission	EN 55022	AC power ports	Class B
	FCC part 15	AC power ports	Class A
	EN 55022	DC power ports	Class B
Dielectric strength	EN 60950	Signal port to all other isolated ports	2 kVrms 50 Hz 1min
		Power port to other isolated ports	3 kVrms 50 Hz 1min 2 kVrms 50 Hz 1min (@ rated power < 60V)
<b>Environmental</b>			
Temperature		Operating	-40 to +70°C
		Storage & Transport	-40 to +70°C
Humidity		Operating	5 to 95% relative humidity
		Storage & Transport	5 to 95% relative humidity
Altitude		Operating	2 000 m / 70 kPa
Service life		Operating	10 year
Vibration	IEC 60068-2-6	Operating	7.5 mm, 5 – 8 Hz 2 g, 8 – 500 Hz
Shock	IEC 60068-2-27	Operating	15 g, 11 ms
<b>Packaging</b>			
Enclosure	UL 94	PC / ABS	Flammability class V-1
Dimension W x H x D			35 x 121 x 119 mm
Weight			0.26 kg
Degree of protection			IP 21
Cooling	IEC 529	Enclosure	Convection
Mounting			Horizontal on 35 mm DIN-rail

# Description

## Introduction

The ODW-611 is a fibre optic modem for point to point applications, that converts between electrical PROFIBUS DP and fibre optical link.

The maximum distance of the fibre link depends on selected transceiver and fibre type. Distance up to 80 km (50 miles). ODW-611 is designed for harsh out-door usage, in industrial, road or railway installations.

The PROFIBUS data rate is set automatically as soon as ODW-611 has identified a correct data frame. Retiming ensures the correct PROFIBUS DP signal format.

- ⌘ 9-position D-sub PROFIBUS DP connector
- ⌘ Data rate up to 12 Mbit/s
- ⌘ Automatic data rate detection and retiming
- ⌘ Point to point communication via fibre optical network
- ⌘ Small Form Factor Pluggable (SFP) transceivers
- ⌘ LC-2 Multimode LC connectors, 5 km (3.1 miles)
- ⌘ LC-15 Singlemode LC connectors, 15 km (9.3 miles)
- ⌘ LC-40 Singlemode LC connectors, 40 km (24.9 miles)
- ⌘ LC-80 Singlemode LC connectors, 80 km (50 miles)
- ⌘ Bi-di Multimode LC connectors, 5 km (3.1 miles)
- ⌘ Bi-di Singlemode LC connectors, 40 km (24.9 miles)
- ⌘ Bi-di Singlemode LC connectors, 60 km (37.3 miles)
- ⌘ Designed for harsh environments
- ⌘ Redundant power supply, 2 kVac galvanic isolated to other ports
- ⌘ Status interface for fault indication

# Functional description

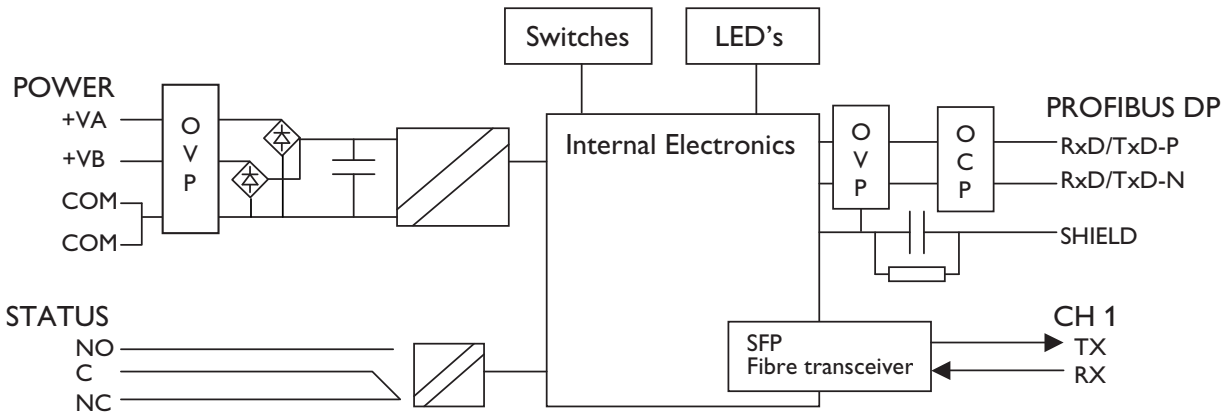

OVP Over Voltage Protection  
 OCP Over Current Protection

## Converter PROFIBUS DP – optical fibre

ODW-611 is a fibre optic modem that converts between electrical PROFIBUS DP and fibre optical link.

### Data rate up to 12 Mbit/s

ODW-611 converts PROFIBUS DP data in data rate from 9600 bit/s up to 12 Mbit/s. Retiming of the PROFIBUS DP data ensures that the correct signal format is transmitted from the ODW-611 converter.

### Automatic data rate detection

The PROFIBUS data rate is set automatically as soon as ODW-611 has identified a correct data frame, independently of whether data is received from PROFIBUS DP or the fibre optical link. Detected data rate remains until a number of consecutive faulty received frames or after a delay without any received frame. This is set by switches, with default setting of one faulty frame or  $65\ 535\ t_{Bit}$ .

### Point to point communication via fibre optical network

The electrical PROFIBUS DP network is transferred via a fibre optical network by the use of two ODW-611 units. This application is useful e.g. for long distance communication, where electromagnetic interferences may occur or when isolation of the electrical network is needed.

The maximum optical fibre distance depends on selected fibre transceiver and fibre type. Distance up to 80 km (50 miles).

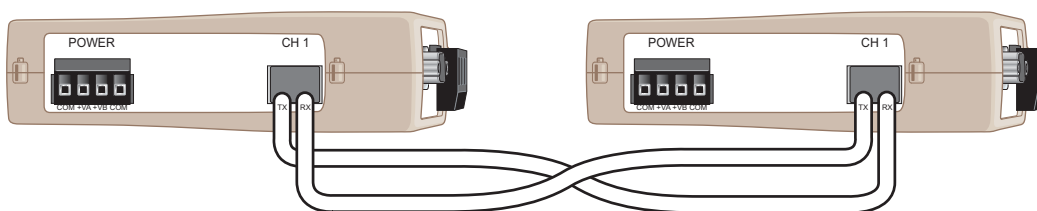

Fibre optical connection at point to point communication



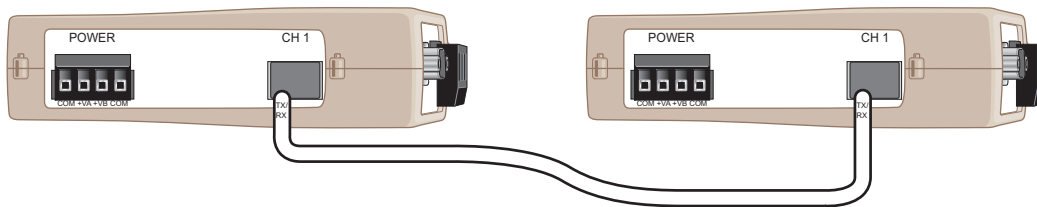

Fibre optical connection  
at point to point communication (Bi-di transceiver)



Bi-di transceiver, TX 1310 nm,  
RX 1550 nm.



Bi-di transceiver, TX 1550 nm,  
RX 1310 nm.

**Note! The bi-di transceivers must always be used in pair, see example:**

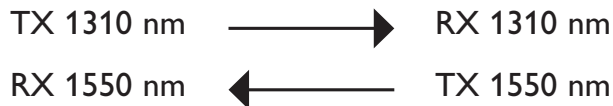

### Functionality and status indication

At power on, all LED's will be active during an initiation sequence followed by an automatic initiation of the optical fibre link. The alarm will be set until the fibre optical link is in operation and ready to transfer PROFIBUS DP data.

Data frames are transferred over the fibre optical link as long as the link is in operation and the data rate has been detected.

When the fibre optical link is out of operation, it will be indicated by a local alarm, and this will set the alarm output. When the link returns to operations mode, the alarm will rest automatically.

The Bus active (BA) LED is set if data frames are received on the electrical PROFIBUS DP port and the data rate is detected, independently of the status on fibre optical link.

### Redundant power supply, galvanic isolated (2 kVAC) to other ports

ODW-611 should be supplied with safety extra low voltage (SELV). It is designed to operate permanently over a wide input range and provided with two independent inputs for enhanced redundancy if either supply fails.

### 9-position D-sub PROFIBUS DP connector

The pin assignment for the connector is in compliance with PROFIBUS standard EN 50 170.

## Single- or multimode LC fibre connectors

ODW-611 uses Small Form Factor Pluggable (SFP) transceivers that are in compliance with Multi-Sourcing Agreement (MSA). A wide range of different fibre transceivers and connectors can be used.

## Status port

This port enables supervision of fibre optical link status by a relay with both normally open and closed contacts.

The status will be set if:

- Local or remote fibre link errors exist.
- The unit is out of service, e.g. no power supply.

## Designed for harsh environments, such as industrial, road and railway applications

ODW-611 complies with standards for industrial environments and railway signalling and telecommunications apparatus. Additionally the wide temperature range ODW-611 permits it to be installed in out-door cabinets without any additional measures, such as heating, etc.

## System delay in an optical network

PROFIBUS DP data transferred from one ODW-611 unit via an optical network to a second unit will be delayed, due to the length of optical fibre and the signal processing within the unit. The signal processing delay is dependent on the data rate, and the fibre delay is dependent on the total length of the optical fibre.

	Delay @ Up to 1.5 Mbit/s	Delay @ 3 /12 Mbit/s
Optical fibre length delay (typical)	5 µs/km	5 µs/km
Signal processing, electrical to fibre (max)	1 $t_{\text{Bit}}$ + 1.0 µs	5 $t_{\text{Bit}}$ + 1.0 µs
Signal processing, fibre to electrical (max)	0.3 µs	0.3 µs
Overall system delay, one-way. From received PROFIBUS DP data at one unit until transmitted data at the other unit	5 µs/km + 1.0 µs + 1 $t_{\text{Bit}}$	5 µs/km + 1.0 µs + 5 $t_{\text{Bit}}$

**Note**  $t_{\text{Bit}} = 1 / \text{Baud rate}$  (Baud rate in Bit/s)

## Example

Overall system delay, one-way	Delay @ 0.5 Mbit/s	Delay @ 1.5 Mbit/s	Delay @ 12 Mbit/s
200 m fibre length	4.0 µs	2.7 µs	2.4 µs
2000 m fibre length	13.0 µs	11.7 µs	11.4 µs

During configuration of the PROFIBUS DP master it may be necessary to adjust the bus parameter Slot time, the monitoring time ( $t_{\text{Bit}}$ ) of the sender of the frame for acknowledgement of recipient. The additional time resulting from the optical fibre and ODW-611 is twice the overall one-way delay.

## Interface specifications

<b>Power</b>	
Rated voltage	12 to 48 VDC 24 VAC
Operating voltage	10 to 60 VDC 20–30 VAC
Rated current	300 mA @ 12 VDC 150 mA @ 24 VDC 75 mA @ 48 VDC
Rated frequency	DC
Inrush current I <sup>2</sup> t	0.2 A <sup>2</sup> s
Startup current*	1.0 A peak
Polarity	Reverse polarity protected
Redundant power input	Yes
Isolation to	PROFIBUS DP and Status port
Connection	Detachable screw terminal
Connector size	0.2 – 2.5 mm <sup>2</sup> (AWG 24-12)

\* External supply current capability for proper startup

<b>Status</b>	
Port type	Signal relay, changeover contacts
Rated voltage	Up to 48 VDC
Operating voltage	Up to 60 VDC
Contact rating	500 mA @ 48 VDC
Contact resistance	< 50 mΩ
Isolation to	PROFIBUS DP and Power port
Connection	Detachable screw terminal
Connector size	0.2 – 2.5 mm <sup>2</sup> (AWG 24 – 12)

<b>FX (Fibre)</b>	<b>SM-LC80</b>	<b>SM-LC40</b>	<b>SM-LC15</b>	<b>MM-LC2</b>
Fibre connector	LC duplex	LC duplex	LC duplex	LC duplex
Fibre type	Singlemode 9/125 µm	Singlemode 9/125 µm	Singlemode 9/125 µm	Multimode 62.5/125 and 50/125 µm
Wavelength	1550 nm	1310 nm	1310 nm	1310 nm
Transmitter Output optical power min/max	-5/0 dBm **	-5/0 dBm **	-15/-8 dBm **	-20/-14 dBm *
Receiver Input sensitivity	-34 dBm (max)	-34 dBm (max)	-31 dBm (max)	-31 dBm (max)
Receiver Input optical power Maximum	-5 dBm (min) ***	-3 dBm (min) ***	-8 dBm (min)	-8 dBm (min)
Optical power budget, worst case	29 dB	29 dB	16 dB	1 dB
Bit error rate (BER)	<1 x 10 <sup>-10</sup>	<1 x 10 <sup>-10</sup>	<1 x 10 <sup>-10</sup>	<2.5 x 10 <sup>-10</sup>
Transceiver type	Small Form Factor Pluggable (SFP) Multi-Sourcing Agreement (MSA) compliant			
Laser class	Class 1, IEC 825-1 Accessible Emission Limit (AEL)			

\* Output power is power coupled into a 62.5/125 µm multimode fibre.

\*\* Output power is power coupled into a 9/125 µm singlemode fibre.

\*\*\* The optical power should be reduced by at least 5 dB (SM-LC80)  
or 3dB (SM-LC80) between the optical output and input.

## Optical Power Budget

The maximum supported link lengths as specified in table above should only be seen as indicative. The allowed link length is calculated from the Optical Power Budget (OPB), the available optical power for a fibre-optic link, and the attenuation of the fibre, comprising losses due to in-line connectors, splices, optical switches and a margin for link aging (typical 1.5 dB for 1300 nm).

The worst-case Optical Power Budget (OPB) in dB for a fibre-optic link is determined by the difference between the minimum transmitter output optical power and the lowest receiver sensitivity.



<b>PROFIBUS DP (RS-485)</b>	
Electrical specification	EIA RS-485 / EN 50 170
Data rate	9 600 bit/s, 19.2, 93.75, 187.5, 500 kBit/s, 1.5, 3, 6 and 12 Mbit/s
Data format	8 data bits, even parity, 1 stop bit, 11 bits total
Protocol	PROFIBUS DP / EN 50170
Data Rate detection	Yes, compliant with EN 50 170
Retiming	Yes
Turn around time	In accordance with EN 50 170
Transmission range	≤1200 m, depending on data rate and cable type (EIA RS-485)
Settings	None, external termination and failsafe biasing
Protection	Installation Fault Tolerant (up to ±60 V)
Isolation to	Power and Status port
Connection	9-pin D-sub female
Shielded cable	Not required
Conductive housing	Isolated to all other circuits and housings

# Connections

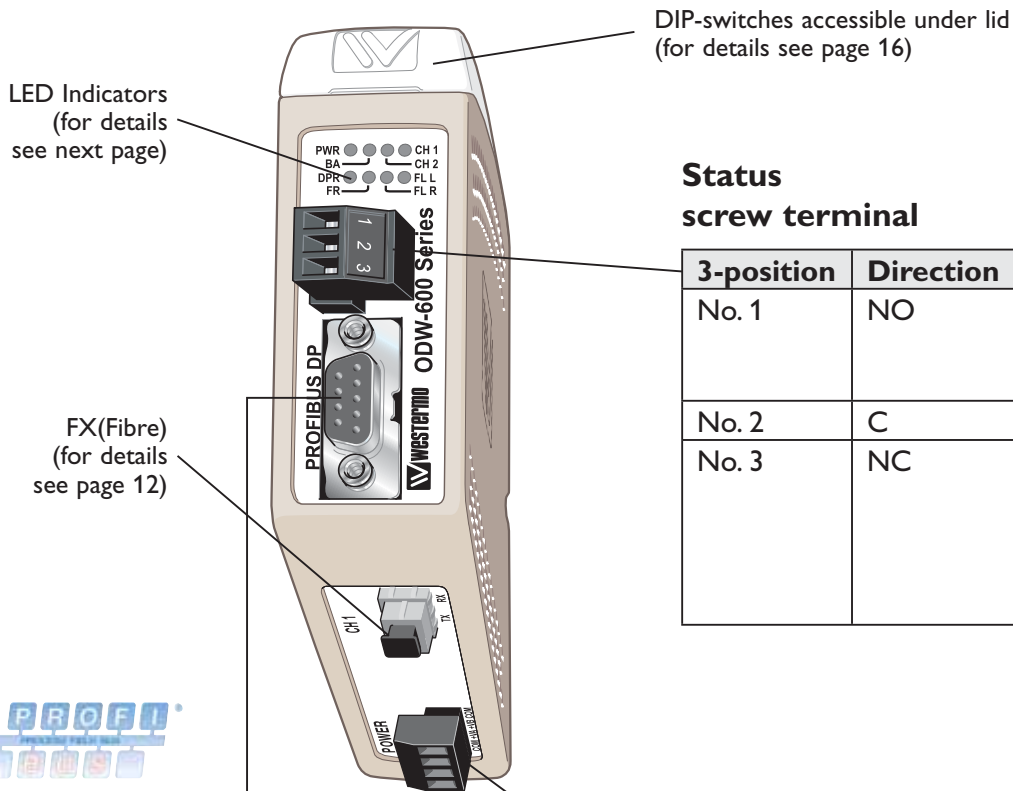

## Status screw terminal

3-position	Direction	Description
No. 1	NO	Contact with C when link is in operation
No. 2	C	Common
No. 3	NC	Open (no contact with C) when fibre link is in operation



## PROFIBUS DP (RS-485) D-sub

9-position	Direction	Description
No. 1	-	-
No. 2	-	-
No. 3	In/Out	RxD/TxD-P
No. 4	Out	CNTR-P
No. 5	-	DGND
No. 6	Out	VP
No. 7	-	-
No. 8	In/Out	RxD/TxD-N
No. 9	-	-

## Power screw terminal

4-position marking	Description
No. 1	-Voltage
No. 2	+Voltage A
No. 3	+Voltage B
No. 4	-Voltage

## LED Indicators

LED	Status	Description
PWR Power	ON	In service (power).
	Flashing	Fault condition.
	OFF	Out of service.
BA Bus active	ON	PROFIBUS DP in operation. Received data frame with detected data rate on the electrical PROFIBUS DP or optical fibre port.
	OFF	Data frame with detected data rate has not been received, or received frames have been interrupted during a time, or a number of consecutive faulty frames*.
CH 2 Channel	ON	Not used
	OFF	Not used
CH 1 Channel	ON	Fibre link at port CH 1 in operation. Data can be transmitted.
	OFF	Fibre link at port CH 1 out of operation.
DPR Receive PROFIBUS DP	Flash	Receive data on the electrical PROFIBUS DP port. Data will be transmitted to the fibre link, if it is a correct PROFIBUS DP frame.
	OFF	–
FR Receive fibre link	Flash	Receive data on the Fibre Link. This frame is transmitted to the PROFIBUS DP channel.
	OFF	–
FL R Failure link remote	ON	Remote Fibre Link failure. A fibre link is out of operation at any other unit of the optical network.
	OFF	All fibre links are in operation at all other units in the fibre optical network.
FL L Failure link local	ON	Local fibre link failure. This unit has identified a fibre link failure.
	OFF	Fibre link of this unit is in operation

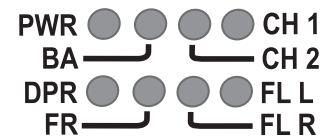

\* Time and number of frames are set by DIP-switch S:2.

# DIP-switch settings



## Before setting DIP-switches:

Prevent damage to internal electronics from electrostatic discharges (ESD) by discharging your body to a grounding point (e.g. use of wrist strap).

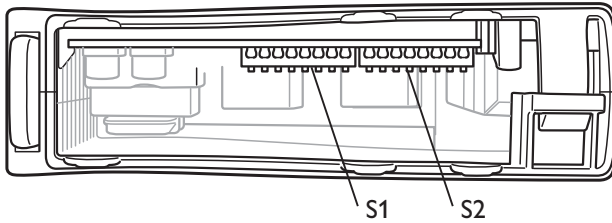

## Faulty frame before data rate is seen as unidentified

S1 DIP-switch	S2 DIP-switch	Description
		1 faulty frame before data rate is seen as unidentified. S1: No extended retry limit.
		2 faulty frame before data rate is seen as unidentified. S1: No extended retry limit.
		3 faulty frame before data rate is seen as unidentified. S1: No extended retry limit.
		4 faulty frame before data rate is seen as unidentified. S1: No extended retry limit.
		5 faulty frame before data rate is seen as unidentified. S1: No extended retry limit.
		6 faulty frame before data rate is seen as unidentified. S1: No extended retry limit.
		7 faulty frame before data rate is seen as unidentified. S1: No extended retry limit.
		8 faulty frame before data rate is seen as unidentified. S1: No extended retry limit.
		31 faulty frame before data rate is seen as unidentified. S1: Extended retry limit.
		63 faulty frame before data rate is seen as unidentified. S1: Extended retry limit.
		127 faulty frame before data rate is seen as unidentified. S1: Extended retry limit.
		255 faulty frame before data rate is seen as unidentified. S1: Extended retry limit.

## S2 DIP-switch



65535  $t_{bit}$  interruption in receiving frames, until inactive BA\*



10 seconds interruption in receiving frames, until inactive BA\*



5 seconds interruption in receiving frames, until inactive BA\*



20 seconds interruption in receiving frames, until inactive BA\*

\* Delay since last correct received frame until PROFIBUS DP is out of operation. (BA LED inactive)

$t_{bit} = 1 / \text{Baud rate}$ . (Baud rate in bit/s)

## Factory settings





## Mounting

This unit should be mounted on 35 mm DIN-rail, which is horizontally mounted inside an apparatus cabinet, or similar. Snap on mounting, see figure.

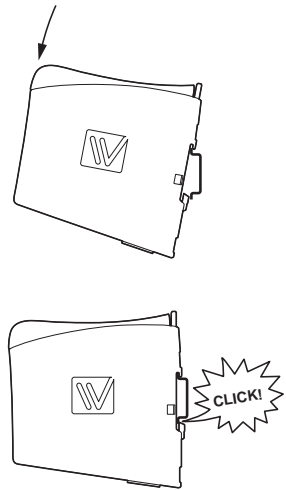

## Cooling

This unit uses convection cooling. To avoid obstructing the air-flow around the unit, use the following spacing rules. Minimum spacing 25 mm (1.0 inch) above /below and 10 mm (0.4 inches) left /right the unit. Spacing is recommended for the use of unit in full operating temperature range and service life.

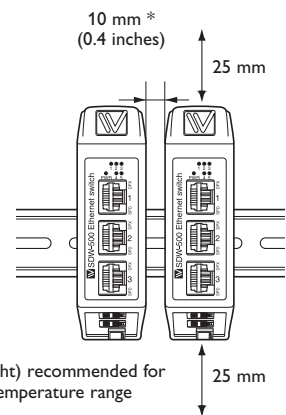

## Removal

Press down the black support at the top of the unit. See figure.

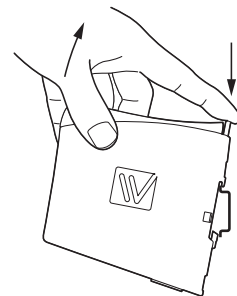

## Start up guide

Follow the steps below to get the unit up and running in a simple application.

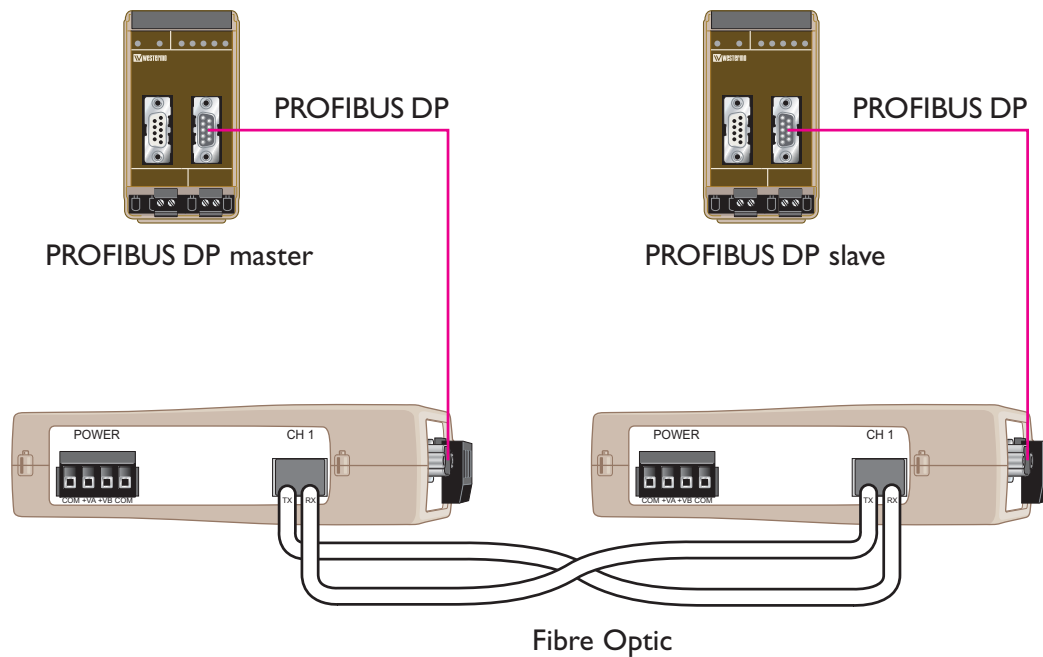

- ⌘ Use the factory DIP-switch settings.
- ⌘ Connect The fibre link between the both units.
- ⌘ Connect the power supply to both ODW-611.
  - The Fibre link should be in operation, indicated by active CH1 LED.
- ⌘ Connect the PROFIBUS DP connectors between both ODW-611 and PROFIBUS units configured to be units in the PROFIBUS DP network.
  - The PROFIBUS DP will be in operation and the data rate should have been identified, indicated by BA LED.
- ⌘ The point to point application is up and running.

## Hints

- ⌘ If the distance is long it may be necessary to adjust the bus parameter Slot time, the monitoring time ( $t_{Bit}$ ) of the sender of frame for acknowledgement of recipient, at configuration of the PROFIBUS DP master.
- ⌘ If the time between transferred PROFIBUS DP frames is long, it may be necessary to allow a longer time of interruption in receiving frames, using DIP-switches.
- ⌘ If disturbances in the PROFIBUS DP network, result in missed frames, it may be necessary to allow a number of consecutive faulty frames before the bus is out of operation, using DIP-switches.



Westermo Teleindustri AB • SE-640 40 Stora Sundby, Sweden  
Phone +46 16 42 80 00 Fax +46 16 42 80 01  
E-mail: [info@westermo.se](mailto:info@westermo.se)  
**Westermo Web site: [www.westermo.com](http://www.westermo.com)**

### Subsidiaries

---

Westermo Data Communications AB  
SE-724 81 Västerås  
Phone: +46 (0)16 42 80 00 • Fax: +46 (0)21 35 18 50  
[info.sverige@westermo.se](mailto:info.sverige@westermo.se)

Westermo OnTime AS  
Gladsvei 20 0489 Oslo, Norway  
Phone +47 22 09 03 03 • Fax +47 22 09 03 10  
E-mail: [contact@ontimenet.com](mailto:contact@ontimenet.com)

Westermo Data Communications Ltd  
Talisman Business Centre • Duncan Road  
Park Gate, Southampton • SO31 7GA  
Phone: +44(0)1489 580-585 • Fax: +44(0)1489 580586  
E-Mail: [sales@westermo.co.uk](mailto:sales@westermo.co.uk)

Westermo Data Communications GmbH  
Goethestraße 67, 68753 Waghäusel  
Tel.: +49(0)7254-95400-0 • Fax: +49(0)7254-95400-9  
E-Mail: [info@westermo.de](mailto:info@westermo.de)

Westermo Data Communications S.A.R.L.  
9 Chemin de Chilly 91160 CHAMPLAN  
Tél : +33 1 69 10 21 00 • Fax : +33 1 69 10 21 01  
E-mail : [infos@westermo.fr](mailto:infos@westermo.fr)

Westermo Data Communications Pte Ltd  
2 Soon Wing Road #08-05  
Soon Wing Industrial Building  
Singapore 347893  
Phone +65 6743 9801 • Fax +65 6745 0670  
E-mail: [earnestphua@westermo.com.sg](mailto:earnestphua@westermo.com.sg)

*Westermo Teleindustri AB have distributors in several countries, contact us for further information.*