



Lynx-series

Lynx 100 / 1100, 300 / 1300
and 400 / 1400

One switch many solutions

The Lynx is a family of switches consisting of models with four different function levels and two different type approvals, giving you the ability to select the perfect switch for your application providing optimum functionality at the best value.

The Lynx family can be configured with either 100 Mbit or Gbit transceivers, the transceivers are then available for ranges up to 120 km.

Redundancy and real-time Ethernet

Our unique FRNT (Fast Recovery of Network Topology) technology is the fastest protocol on the market to re-configure a large network in the event of any failure of a link or hardware. That is why the Lynx-series is used in safety critical applications such as tunnels, traffic signal control and railway systems.

Real-time properties are implemented in order to achieve determinism for real time critical applications. The switches support QoS (Quality of Service) with four priority queues and strict priority scheduling as well as HoL (Head of Line Blocking Prevention). All to ensure that the data network is deterministic.

Harsh industrial environment

The units are well prepared for use in harsh industrial environments. The DIN mounted metal case of the unit makes it robust and allows for the surrounding air temperature to be between -40 to 70°C . To allow for uninterrupted communication the units are supplied with redundant power inputs that can be powered from two separate supplies and handle an operating voltage range of $16 - 60\text{VDC}$.

Approvals

The construction of the units has gone through extensive testing and approvals both by Westermo and approved test houses. The Lynx-series has approvals for industrial as well as for substation use.



Industrial^{IT}
enabled

Application

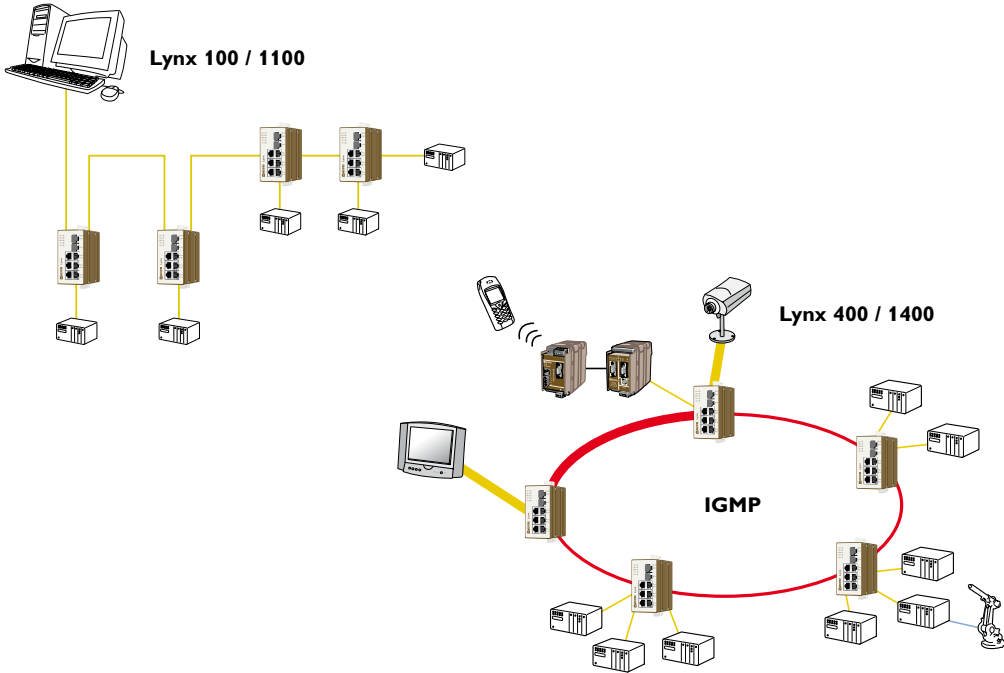

Interfaces

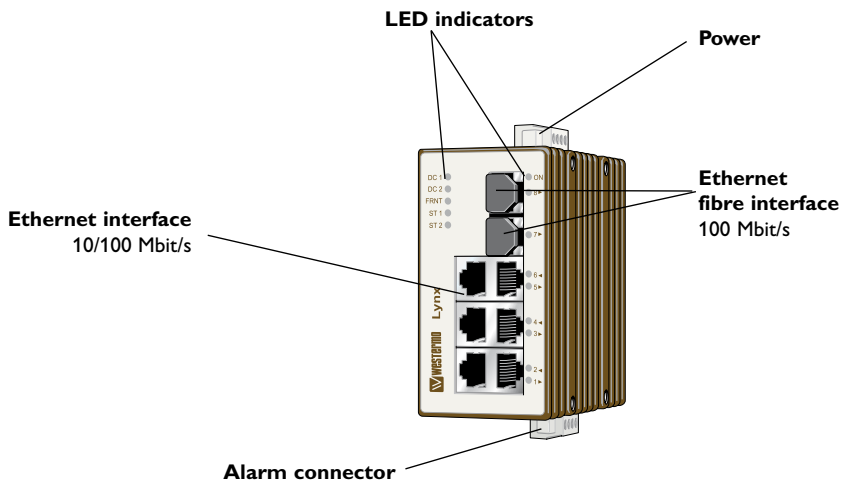

Technical data

Power	
Operating voltage	19 to 60 VDC
Rated current	146 mA @ 24 VDC 80 mA @ 48 VDC
Rated frequency	DC
Inrush current, I ² t	49·10 ⁻⁴ A ² s @ 48 VDC
Startup current*	250 mA @ 24 VDC
Polarity	Reverse polarity protected
Redundant power input	Yes
Isolation to	All other
Connection	Detachable screw terminal
Connector size	0.2 – 2.5 mm ² (AWG 24 – 12)
Shielded cable	Not required

* If external power supply is used it must meet specified inrush current.

Ethernet TX	
Electrical specification	IEEE std 802.3. 2000 Edition
Data rate	10 Mbit/s, 100 Mbit/s, manual or auto
Duplex	Full or half, manual or auto
Circuit type	SELV
Transmission range	150 m, according to long cable specification
Isolation to	Power
Connection	TX connectors: RJ-45 shielded, auto MDI/MDI-X
Shielded cable	Not required, except when installed in Railway applications as signalling and telecommunications apparatus and located close to rails
Conductive housing	Isolated to all other circuits
Number of ports	6

Ethernet SFP pluggable connections (FX or TX)	
Electrical specification	IEEE std 802.3. 2000 Edition
Data rate	100 Mbit/s, 1000 Mbit/s manual or auto
Duplex	Full or half, manual or auto
Circuit type	SELV
Transmission range	Depending on transceiver
Isolation to	Power
Connection	TX connectors: RJ-45 shielded, auto MDI/MDI-XFX connectors: LC
Shielded cable	Not required
Conductive housing	Isolated to all other circuits
Number of ports	1 or 2

Status relay	
Contact resistance	25Ω
Isolation to	1500 VDC
Connection	Detachable screw terminal
Connector size	0.2 – 2.5 mm ² (AWG 24 – 12)

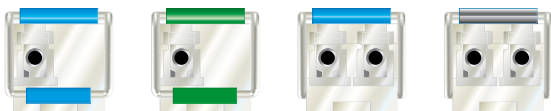

FX 1Gbit (Fibre)	Bi-di LC10	Bi-di LC20	SM-LC80	SM-LC50	SM-LC10	MM-LC2
Connector	LC	LC	LC	LC	LC	LC
Distance km ***	10	20	80	50	10	2
Fibre type μm	Singlemode 9/125	Singlemode 9/125	Singlemode 9/125	Singlemode 9/125	Singlemode 9/125	Multimode 62.5/125 and 50/125
Wavelength nm	Connector 1		1550	1550	1310	1310
	Tx 1310 Rx 1550					
	Connector 2					
	Tx 1550 Rx 1310					
Transmitter Output optical power min/max dBm	-9 **	-8 **	-2 **	-4 **	-9.5 **	-9 *
Receiver Input sensitivity, max dBm	-21	-23	-24	-24	-20	-19
Optical power budget dB	12	15	22	20	10.5	10
Zero cable length	Yes	Yes	No	No	Yes	Yes
Transceiver type	LC Small Form Factor Pluggable (SFP)					
Laser class	Class 1, IEC 825-1 Accessible Emission Limit (AEL)					

* Output power is power coupled into a 62.5/125 μm multimode fibre

** Output power is power coupled into a 9/125 μm singlemode fibre

*** Other distances are also available, please contact Westermo

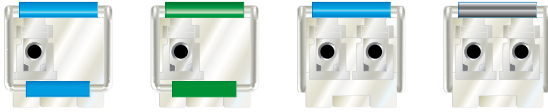

FX100 Mbit (Fibre)	Bi-di LC2	Bi-di LC20	SM-LC80	SM-LC40	SM-LC20	MM-LC2
Connector	LC	LC	LC	LC	LC	LC
Distance km ***	2	20	80	40	20	2
Fibre type μm	Multimode 62.5/125 and 50/125	Singlemode 9/125	Singlemode 9/125	Singlemode 9/125	Singlemode 9/125	Multimode 62.5/125 and 50/125
Wavelength nm	Connector 1		1550	1310	1310	1310
	Tx 1310 Rx 1550					
	Connector 2					
	Tx 1550 Rx 1310					
Transmitter Output optical power min/max dBm	-10 *	-14 **	-5 **	-5 **	-15 **	-19 *
Receiver Input sensitivity, max dBm	-28	-32	-34	-34	-34	-31
Optical power budget dB	18	18	29	29	19	12
Zero cable length	Yes	Yes	Yes	Yes	Yes	Yes
Transceiver type	LC Small Form Factor Pluggable (SFP)					
Laser class	Class 1, IEC 825-1 Accessible Emission Limit (AEL)					

* Output power is power coupled into a 62.5/125 μm multimode fibre

** Output power is power coupled into a 9/125 μm singlemode fibre

*** Other distances are also available, please contact Westermo

Type tests and environmental conditions

Environmental phenomena	Basic standard	Description	Test levels
EMC			
ESD	EN 61000-4-2	Enclosure contact	± 6 kV
		Enclosure air	± 8 kV
RF field AM modulated	IEC 61000-4-3	Enclosure	20 V/m 80% AM (1 kHz), 80 – 2 000 MHz
RF field 900 MHz	ENV 50204	Enclosure	20 V/m pulse modulated 200 Hz, 900 ± 5 MHz
Fast transient	EN 61000-4-4	Signal ports	± 2 kV
		Power ports	± 2 kV
Surge	EN 61000-4-5	Signal ports	± 2 kV line to earth, ± 2 kV potential difference
		Power ports	± 2 kV line to earth, ± 2 kV line to line
RF conducted	EN 61000-4-6	Signal ports	10 V 80% AM (1 kHz), 0.15 – 80 MHz
		Power ports	10 V 80% AM (1 kHz), 0.15 – 80 MHz
Power frequency magnetic field	EN 61000-4-8	Enclosure	1000 A/m, 50 Hz
Pulse magnetic field	EN 61000-4-9	Enclosure	300 A/m
Voltage dips and interruption	EN 61000-4-29	DC power ports	Voltage interruption - 3 x 30s within 5 minutes: 19 V to 0 V & 62.4 V to 0 V Power supply variation – 3 x 1 minute 30% increase and 25% reduction
Radiated emission	EN 55022	Enclosure	Class B
	FCC part 15		Class B
	IEC 60945		Complying with the limit line
Conducted emission	EN 55022	Signal ports	Class B
	EN 55022	DC power ports	Class B
	IEC 60945		Complying with the limit line
Dielectric strength	EN 60950-1	Signal port to other isolated ports	1.5 kVrms 50 Hz 1 min
		Power port to other isolated ports	1.5 kVrms 50 Hz 1 min
Environmental			
Temperature		Operating	-40 to +70°C
		Storage & Transport	-50 to + 85°C
Humidity		Operating	5 to 95% relative humidity
		Storage & Transport	5 to 95% relative humidity
Altitude		Operating	2 000 m / 70 kPa
Service life		Operating	10 year
Vibration	IEC 60068-2-6	Operating	1 mm, 3 – 13.2 Hz 0.7 g, 13.2 – 100 Hz 1.5 g, 5.5 – 30 Hz 0.42 mm, 30 – 50 Hz 4.2 g, 50 – 500 Hz
	IEC 60068-2-64	Operating	0.23 g, 3 – 2000 Hz
Shock	IEC 60068-2-27	Operating	All directions: 2 g, 11 ms Z-axis: 30 g, 11 ms
Bump	IEC 60068-2-29	Operating	2 g, 11 ms
Packaging			
Enclosure	UL 94	Aluminium	Flammability class V-1
Dimension W x H x D With connectors			52.5 x 100 x 101 mm
			52.5 x 119 x 101 mm
Weight			0.6 kg
Degree of protection	IEC 529	Enclosure	IP 40
Cooling			Convection
Mounting			Horizontal on 35 mm DIN-rail