

**LD-64  
Profibus**

# INSTALLATIONSANVISNING INSTALLATION MANUAL INSTALLATIONS ANLEITUNG

6073-2031

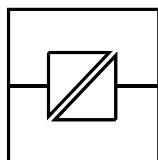

Galvanic  
Isolation

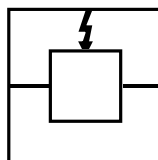

Transient  
Protection

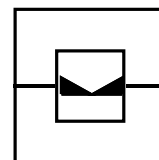

Balanced  
Transmission

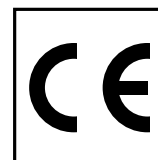

CE  
Approved

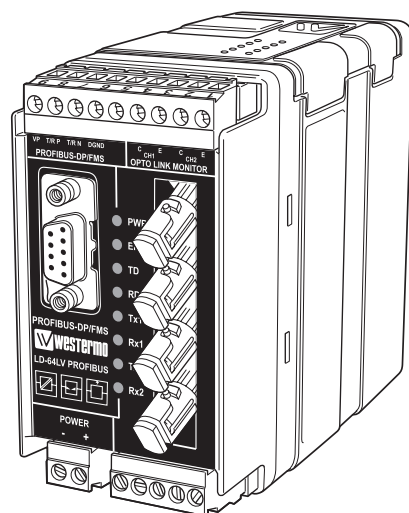

***Fiberoptiskt redundant modem  
– Profibus, RS-485***

***Fibre-optic redundant modem  
– Profibus, RS-485***

***Glasfaser redundante Leitungsteiler  
– Profibus, RS-485***

 **westermo**<sup>®</sup>

[www.westermo.se](http://www.westermo.se)

## Specifications LD-64 Profibus

<b>Transmission</b>	Asynchronous, full/half duplex or simplex
<b>Interface 1</b>	EIA RS-485 / ITU-T V.11 Profibus standard 9-position D-sub alt. 5-position screw block
<b>Interface 2</b>	Fibre optical 4 ST-connections
<b>Data rate</b>	9.6, 19.2, 93.75, 187.5, 500, 1 500 kbit/s
<b>Indicators</b>	PWR, TD, ERR, RD, Tx1, Rx1, Tx2, Rx2
<b>Temperature range</b>	5–50°C ambient temperature
<b>Humidity</b>	0–95% RH without condensation
<b>Dimension</b>	55x100x128 mm (WxHxD)
<b>Weight</b>	0.4 kg
<b>Mounting</b>	On 35mm DIN-rail

### Power supply alternatives

Model description	LD-64HV PROFIBUS	LD-64LV PROFIBUS
Power supply	95–240V AC $\pm$ 5% / 110–240V DC $\pm$ 5%	12–45V AC $\pm$ 5% / 12–55V DC $\pm$ 5%
Frequency	48–62 Hz / –	48–62 Hz / –
Fuse, FI	1 A T / 1 A T Wickmann	1 A T / 1 A T Wickmann
Power consumption	30 mA	3 W
Transient protection Power/Line	Yes/–	Yes/–
Isolation, RMS Power supply	3 750 V	3 750 V

## LEDs for indication on LD-64 Profibus

- PWR: Indicates that the unit has power.
- ERR: Indicates interruption on any fibre channel.
- TD: Indicates received data on Profibus/RS-485 side.
- RD: Indicates transmitting data on Profibus/RS-485 side.
- Rx1: Indicates received data on fibre channel 1.
- Rx2: Indicates received data on fibre channel 2.
- Tx1: Indicates sending data on fibre channel 1 from Profibus/RS-485 side.
- Tx2: Indicates sending data on fibre channel 2 from Profibus/RS-485 side.

## Functional description LD-64 Profibus

LD-64 offers redundant fibre optic communication between equipment with RS-485 interface. The unit is specially developed for Profibus and uses a Profibus standard 9-position D-sub for connection with RS-485. Possibility to connect to a 5-position screw block is also available.

The fibre optic interface uses ST-connectors and both multi mode and single mode fibre versions are available. The maximum transmission distance is calculated from the available power budget of the modems and the attenuation of the cable, splice joints and connectors. Distances up to 25 km can be reached using single mode fibres.

The LD-64 units are used in a ring connection and one unit is configured via switches as the master. The redundant logical system will control the flow of the data during fault conditions. If a break is detected on a fibre or pair of fibres the data will be re-routed. This operation will take approximately 4 ms and all data transmitted during this period will be lost and will need to be resent.

The unit has indications for dataflow and also fault alarm outputs for each fibre optical channel which for example can control an external relay. The alarm outputs will be activated as long as the fault persists.

As with all other Westermo products the LD-64 Profibus provides a high level of galvanic isolation on the power supply side through transformers and also on the alarm side through optocouplers.

LD-64 Profibus can be used at all standard Profibus transmission speeds up to 1.5 Mbit/s and all operating parameters are set-up via DIP switches easily accessible under the lid on the top of each unit.

LD-64 Profibus is available in low (LV) and high voltage (HV) versions. LD-64LV supports power supplies 12–45V AC  $\pm$  5% and 12–55V DC  $\pm$  5%. LD-64HV supports power supplies 95–240V AC  $\pm$  5% and 110–240V DC  $\pm$  5%.

## Description of redundancy

LD-64 Profibus is connected through two parallel fibre optical rings, ring 1 and ring 2. The ring topology introduces the possibility for the units to handle a fault on a fibre or a fibre pair and still maintain communication. The units will automatically change the communication path when a fault is detected. This change can take up to 4ms and all data sent during this time needs to be resent since the modems do not have any possibility to databuffer.

One modem in the ring needs to be configured as master through switches inside the unit. The master controls the data and prevents data to be resent through the ring. The master is also used for monitoring of the fibre rings since all faults detected in the rings will be sent to the master. This gives possibility to monitor the complete system through the master unit. The other modems in the ring needs to be configured as slaves and will be transparent during normal communication.

LD-64 Profibus is equipped with alarm signals which is used for indication of fibre interruptions. Each unit is equipped with two alarm ports, one for each fibre channel. These ports are marked as CE1 and CE2 on the unit. A fault will close the circuit between indications “C” and “E” on respective port. The alarm outputs can for example be used for connection of an external relay. See *connection and examples on page 19–20*.

There is also a led indication for fibre interruption. This makes it easy to locate an interruption.

An interruption will be detected by the closest unit which will indicate a receiver alarm and also send the error further to the master unit which will indicate a corresponding fault for the ring.

***For correct function the fibre optic rings needs to be connected correct between each modem***

Ring 1: Tx1 – Rx2 – Tx1 – Rx2 etc.

Ring 2: Tx2 – Rx1 – Tx2 – Rx1 etc.

Below follows a number of different fault situations which shows the different alarm outputs.

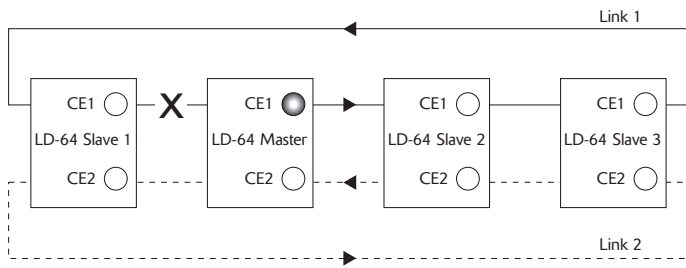

The receiver Rx2 at the master modem detects an interruption on ring 1. Alarm output CE1 indicates at the master unit.

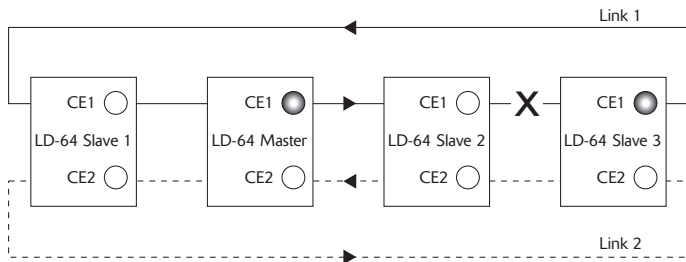

The receiver Rx2 on slave modem 3 detects an interruption on ring 1. Alarm signal CE1 indicates at slave modem 3 and also at the master unit.

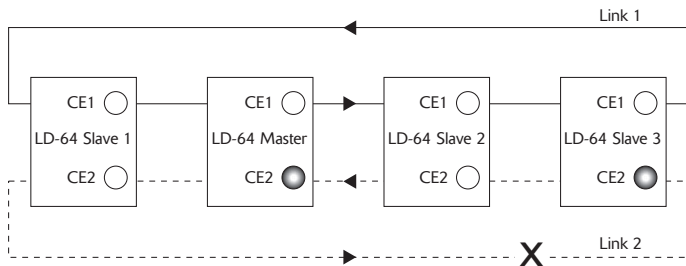

The receiver Rx1 on slave modem 3 detects an interruption on ring 2. Alarm signal CE2 indicates at slave modem 3 and also at the master unit.

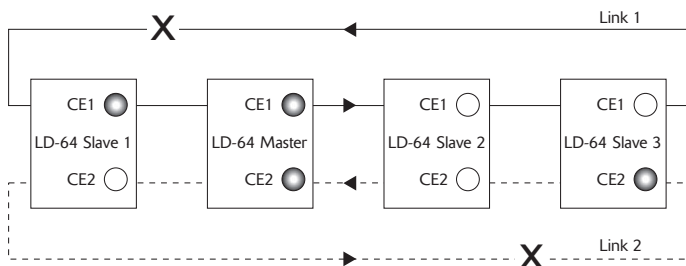

The receiver Rx1 on slave modem 3 and receiver Rx2 on slave modem 1 detects interruptions. Alarm signal CE2 indicates on slave modem 3 and CE1 indicates on slave modem 1. Both CE1 and CE2 indicates at the master unit.

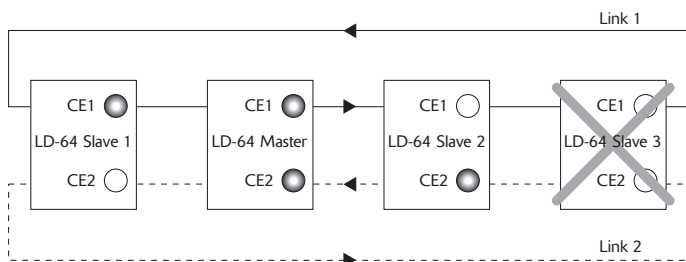

Slave modem 3 stops working due to lack of power or other reason. Receiver Rx2 on slave modem 1 and receiver Rx1 on slave modem 2 detects interruptions. Alarm signal CE1 indicates on slave modem 1 and CE2 indicates on slave modem 2. Both CE1 and CE2 indicates on master modem.

## Power budget

### Min. budget



Unit			
Fibre	820 nm	1300 nm	single mode
50/125	10.7 dB	8.1 dB	
62.5/125	14.5 dB	11.6 dB	
100/140	20.6 dB		
9/125			6.3 dB

### Typ. budget



Unit			
Fibre	820 nm	1300 nm	single mode
50/125	16.6 dB	14.6 dB	
62.5/125	18.6 dB	15.1 dB	
100/140	25.9 dB		
9/125			12.3 dB

"Min. budget" states the minimum guaranteed power budget. Experience shows however that the typical value is in the range of the indicated "Typ. budget".

## Attenuation in fibre cable

The values below can differ depending on quality and manufacturer of the fibre optic cable.

Fibre	Attenuation at 820 nm	Attenuation at 1300 nm	Attenuation at single mode (1300 nm)
50/125 µm	3.0 dB/km	1.0 dB/km	
62.5/125 µm	3.5 dB/km	1.2 dB/km	
100/140 µm	4.0 dB/km		
9/125 µm			0.5 dB/km

## Attenuation in connectors

0.2–0.4 dB

## Attenuation in splice

Fusion 0.1 dB

Mecanical 0.2 dB

# Switch settings LD-64 Profibus



### Selection of master/slave

SI  ON           Slave

SI  ON           Master

Please note that only one master can be used per system

### Selection of retiming

SI  ON           Retiming activated

SI  ON           Retiming inactivated

Retiming implies that the incoming data on fibre side will be retimed to an exact bitlength depending on configured transmission speed. This gives the possibility to connect an increased number of units in serie.

### Selection of data rate / Number of units

	Data rate	Number of units
SI <input checked="" type="checkbox"/> ON <input type="checkbox"/> <input type="checkbox"/> <input type="checkbox"/> <input type="checkbox"/> <input type="checkbox"/> <input type="checkbox"/> <input type="checkbox"/> <input type="checkbox"/> <input type="checkbox"/> <input type="checkbox"/>	9.6 kbit/s	20
SI <input type="checkbox"/> ON <input type="checkbox"/> <input type="checkbox"/> <input type="checkbox"/> <input type="checkbox"/> <input type="checkbox"/> <input type="checkbox"/> <input type="checkbox"/> <input type="checkbox"/> <input type="checkbox"/> <input type="checkbox"/>	19.2 kbit/s	20
SI <input type="checkbox"/> ON <input type="checkbox"/> <input type="checkbox"/> <input type="checkbox"/> <input type="checkbox"/> <input type="checkbox"/> <input type="checkbox"/> <input type="checkbox"/> <input type="checkbox"/> <input type="checkbox"/> <input type="checkbox"/>	93.75 kbit/s	20
SI <input type="checkbox"/> ON <input type="checkbox"/> <input type="checkbox"/> <input type="checkbox"/> <input type="checkbox"/> <input type="checkbox"/> <input type="checkbox"/> <input type="checkbox"/> <input type="checkbox"/> <input type="checkbox"/> <input type="checkbox"/>	187.5 kbit/s	20*)
SI <input type="checkbox"/> ON <input type="checkbox"/> <input type="checkbox"/> <input type="checkbox"/> <input type="checkbox"/> <input type="checkbox"/> <input type="checkbox"/> <input type="checkbox"/> <input type="checkbox"/> <input type="checkbox"/> <input type="checkbox"/>	500 kbit/s	20*)
SI <input type="checkbox"/> ON <input type="checkbox"/> <input type="checkbox"/> <input type="checkbox"/> <input type="checkbox"/> <input type="checkbox"/> <input type="checkbox"/> <input type="checkbox"/> <input type="checkbox"/> <input type="checkbox"/> <input type="checkbox"/>	1 500 kbit/s	20*)

\*) Active retiming

Number of units is depending on the data rate and the total system, retiming (see S1:2) increases the number of possible units but also introduces a delay in the system. "Number of units" means a typical value that can be changed depending on the structure of the total system.



# Connections LD-64 Profibus

## Line connection

### Connections

Designation	9-pos D-sub pin no.	5-pos screw block pin no.	Description
T/R-P	3	8	Line connection – P
T/R-N	8	7	Line connection – N
VP	6	9	+5V supply
DGND	5	6	Signal ground

### Cable types

Designation	Impedance	Capacitance	Resistance	Conductor area
Cable type A	135–165Ω (3–20MHz)	<30pF/m	<110Ω/km	≥0,34 mm <sup>2</sup> (22AWG)
Cable type B	100–130Ω (>100kHz)	<60pF7m	–	≥0,22 mm <sup>2</sup> (24AWG)

### Connection example

Profibus DP/FMS

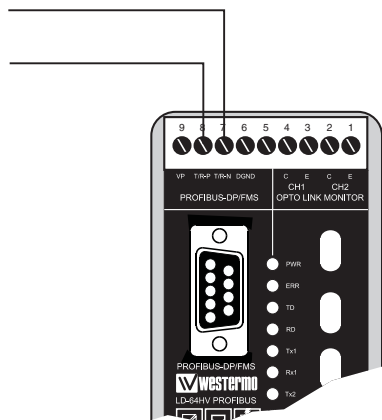

Connection to screw block-terminal

Profibus DP/FMS

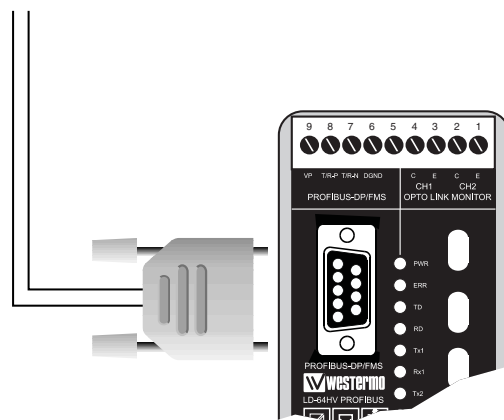

Connection to 9-pos D-sub

## Power connections

### Connection LD-64LV Profibus

#### 2-position screw-terminal

Screw no.	Power supply
1	– Low voltage
2	+ Low voltage

### Connection LD-64HV Profibus

#### 3-position screw-terminal

Connection	Power supply
L	– High voltage
N	+ High voltage
O	Protective earth

## Fibre optic connection

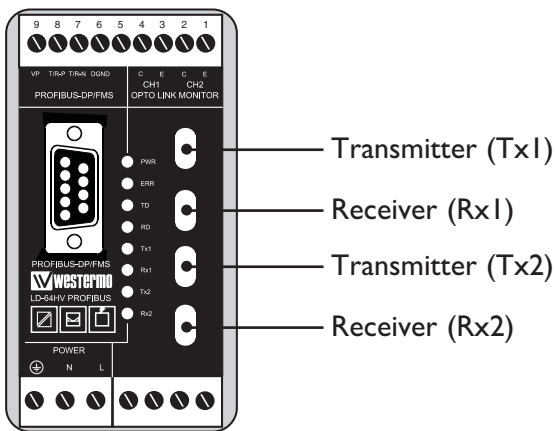
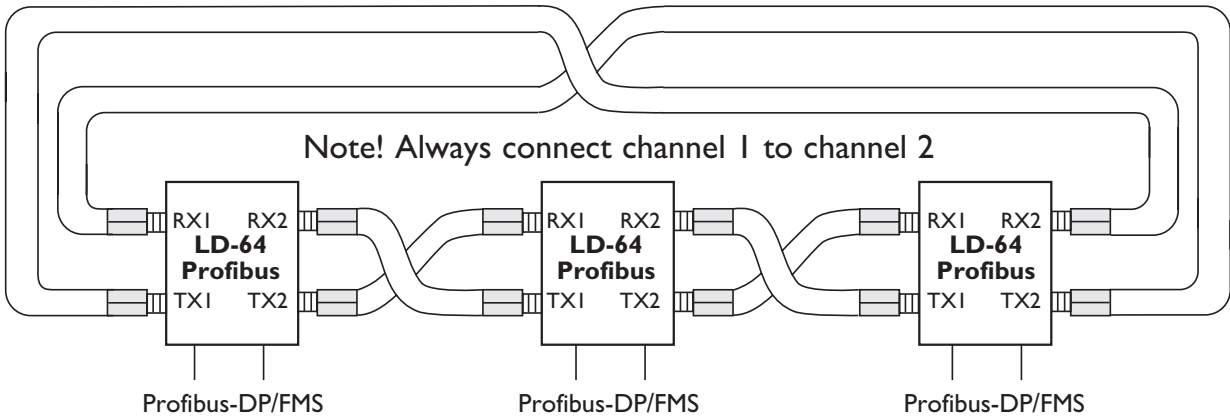

## Alarm connections (Opto Link Monitor)

Upon failure the circuit between the contacts C and E is closed.  
Please note that the maximum allowed voltage/current is 30 V / 80 mA.

The alarm connection can for example be used to control an external relay.

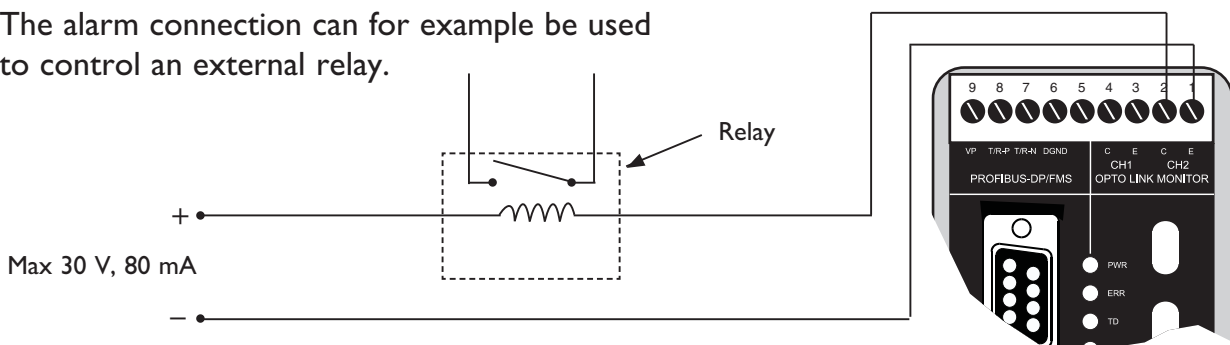

In this example only channel 2 is connected. Under normal operation channel 1 **and** channel 2 should be connected.



## Application example

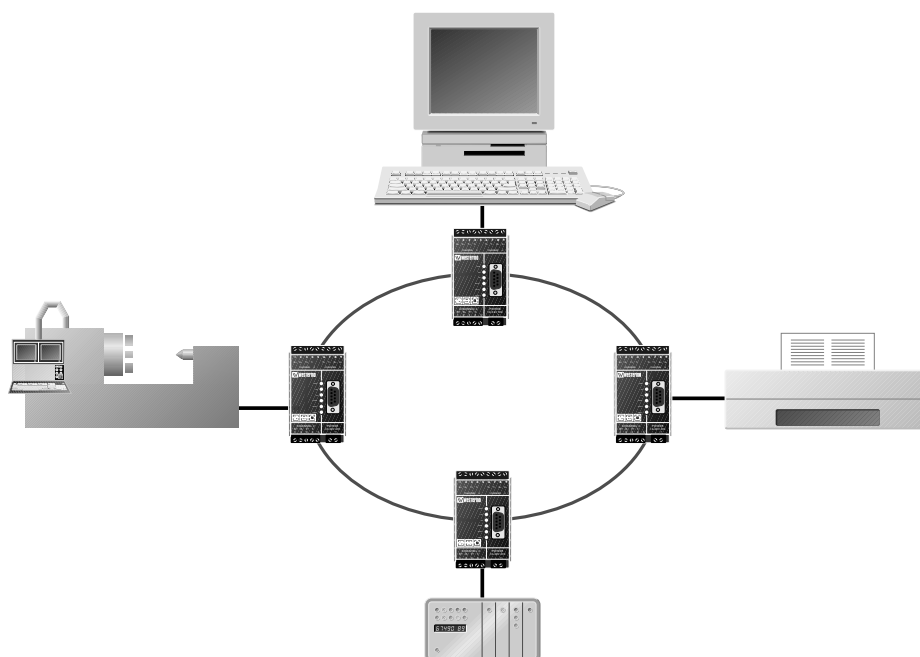

Westermo Teleindustri AB • SE-640 40 Stora Sundby, Sweden  
Phone +46 16 42 80 00 Fax +46 16 42 80 01  
E-mail: [info@westermo.se](mailto:info@westermo.se) • Westermo Web site: [www.westermo.se](http://www.westermo.se)

### Subsidiaries

Westermo Data Communications Ltd  
Unit 14 Talisman Business Centre • Duncan Road  
Park Gate, Southampton • SO31 7GA  
Phone: +44(0)1489 580 585 • Fax: +44(0)1489 580586  
E-Mail: [sales@westermo.co.uk](mailto:sales@westermo.co.uk) • Web: [www.westermo.co.uk](http://www.westermo.co.uk)

Westermo Data Communications GmbH  
Goethestraße 67, 68753 Waghäusel  
Tel.: +49(0)7254-95400-0 • Fax: +49(0)7254-95400-9  
E-Mail: [info@westermo.de](mailto:info@westermo.de) • Web: [www.westermo.de](http://www.westermo.de)

Westermo Data Communications S.A.R.L.  
9 Chemin de Chilly 91160 CHAMPLAN  
Tél : +33 1 69 10 21 00 • Fax : +33 1 69 10 21 01  
E-mail : [infos@westermo.fr](mailto:infos@westermo.fr) • Site WEB: [www.westermo.fr](http://www.westermo.fr)

*Westermo Teleindustri AB have distributors in several countries, contact us for further information.*