

LD-63B AC
LD-63B DC

INSTALLATIONSANVISNING INSTALLATION MANUAL INSTALLATIONS ANLEITUNG

6072-2021

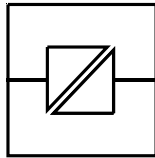

Galvanic
Isolation

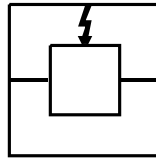

Transient
Protection

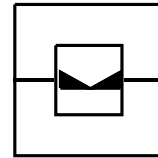

Balanced
Transmission

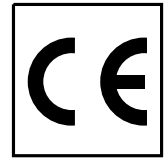

CE
Approved

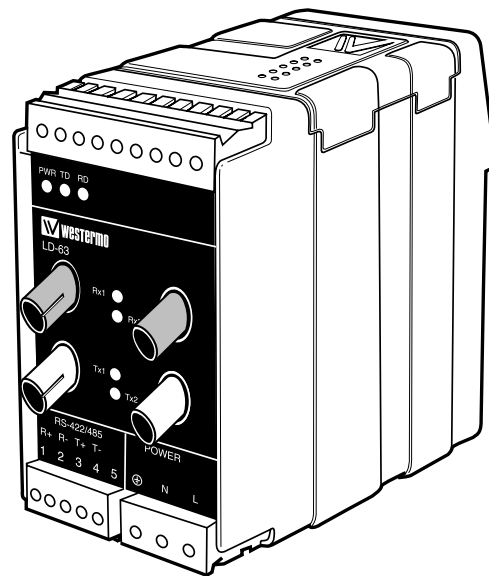

***Linjedelare, optisk fiber
- RS-422/485***

***Line sharing device, fibre optic
- RS-422/485***

***Glasfaser Leitungsteiler
- RS-422/485***



www.westermosales.com



Specifications LD-63B

Transmission	Asynchronous, full/half duplex or simplex
Interface 1	EIA RS-422/RS-485/ CCITT V.11 5-position screw block
Interface 2	4 ST-connectors, see table of power budget
Data rate	500 kbit/s to 4Mbit/s Manchester code*
Indicators	Power, TD, RD, TX1, TX2, RX1, RX2
Temperature range	41–122°F, ambient temperature
Humidity	0–95% RH without condensation
Dimension	2.2x3.9x5 in. (WxHxD)
Weight	0.6 kg
Mounting	On 1.4 in. DIN-rail

Power supply alternatives

Model description	LD-63B AC	LD-63B 115V AC	LD-63B DC	LD-63B 36–55V DC	LD-63B 110V DC
Power supply	230V AC +15/–10%	115V AC +15/–10%	24V DC +50/–50%	48V DC +15/–25%	110V DC/80V AC +10/–10%
Frequency	48–62Hz	48–62Hz	–	–	–/48–62Hz
Fuse, F2	100mA S .2x.8 in. Littelfuse	100mA S .2x.8 in. Littelfuse	1.6A S .2x.8 in. Littelfuse	1.6A S .2x.8 in. Littelfuse	1A T/1A T –/– Wickmann
Power consumption	5VA	5VA	3W	3W	3W/3VA
Overvoltage protection	430V	220V	–	–	430V
Isolation RMS	1 500V	1 500V	500V	500V	3 750V

* For higher data rate, please contact Westermo.

Description LD-63B

The LD-63B is a line splitter for use in multi-drop fiber optic networks. The LD-63B allows conversion between RS-422/485 and fiber optic. LD-63B is specially developed for Manchester coded protocols with transmission rates over 500 kbit/s. The LD-63B consists of two F/O channels, each with its separate transmitter and receiver (TX1, TX2, RX1 and RX2). On the front of the units there are seven LED's indicating the data transmission on the channels. The fiber optic interface is transparent which means that data received on RX1 is retransmitted on TX2 and data received on RX2 on TX1. The number of LD-63B in multidrop is limited. See table of "Maximum number of units" on page 15.

Power budget

The LD-63B is developed for Manchester coded protocols and this means that the power budget will change with the number of preamble bits in the actual protocol. Preamble bits are sent before the actual data and has the function of synchronise units in the network (see figure below).

The LD-63B uses the preamble bits for stabilising before receiving data and this means that the LD-63B will distort the preamble bits used with more than 10%. The diagrams shows the available power budget at different number of available preamble bits and at different transmission speeds.

Observe that the diagrams state the minimum guaranteed power budget. Experience show however that the typical value is about 4 dBm higher with 820 nm, about 3,5 dBm higher with 1300 nm and about 6 dBm higher with singel mode.

Also observe that the calculated values applies between two LD-63B units. In larger networks each fiber optical loop needs to be summated to get the number of used preamble bits.

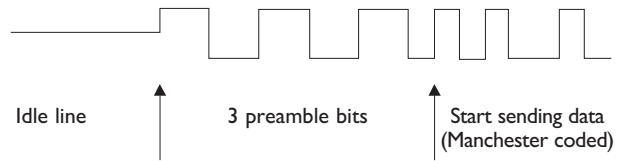

Example:

Calculation of number of used preamble bits.

Connection:

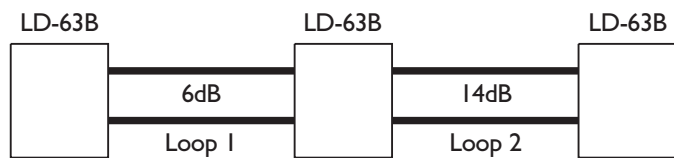

Assume 820 nm units and 1 Mbit/s transmission rate.

This means that fiberloop 1, which need 6 dB, will use maximum 1 preamble bit (from diagram).

Fiberloop 2 needs 14 dB and will use maximum 10 preamble bits (from diagram).

This gives a total maximum of 11 preamble bits.

Minimum guaranteed budget 820nm, 62.5/125µm fiber

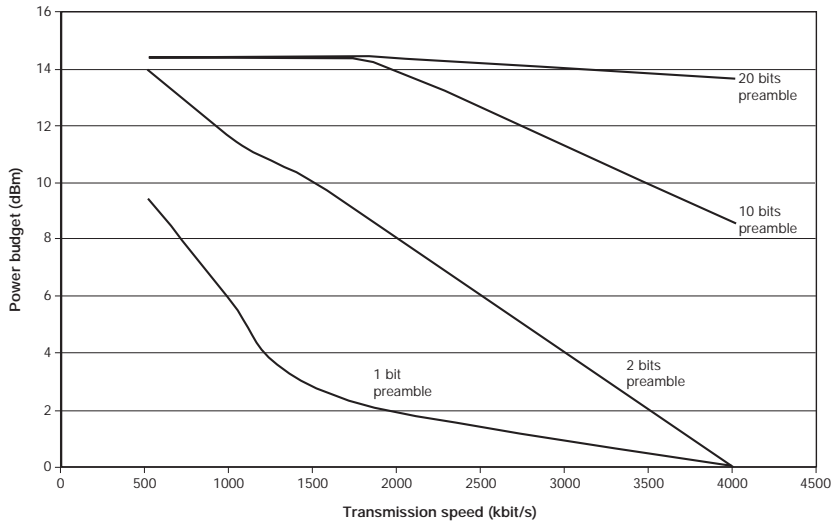

Minimum guaranteed budget 1300nm, 62.5/125µm fiber

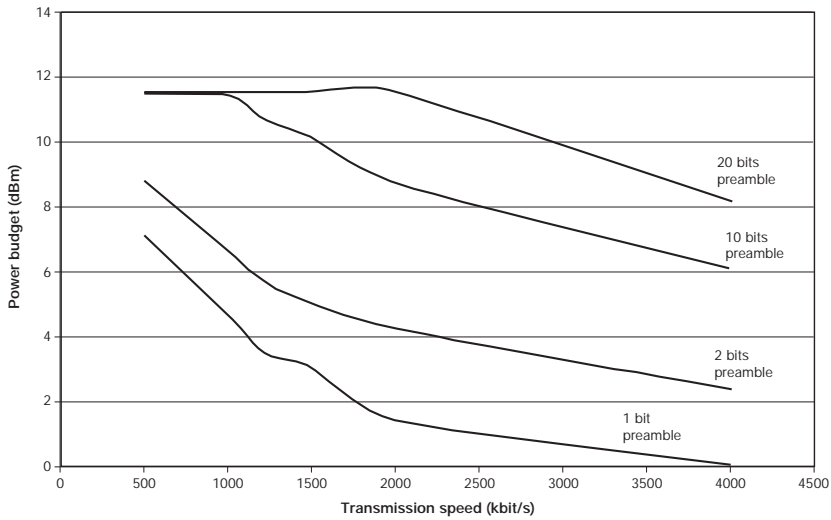

Minimum guaranteed budget single mode, 9/125µm fiber

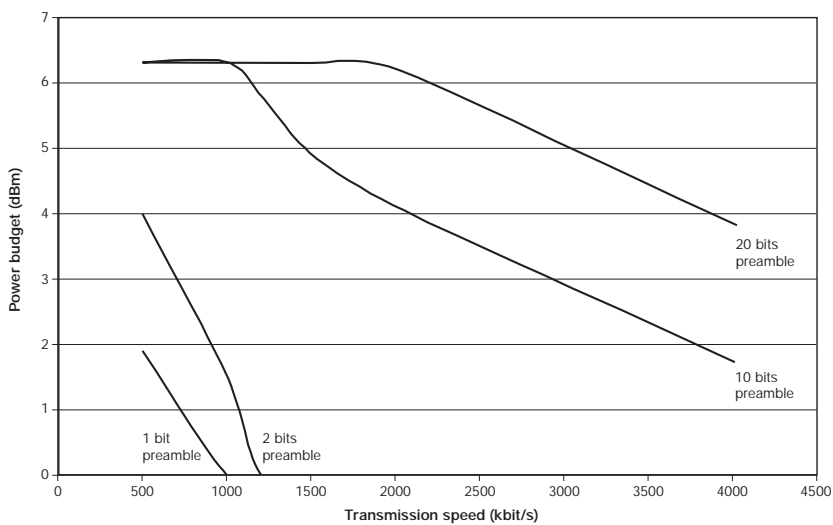

Attenuation in fiber cable

The values below can differ depending on quality and manufacturer of the fiber-optic cable.

Fibre	Attenuation at 820 nm	Attenuation at 1300 nm	Attenuation at single mode (1300 nm)
50/125 µm	3.0 dB/km	1.0 dB/km	
62.5/125 µm	3.5 dB/km	1.2 dB/km	
100/140 µm	4.0 dB/km		
9/125 µm			0.5 dB/km

Attenuation in connectors

0.2–0.4 dB

Attenuation in splice

Fusion 0.1 dB

Mecanical 0.2 dB

LEDs for indication on LD-63B

- PWR: Indicates that the converter has power.
- TD: Indicates that the converter is receiving data on RS-422/485 side.
- RD: Indicates that the converter is sending data on RS-422/485 side.
- Rx1: Indicates received data on fiber channel 1.
- Rx2: Indicates received data on fiber channel 2.
- Tx1: Indicates that the converter is sending data on fiber channel 1 from RS-422/485 side.
- Tx2: Indicates that the converter is sending data on fiber channel 2 from RS-422/485 side.

Switch settings LD-63B

Selection of speed

SI  Over 1 Mbit

SI  Under 1 Mbit

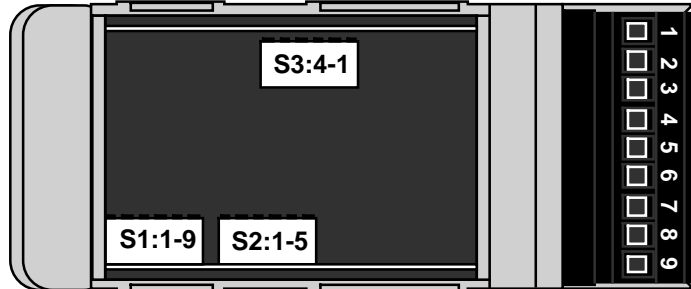

Selection of V or Y function

SI  Y

SI  V

V-mode and Y-mode are described on page 11.

Selection of 2- or 4-wire

SI  4-wire

SI  2-wire

Selection of 2-wire RS-485 or 4-wire RS-422.
S1: 4-9 is not used.

Termination with fail-safe

S2  Termination (2wire)

S2  Termination (4wire)

S2  No termination

The fail-safe function forces the signal state of the receiver to OFF when the connected transmitter is in tri-state (transmitter inactive). The receiver located furthest away shall be terminated.

Transmitted power channel 1

S2  Low

S2  High



Transmitted power channel 2

S3  Low

S3  High

S3: 2-4 not used.

Factory settings

SI  S2  S3 

Connections LD-63B

Line connection

(5-position screw terminal)

Direction	Connection nr.	CCITT V.11 Description
Receiver	1	A' (R+)
Receiver	2	B' (R-)
Transmitter	3	A (T+)
Transmitter	4	B (T-)
	5	Shield

The definitions R+/R-, T+/T- can be various between different manufactures.

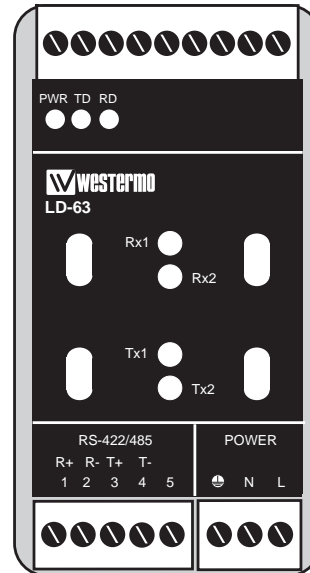

Power connection LD-63B AC

3-position screw-terminal

Screw no.	Power supply
L N	115**/230V AC power
	Earth

* LD-63B 115V

Power connection LD-63B DC

2-position screw-terminal

Connection no.	Power supply
1	- Voltage
2	+ Voltage

Description V/Y mode

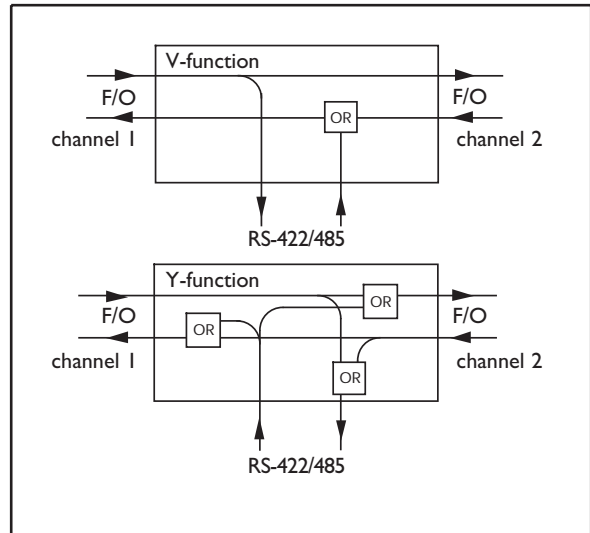

Maximum number of units

Transmission speed	Number of units
500 kbit/s	16
1 Mbit/s	8
2 Mbit/s	4
4 Mbit/s	2

For additional units please contact Westermo

Example: Multidrop

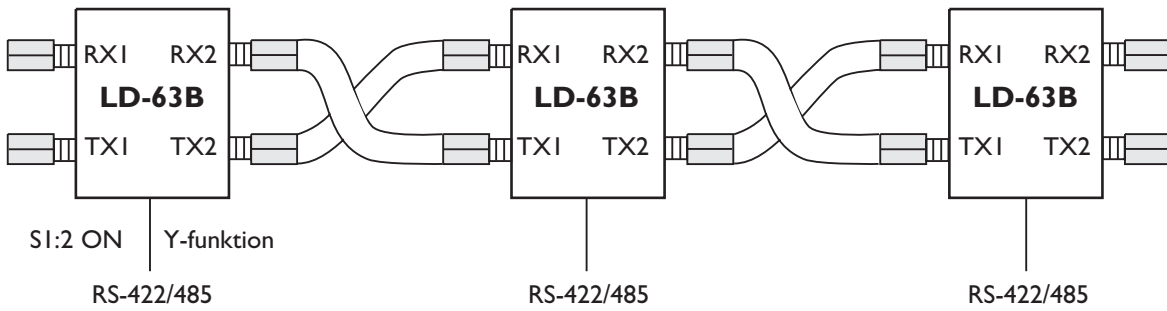

NB When a multidrop connection ends with an LD-63B and the fiber pair is connected on channel 2, the switch S1:2 must be set (Y-function)

Connection of RS-422, RS-485

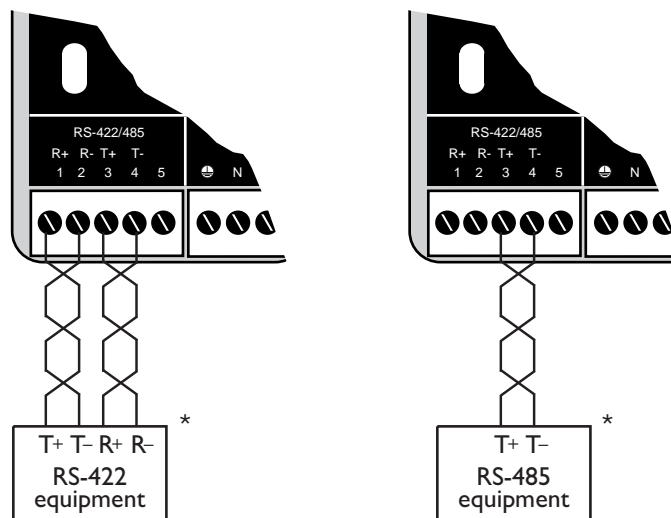

*) The designations A, A', B, B' are sometimes use instead of T+, T-, R+, R-.
Despite the standard, different manufacturers name the signals differently.
The first step in fault finding is to reverse the cables (swap T+ with T- and/or R+ with R-). Please note that this should be done only at one end!

Block diagram

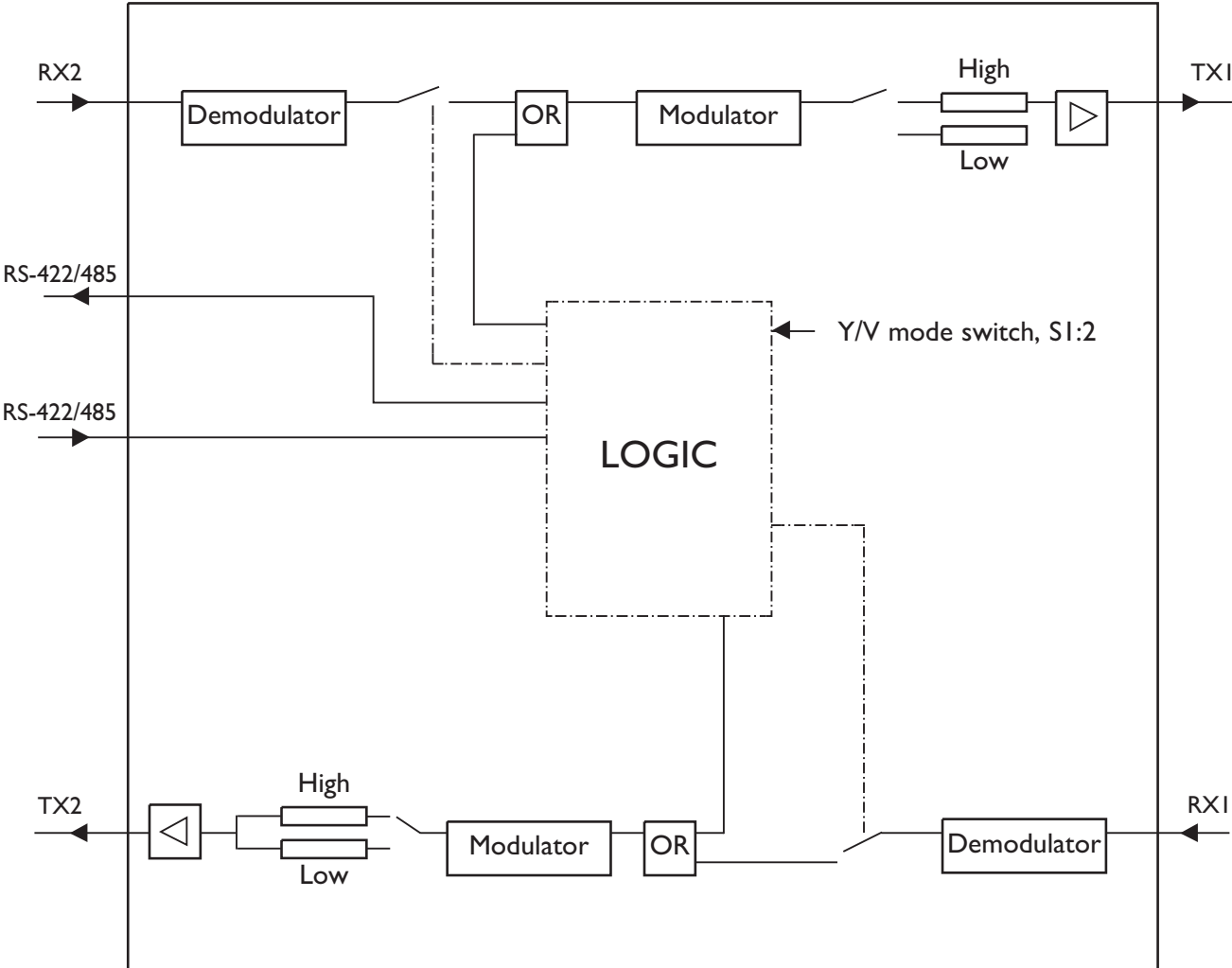

Westermo Teleindustri AB have distributors in several countries, contact us for further information.



Gross Automation (877) 268-3700 · www.westermosales.com · sales@grossautomation.com