

LD-02 AC
LD-02 DC

INSTALLATIONSANVISNING INSTALLATION MANUAL INSTALLATIONS ANLEITUNG

6156-2002

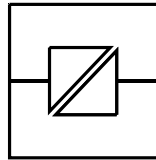

Galvanic
Isolation

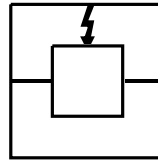

Transient
Protection

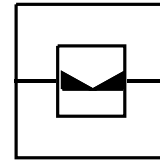

Balanced
Transmission

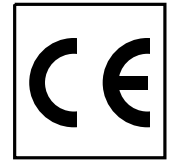

CE
Approved

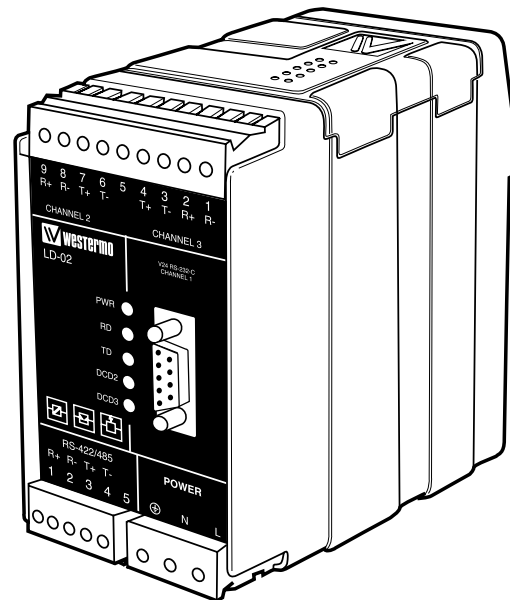

*Linjedelare
Line split unit
Leitungsteiler*

 **westermo**[®]

www.westermosales.com

[®]
WESTERMO

Specifikationer LD-02 AC

Överföring	Asynkron full/halv duplex eller simplex
Gränssnitt 1	EIA RS-232-C/CCITT V.24 på kanal 1
Gränssnitt 2	10mA balanserad strömslinga på kanal 2 och 3
Gränssnitt 3	EIA RS-422/485/CCITT V.11 på kanal 4.
Anslutningar	Kanal 1: 9-polig D-sub hylskontakt Kanal 4: 5-polig skruvplint Kanal 2 och 3: 9-polig skruvplint
Max rekommendrat antal i serie	14 st
Hastighet	Hastigheter upp till 38 400 bit/s
Lysdioder	Power, RD, TD, DCD2, DCD3
Isolation	Fullständig galvanisk isolation med optokopplare (data) resp. transformator (matning)
Isolationsspänning	1500V
Överspänningskydd	Nät: Genombrottsspänning 430V vid 230V AC Gränssnitt 2, 3: Genombrottsspänning sändare 15V, mottagare 5,8V. Avledningsförmåga 0,6 kW under 1 ms Gränssnitt 4: Genombrottsspänning sändare och mottagare 7V. Avledningsförmåga 0,6 kW under 1 ms
Strömförsörjning	230V +15/-10% 48-62Hz
Säkring	100mA snabb 5x20 mm
Effektförbrukning**	Max 25mA vid 230V
Temperaturområde	41-122° F, omgivningstemperatur
Fuktighetsområde	0-95% RH, utan kondensation
Mått	2.2x3.9x5 in.
Vikt	0,4 kg
Montering	På 1.4 in. DIN-skena

Specifikationer LD-02 AC 115V*

Överspänningskydd	Nät: Genombrottsspänning 220V vid 115V AC
Strömförsörjning	115V AC +15/-10% 48-62Hz
Effektförbrukning	Max 50mA vid 115V

Specifikationer LD-02 DC*

Inspänningsområde	12-36V DC
Effektförbrukning	Max 3W
Isolationsspänning	500V
Säkring FI	1,6A snabb .2x.8 mm

* I övrigt gäller LD-02 AC specifikationerna

** För andra matningspänningar kontakta Westermo

Funktionsbeskrivning LD-02

LD-02 är först och främst en linjedelare med följande gränssnitt. Westermos 10 mA balanserade strömslinga WI, RS-232 och RS-485/422. De sistnämnda gränssnitten är parallellkopplade och kan därför inte användas samtidigt.

LD-02 fungerar även utmärkt som omvandlare WI – RS232 eller WI – RS485/422 med fullständig galvanisk isolation mellan gränssnitten.

LD-02 kan även användas för att förlänga RS485/422 multidropslinga t.ex. kan slingan förlängas med 2 500 m vid en dataöverföringshastighet på 9 600 bit/s.

Linjedelaren har fyra kanaler där kanal 1 är RS-232, kanal 2 och 3 är WI. Kanal 4 har RS485/422 gränssnitt. I och med att LD-02 delar upp och förstärker signalen (repeater-funktion) kan ett multidropnät med upp till 14 st LD-02 i serie byggas. Antal LD-02 i serie är begränsat beroende av överföringslängd och datahastighet mellan enheterna.

Inställningar

LD-02 kan genom inställningar anpassas till ett flertal olika driftförhållanden. Samtliga omkopplare i LD-02 görs åtkomliga genom att lådans lock avlägsnas.

VARNING! ÖPPNA EJ ANSLUTEN ENHET

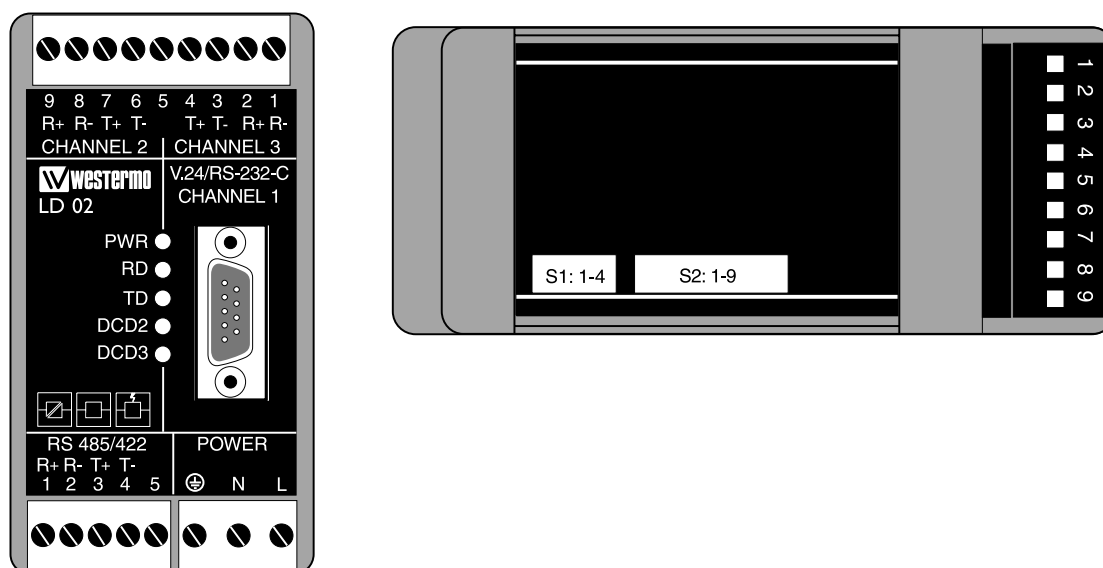

Switchinställningar

Terminering med fail-safe

SI  Terminering 4-tråd (RS-422)

SI  Terminering 2-tråd (RS-485)

SI  Ingen terminering

Val av antal bitar

S2  9

S2  10

S2  11









S2  12

Val av 2/4 tråd

S2  2-tråd

S2  4-tråd

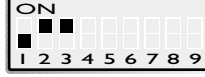
Hastighet



	Val av hastighet	Vänd tid (max)
S2	 300	3,33 ms
S2	 600	1,67 ms
S2	 1200	833 μ s
S2	 2400	417 μ s
S2	 4800	208 μ s
S2	 9600	104 μ s
S2	 19200	52 μ s
S2	 38400	26 μ s

V eller Y funktion

S2  Y

S2  V

Fabriksinställning

SI  S2 

Hjälpmedel för inställning av databitar

7 bitar	•	•	•	•			
8 bitar				•	•	•	•
Ingen paritet	•	•		•	•		
Paritet			•		•	•	•
1 stoppbit	•		•	•		•	
2 stoppbit		•			•		•
antal bitar	9	10	10	10	11	11	12

Anslutningar

RS-232 (kanal 1)

Riktning DCE	Ansl. nr 9-pol D-sub	CCITT V.24 Benämning	Signal beskrivning
O	1	109	DCD/Data Carrier Detect
O	2	104	RD/Received Data
I	3	103	TD/Transmitted Data
I	4	108/2	DTR/Data Terminal Ready
-	5	102	SG/Signal Ground
O	6	107	DSR/Data Set Ready
I	7	105	RTS/Request To Send
O	8	106	CTS/Clear To Send
NC	9		

I=ingång O=utgång. LD-02 är konfigurerad som en DCE. NC=ej inkopplad.

WI, balanserad 10mA (kanal 2 och 3)

Riktning	Ansl. nr		Benämning
	Kanal 2	Kanal 3	
Mottagare	9	2	R+
Mottagare	8	1	R-
Sändare	7	4	T+
Sändare	6	3	T-
	5	5	¹⁾ Skärm

RS-485/422 (kanal 4)

Riktning	Ansl. nr	CCITT V.11 benämning
Mottagare	1	A' (R+)
Mottagare	2	B' (R-)
Sändare	3	A (T+)
Sändare	4	B (T-)
	5	¹⁾ Skärm

RS-485/422 anslutning (kanal 4)

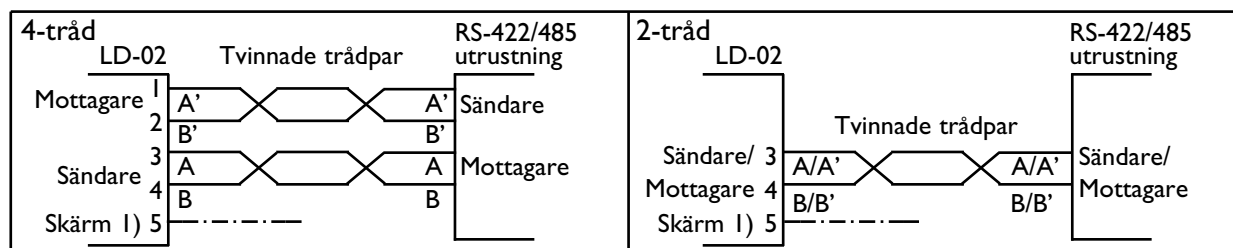

1) Om skärmd kabel används, skall skärmen endast anslutas i ena änden för att undvika jordströmmar

Matninganslutning LD-02 AC 3-polig skruvplint

Ansl. nr	Spänningsanslutning
L	115*/230V
N	AC matning
	Skyddsjord

Matninganslutning LD-02 DC 2-polig skruvplint

Ansl. nr	Spänningsanslutning
1	-Spänning
2	+Spänning

* LD-02 115V

Överföringsavstånd (10mA balanserad strömslinga WI)

Kabel	Överföringshastighet bit/s						
	600	1200	2400	4800	9600	19200	38400
42pF/m 0,3mm ²	18000m	12000m	8000m	5000m	2500m	1000m	500m

Tips

Multidroppkanal I är DCE (Data Communication Equipment), vilket är det vanliga i kommunikationsutrustning, t.ex. modem. Andra utrustningar kan vara av typ DTE (Data Terminal Equipment), t.ex. PC, terminaler och skrivare. Nedan visas förslag till standardkablage.

Om det uppkommer något problem vid inkoppling av LD-02 kan lysdiodsindikeringarna vara till värdefull hjälp vid felsökning.

- PWR: Indikerar att enheten är spänningssatt
- RD: Indikerar att data sänds från kanal 1 eller 4
- TD: Indikerar att data tas emot på kanal 1 eller 4
- DCD2: Indikerar bärväg på kanal 2
- DCD3: Indikerar bärväg på kanal 3

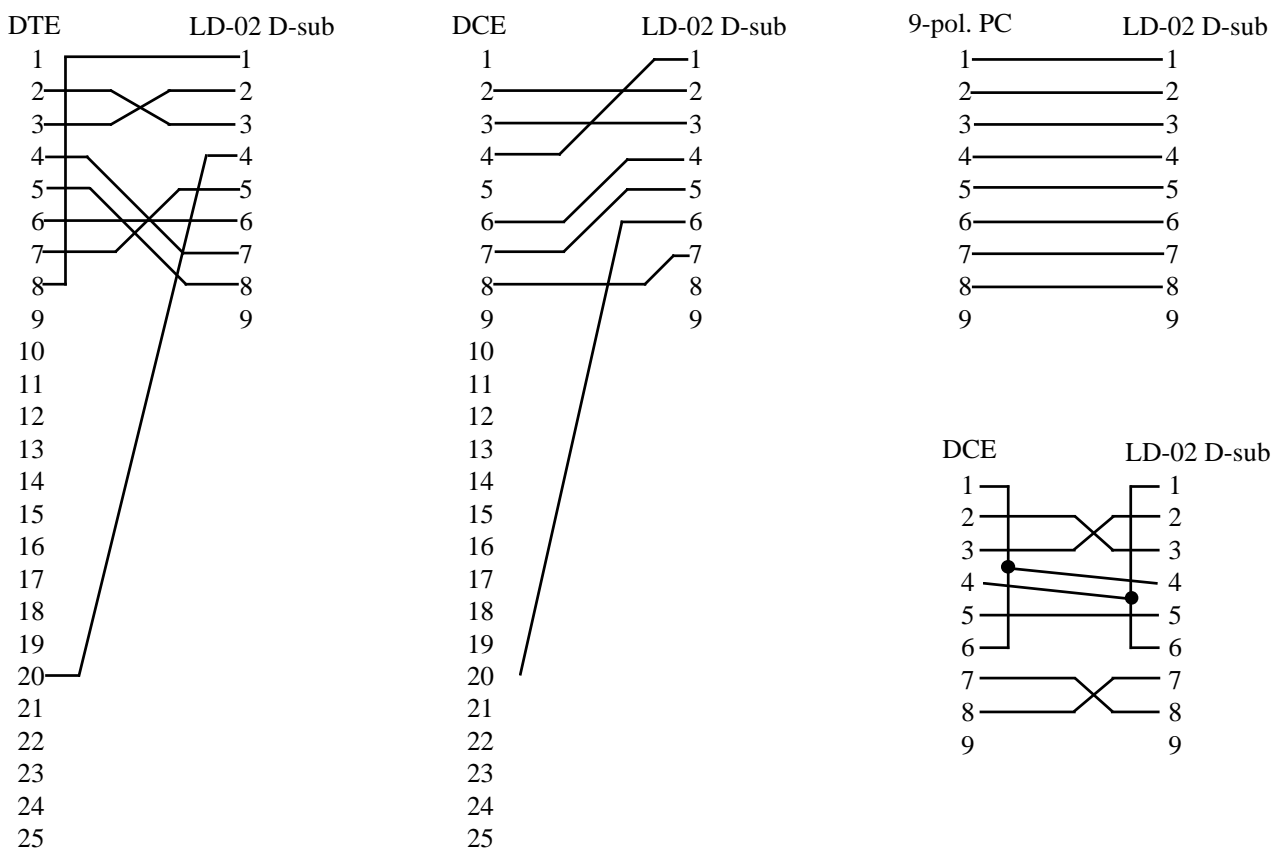

Specifications LD-02 AC

Transmission	Asynchronous, full/half duplex or simplex
Interface 1	EIA RS-232-C/V.24 fixed on channel 1
Interface 2	10mA balanced current loop fixed on channel 2 and 3
Interface 3	EIA RS-422/485/CCITT V.11 on channel 4
Connection	Channel 1: 9 pin D-sub female Channel 4: 5 pos screw-terminal Channel 2 and 3: 9 pos screw-terminal
Max. recommended no of LD-02's in series	14 pcs
Transmission rate	Data rates up to 38 400 bit/s
Indicators	Power, RD, TD, DCD2, DCD3
Isolation	Galvanic isolation with opto-coupler (data transmission) and transformer (supply)
Isolation voltage	1500V
Overvoltage protection	Mains: Breakdown voltage 430V at 230V AC Interface 2: Breakdown voltage transmitter 15V, receiver 5.8 V. Surge capacity 0.6 kW during 1 ms Interface 3: Breakdown voltage receiver and transmitter 7V. Surge capacity 0.6 kW during 1 ms
Power supply	230V 48-62Hz +15/-10%
Fuse	100mA fast .2x.8 inch
Power consumption**	Max 25mA at 230V
Temperature range	5-50°C, ambient temperature
Humidity	0-95% RH, non-condensing
Dimension	2.2x3.9x5 in.
Weight	0.4 kg
Mounting	On 1.4 in. DIN-rail

Specifications LD-02 AC 115V*

Overvoltage protection	Mains: Breakdown voltage 220V at 115V AC
Power supply	115V AC +15/-10% 48-62Hz
Power consumption	Max 50mA at 115V

Specifications LD-02 DC*

Power supply	12-36V DC
Power consumption	Max 3W
Isolation	500V
Fuse FI	1.6A fast acting .2x.8 in.

* All other specifications according to LD-02 AC

** For other power supply voltages contact Westermo

Description LD-02

The LD-02 is primarily designed to be used as a line splitter but it can also be used as an interface converter between Westermo's 10 mA balanced current loop (WI) and RS-232 or RS-422/485.

The LD-02 line splitter has four channels where channel no 1 is RS-232, channel 2 and 3 are WI and Channel 4 is RS-422/485. Each LD-02 will in addition to splitting the WI in RS-232 or RS-422/485 amplify the WI signal (repeater function) allowing a multidrop network with a maximum of 14 LD-02's in series.

The LD-02 offers total galvanic isolation between the interfaces.

The RS-232 and RS-422/485 interfaces are connected in parallel meaning they can't be used simultaneously.

The LD-02 is typically used to extend the RS-422/485 in a multidrop network.

At 9 600 bit/s a maximum distance of 2 500 m can be achieved between each LD-02.

Switch settings

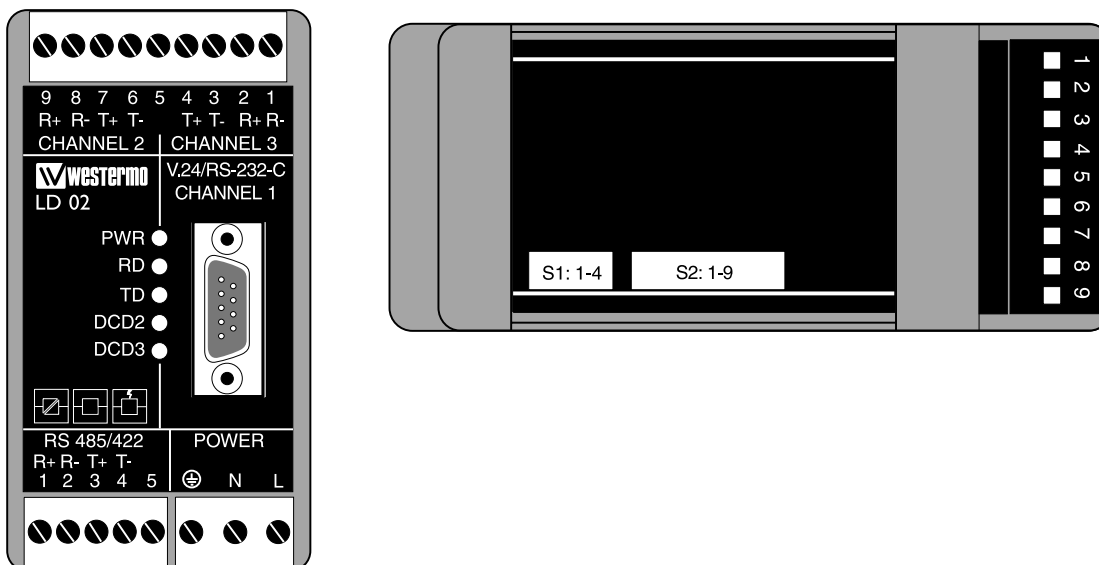

The operating parameters can be set via dip switches located under the lid on top of the plastic case.

WARNING! DO NOT OPEN CONNECTED UNIT



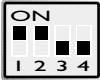

Switch settings



Termination with fail-safe

- S1  Termination 4-wire (RS-422)
- S1  Termination 2-wire (RS-485)
- S1  No termination







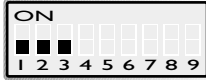

Selection of data bits

- S2  9
- S2  10
- S2  11
- S2  12

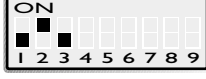

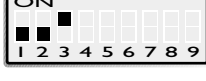
Selection 2/4 wire

- S2  2-wire
- S2  4-wire



Speed

	Selection of speed	Turn around time (max)
S2	 300	3.33 ms
S2	 600	1.67 ms
S2	 1200	833 μ s
S2	 2400	417 μ s
S2	 4800	208 μ s
S2	 9600	104 μ s
S2	 19200	52 μ s
S2	 38400	26 μ s

V or Y function

- S2  Y
- S2  V

Factory settings

- S1  S2 

Data bit selection table

7 bits	•	•	•		•			
8 bits				•		•	•	•
No parity	•	•		•		•		
Parity			•		•		•	•
1 stop bit	•		•	•			•	
2 stop bit		•			•	•		•
Number of bits	9	10	10	10	11	11	11	12

Connections

RS-232 (channel 1)

Direction DCE	Circuit no. 9-pin D-sub	CCITT V.24 Circuit no.	Signal name
O	1	109	DCD/Data Carrier Detect
O	2	104	RD/Received Data
I	3	103	TD/Transmitted Data
I	4	108/2	DTR/Data Terminal Ready
-	5	102	SG/Signal Ground
O	6	107	DSR/Data Set Ready
I	7	105	RTS/Request To Send
O	8	106	CTS/Clear To Send
NC	9		

I=input O=output. The LD-02 is a DCE (Data Communication Equipment).
NC=not connected.

WI, balanced 10mA (channel 2 and 3)

Direction	Circuit no.		Description
	Channel 2	Channel 3	
Receiver	9	2	R+
Receiver	8	1	R-
Transmitter	7	4	T+
Transmitter	6	3	T-
	5	5)Shield

RS-485/422 (channel 4)

Direction	Circuit no.	CCITT V.11 Description
Receiver	1	A' (R+)
Receiver	2	B' (R-)
Transmitter	3	A (T+)
Transmitter	4	B (T-)
	5)Shield

RS-485/422 connection (channel 4)

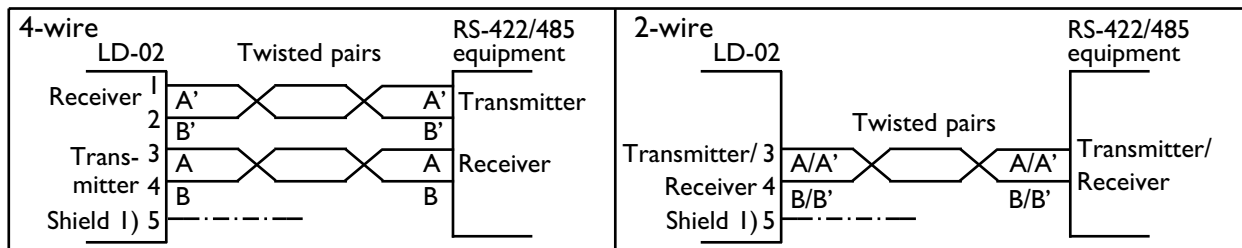

1) If shielded cable is used, connect the shield only at one end to avoid ground loop currents.

Power connection LD-02 AC 3 position screw-terminal

Connection no.	Power supply
L	115*/230V AC power
N	
	PE, Protective Earth

Power connection LD-02 DC 2 position screw-terminal

Connection no.	Power supply
1	-Voltage
2	+Voltage

* LD-02 115V

Transmission range (10mA balanced current loop WI)

Cable	Transmission data rate bit/s						
	600	1200	2400	4800	9600	19200	38400
42pF/m 0,3mm ²	18000m	12000m	8000m	5000m	2500m	1000m	500m

Hints

The drop channels (no. 1 and 4) are configured as DCE (Data Communication Equipment). Most printers, PC's and terminals are set as DTE (Data Terminal Equipment). A recommendation of cable configurations is given below.

If any problems do occur on set up of the LD-02:s, the LED's will be helpful.

- PWR: The unit has power.
- RD: Indicates transmitted data from channel 1 or 4
- TD: Indicates received data on channel 1 or 4
- DCD2: Indicates carrier on channel 2
- DCD3: Indicates carrier on channel 3

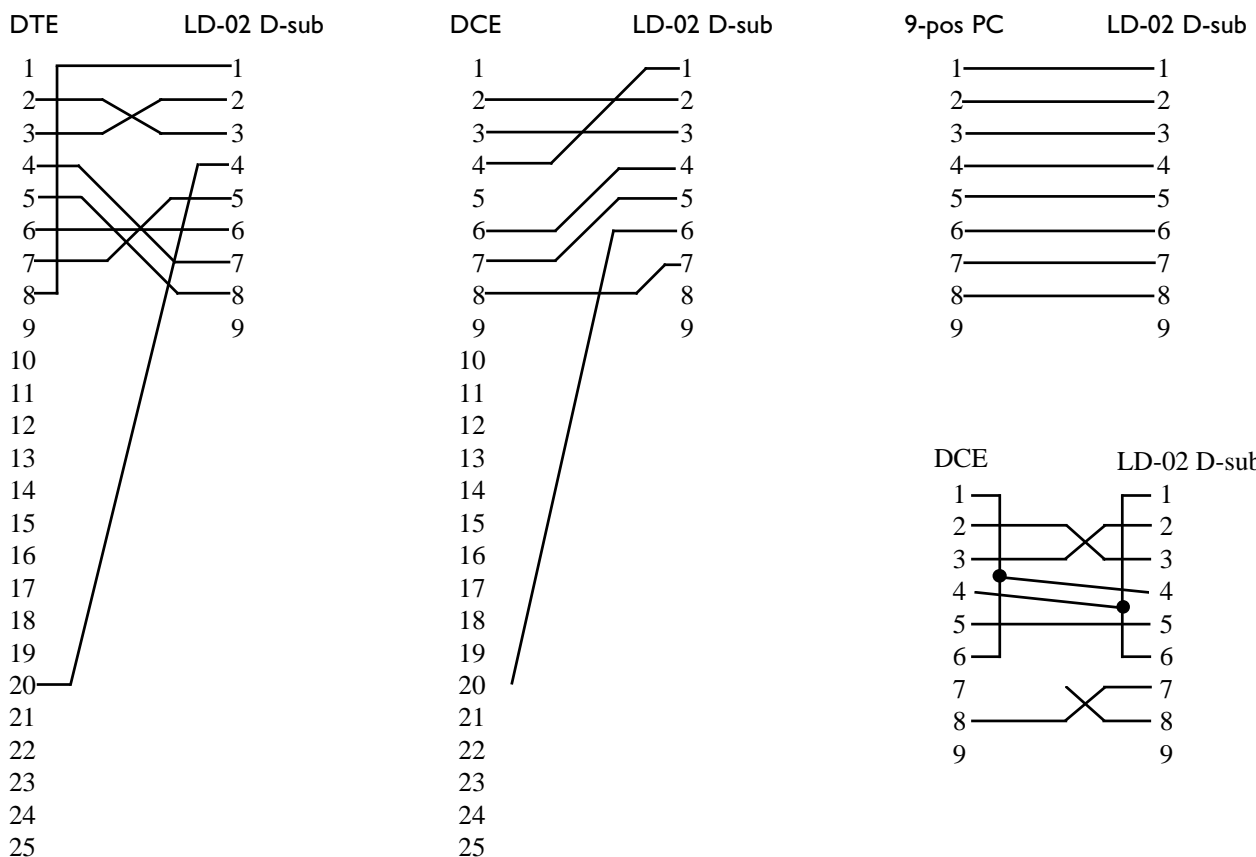

Technische Daten LD-02AC

Übertragungsarten	Asynchron, Voll-/Halbduplex oder Simplex
Schnittstelle 1	EIA RS-232-C/V.24 auf Kanal 1
Schnittstelle 2	10mA Symmetrische Stromschleife auf Kanal 2 und 3
Schnittstelle 3	RS-485/422 auf Kanal 4
Anschlüsse	Kanal 1: 9 polige Sub-D Buchse Kanal 4: 5 polige Schraubklemme Kanal 2 und 3: 9 polige Schraubklemme
Max. Anzahl in Reihe geschalteter Geräte	14 St.
Übertragungsraten	Bis zu 38 400Bit/s
Leuchtdioden	Betrieb, TD, RD, DCD2, DCD3
Isolation	Galvanisch Isoliert mittels Optokoppler (Datenübertragung) und Transformator (Spannungsversorgung)
Isolationsspannung	1500V
Überspannungsschutz	Netz: Durchbruchspannung 430V bei 230V AC Schnittstelle 2: Durchbruchspannung Sender 15V und Empfänger 5,8V. Stromstoßkapazität 0,6 KW/1mS Schnittstelle 3: Durchbruchspannung Empfänger und Sender 7V. Stromstoßkapazität 0,6 KW/1mS
Spannungsversorgung	230V +15/ -10% 48-62 Hz
Sicherung	100mA .2x.8 inch flink
Leistungsaufnahme	Max. 25mA bei 230V
Umgebungstemperatur	41-122°F
Luftfeuchtigkeit	0-95%, nicht kondensierend
Abmessungen	2.2x3.9x5 in.
Gewicht	0,4 Kg
Installation	auf 1.4 in, Din-Schiene

Technische Daten LD-02 AC 115V*

Überspannungsschutz	Netz: Durchbruchspannung 220V bei 115V AC
Spannungsversorgung	115V AC +15/ -10% 48-62 Hz
Leistungsaufnahme	max. 50mA bei 115V

Technische Daten LD-02 DC

Spannungsversorgung	12-36V DC
Leistungsaufnahme	Max 3W
Isolationsspannung	500V
Sicherung FI	1,6A .2x.8 in. flink
Dip-Schalter Einstellungen	Siehe LD-02AC
Anschlüsse	Siehe LD-02AC außer Spannungsversorgung

* Alle anderen Daten siehe LD-02AC ** Weitere Varianten auf Anfrage

Beschreibung LD-02

Das LD-02 wurde in erster Linie als Leitungsteiler entwickelt, kann aber auch als Schnittstellen Konverter, von Westermo's 10mA Stromschleife (WI) auf RS-232 oder RS-422/485, benutzt werden.

Das LD-02 besitzt 4 Kanäle. Kanal 1 ist eine RS-232 Schnittstelle und Kanal 2 & 3 sind WI Schnittstellen. Kanal 4 ist eine RS-422/485 Schnittstelle. Jedes LD-02 kann zusätzlich zur WI Leitungsteilung, in RS-232 und RS-422/485, noch das WI Signal verstärken (Repeater Funktion) und Mehrpunktnetzwerke mit bis zu 14 in Reihe geschalteten LD-02's aufbauen. Das LD-02 ist zwischen den Schnittstellen komplett galvanisch Isoliert. Die RS-232 und RS-422/485 Schnittstellen sind parallel geschaltet, somit ist eine gleichzeitige Nutzung nicht möglich. Das LD-02 wird benutzt um ein RS-422/485 Netzwerk zu erweitern. Bei einer 9600 Bit/s Kommunikation beträgt die maximale Strecke zwischen zwei Geräten 2500m.

DIP-Schalter Einstellung

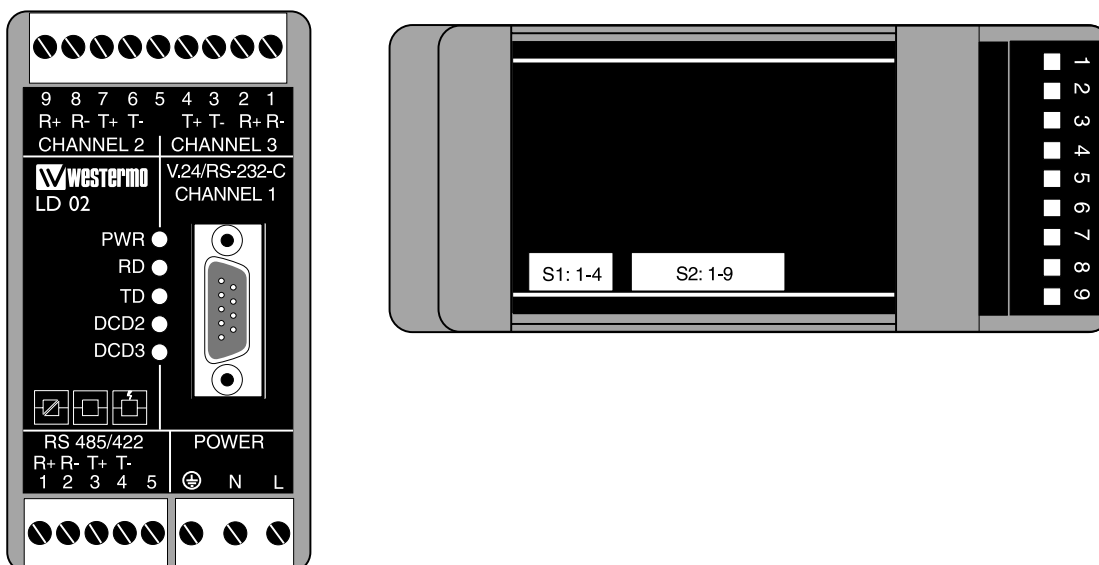

Das LD-02 bietet verschiedene Einstellmöglichkeiten zur Abstimmung auf verschiedenste Betriebsverhältnisse. Um die DIP-Schalter einzustellen muß die Gehäuseabdeckung z.B. mit Hilfe eines Schraubendrehers abgenommen werden.

ACHTUNG! ANGESCHLOSSENE GERÄTE NICHT ÖFFNEN





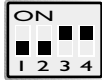



DIP Schalter Einstellung



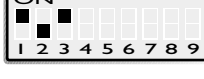

Terminierung mit Fail-Safe

- SI  4-Draht Terminierung(RS-422)
- SI  2-Draht Terminierung(RS-485)
- SI  keine Terminierung

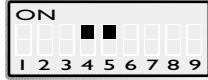

Geschwindigkeit

	Leitungs- geschwindig- keit	Umschalt- zeit
S2 	300	3,33 ms
S2 	600	1,67 ms
S2 	1200	833 µs
S2 	2400	417 µs
S2 	4800	208 µs
S2 	9600	104 µs
S2 	19200	52 µs
S2 	38400	26 µs



Einstellung der Datenbits

- S2  9
- S2  10
- S2  11
- S2  12



2-/4-Draht Betrieb

- S2  2-Draht
- S2  4-Draht

V oder Y Betrieb

- S2  Y
- S2  V

Werkseinstellung

- SI  S2 

Übersicht für Datenbit Einstellung

7 Bit	•	•	•		•			
8 bit				•		•	•	•
Keine Parität	•	•		•		•		
Parität			•		•		•	•
1 Stop Bit	•		•	•			•	
2 Stop Bits		•			•	•		•
Anzahl der Bits	9	10	10	10	11	11	11	12

Anschlüsse

RS-232 (kanal 1)

Richtung DCE	PinNr. 9-pol D-sub	CCITT V.24 Bezeichnung	Beschreibung
O	1	109	DCD / Data Carrier Detect
O	2	104	RD / Received Data
I	3	103	TD / Transmitted Data
I	4	108/2	DTR / Data Terminal Ready
-	5	102	SG / Signal Ground
O	6	107	DSR / Data Set Ready
I	7	105	RTS / Request to Send
O	8	106	CTS / Clear to Send
NV	9		

I= I Eingang O= Ausgang. LD-02 ist eine DÜE (Daten Übertragungs Einrichtung).
NV = nicht Verbunden

WI, 10mA Stromschleife (Kanal 2 & 3)

Richtung	Klemme Nr.		Beschreibung
	Kanal 2	Kanal 3	
Empfänger	9	2	R+
Empfänger	8	1	R-
Sender	7	4	T+
Sender	6	3	T-
	5	5	¹⁾ Schirm

RS-485/422 (Kanal 4)

Richtung	Klemme Nr.	CCITT V.11 Bezeichnung
Empfänger	1	A' (R+)
Empfänger	2	B' (R-)
Sender	3	A (T+)
Sender	4	B (T-)
	5	¹⁾ Schirm

Leitungsanschluß:

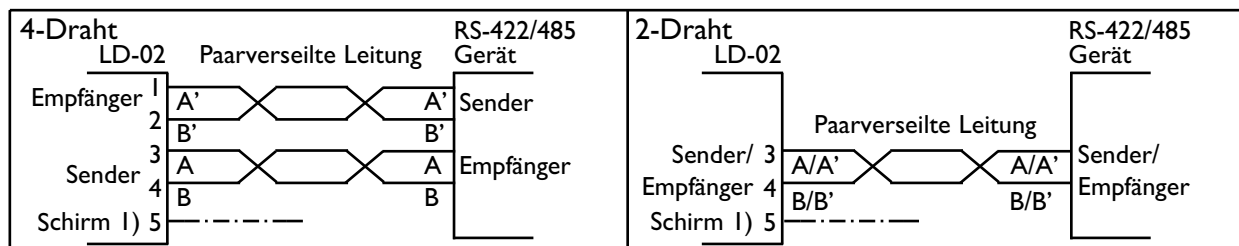

1) Bei Verwendung von abgeschirmten Kabeln den Schirm nur auf einer Seite anschließen um Erdströme zu vermeiden

Spannungsversorgung LD-02 AC 3-polige Schraubklemme

Klemme Nr.	Spg.-Versorgung
L	115*/230V
N	AC Anschluß
	PE, Schutzterde

Spannungsversorgung LD-02 DC 2-polige Schraubklemme

Klemme Nr.	Spg.-Versorgung
1	-Pol
2	+Pol

* LD-02 115V

Übertragungsweiten 10mA symmetrische Stromschleife WI

Leitung	Übertragungsgeschwindigkeit						
	600	1200	2400	4800	9600	19200	38400
42pF/m 0,3mm ²	18000m	12000m	8000m	5000m	2500m	1000m	500m

Tips

Die Schnittstellen 1 & 4 sind als DÜE (Daten Übertragungs Einheit) konfiguriert.
Die meisten Drucker, PC's und Terminals sind DEE's (Daten Endeinrichtungen).
Beispiele für Kabelbelegungen werden unten aufgeführt.

Bei Problemen mit der Einstellung des LD-02 können die LED's hilfreich sein

- PWR Das Gerät hat Versorgungsspannung
- RD Daten Sendung an Kanal 1 oder 4
- TD Daten Empfang an Kanal 1 oder 4
- DCD2 Träger Anzeige für Kanal 2
- DCD3 Träger Anzeige für Kanal 3

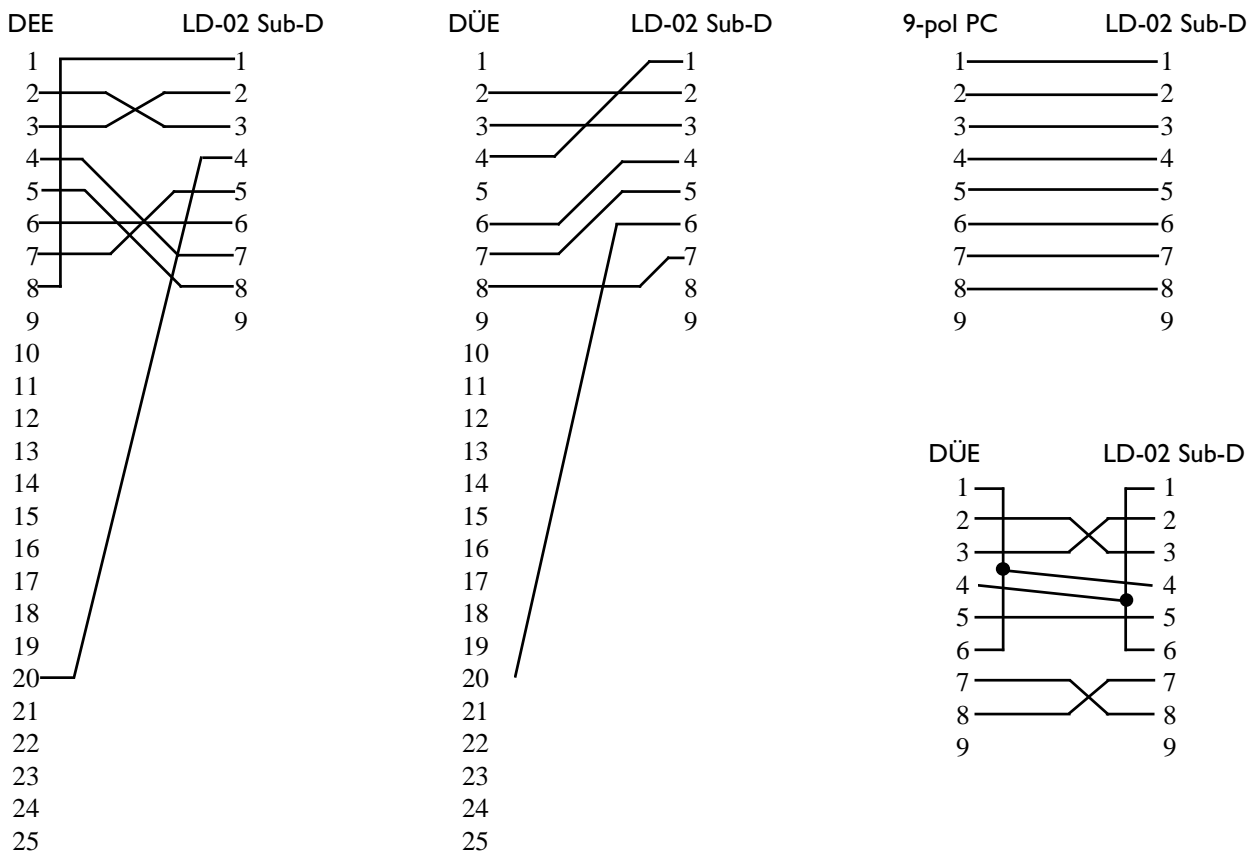

Block diagram

