

FD-40

# INSTALLATION MANUAL

6630-2242

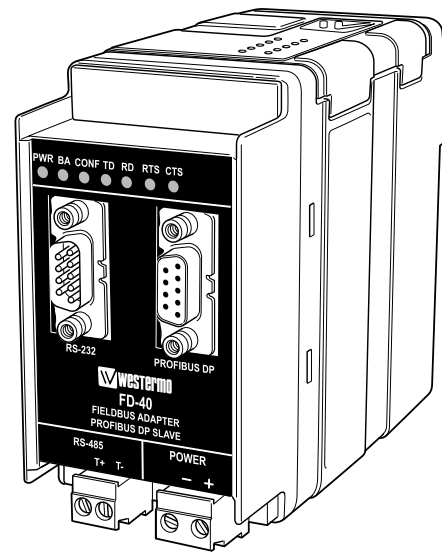

*Fieldbus Converter*

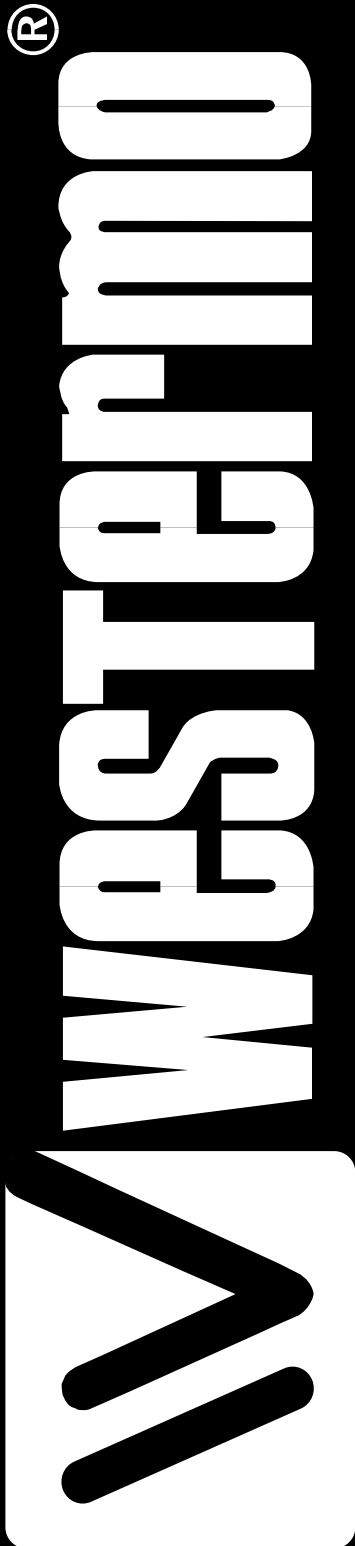

[www.westermosales.com](http://www.westermosales.com)



# Contents

<b>1. Safety</b> .....	<b>4</b>
<b>2. Approvals</b> .....	<b>4</b>
2.1. Declaration of Conformity .....	5
<b>3. Introduction</b> .....	<b>6</b>
3.1 Field of application .....	6
<b>4. Specifications</b> .....	<b>7</b>
4.1 Interfaces .....	7
4.2 Insulation between interfaces .....	8
4.3 Climatic environment .....	8
4.4 Mechanics .....	8
<b>5. Maintenance</b> .....	<b>9</b>
<b>6. Installation</b> .....	<b>9</b>
6.1 Mounting /Removal .....	9
6.2 Connections .....	12
6.2.2 Power .....	10
6.2.3 PROFIBUS DP .....	11
6.2.4 RS-232 (DTE) .....	11
6.2.5 RS-485 .....	11
6.3 Indicators .....	12
6.3.1 LED indicators .....	12
6.4 Configuration .....	12
6.4.1 DIP switch settings .....	12–13
6.4.2 On-line configuration by FD-Tool .....	14
6.4.3 Off-line configuration by FD-Tool .....	15
6.4.4 Save, load and modify configuration files by FD-Tool .....	15
<b>7. Functional description</b> .....	<b>16</b>
7.1 Point to point and Addressed, serial transfer slave, FD-10 P .....	16
7.1.1 Basic configuration .....	17
7.1.1.1 Expert configuration .....	17
7.1.2 PROFIBUS DP I/O data .....	17
7.3.2.1 Output data word .....	17–19
7.3.2.2 Input data word .....	19–20
7.3.2.3 PROFIBUS DP communication .....	21–22

# 1. Safety



## **General:**

Before using this unit, read this manual completely and gather all information on the unit. Make sure that you understand it fully. Check that your application does not exceed the safe operating specifications for this unit.



## **Before installation, maintenance or modification work:**

Prevent damage to internal electronics from electrostatic discharges (ESD) by discharging your body to a grounding point (e.g. use of wrist strap).

Prevent access to hazardous voltages by disconnecting the unit from AC/DC mains supply and all other electrical connections.



## **Installation:**

This unit should only be installed by qualified personnel.

This unit should only be installed in a "restricted access area", for example a lockable cabinet where access is restricted to service personnel only.

This unit is intended for permanent connection to the AC/DC mains supply.

The power supply wiring must be sufficiently fused, and if necessary it must be possible to disconnect manually from the AC/DC mains supply. Ensure compliance to national installation regulations.

Unit with the rated voltage exceeding 42.4 V peak or 60 VDC, is defined as class I equipment with a protective earthing conductor terminal.

Unit with the rated voltage up to 42.4 V peak or 60 VDC, is defined as class III equipment and shall be separated from hazardous voltage by double or reinforced insulation.

This unit uses convection cooling. To avoid obstructing the air flow around the unit, follow the spacing recommendations (see under chapter Installation).

# 2. Approvals

Conformity with the Directive 89/339/EEC (Electromagnetic compatibility) has been assessed by application of standards EN 61000-6-2 (industrial immunity) and EN 61000-6-4 (industrial emission).

## 2.1. Declaration of Conformity

Westermo Teleindustri AB

### Declaration of conformity

The manufacturer Westermo Teleindustri AB  
SE-640 40 Stora Sundby, Sweden

herewith declares that the product(s)

Type of product	Model	Art no	Installation manual
DIN-rail Fieldbus adapter	FD-10 P	3630-1100	6630-2212
	FD-10 A	3630-1101	
	FD-10 N	3630-1102	
DIN-rail Fieldbus converter	FD-40	3630-1400	6630-2242

is in conformity with the following EC directive(s).

No	Title
89/336/EEG	Electromagnetic Compatibility (EMC-directive)

References of standards applied for this EC declaration of conformity.

No	Title	Issue
EN 61000-6-2	Immunity for industrial environments	2 (2001)
EN 61000-6-4	Emission standard for industrial environments	1 (2001)



Hans Levin  
Technical Manager  
26th May 2003

---

Postadress/Postal address  
S-640 40 Stora Sundby  
Sweden

Tel.  
016-61200  
Int+46 1661200

Telefax  
016-61180  
Int+46 1661180

Postgiro  
52 72 79-4

Bankgiro  
5671-5550

Org.nr/  
Corp. identity number  
556385-6367

State  
Registered office  
Eskilstuna

### 3. Introduction

The FD-40 Fieldbus Converter integrates devices using the serial interfaces RS-232 or RS-485 into PROFIBUS DP.

The FD-40 works as a PROFIBUS DP slave and enables the utilisation of normal PROFIBUS DP I/O data for transparent communication over a serial interface.

The FD-40 enables the integration of systems such as measuring devices, electronic scales, operator terminals, printers, identification systems, barcode readers and other automation devices which use a RS-232 or RS-485 interface into PROFIBUS DP applications. While FD-40 have 15 kbyte input and output buffers, a huge amount of data or a high data rate can be transferred over the serial interface without disturbing the PROFIBUS DP traffic.

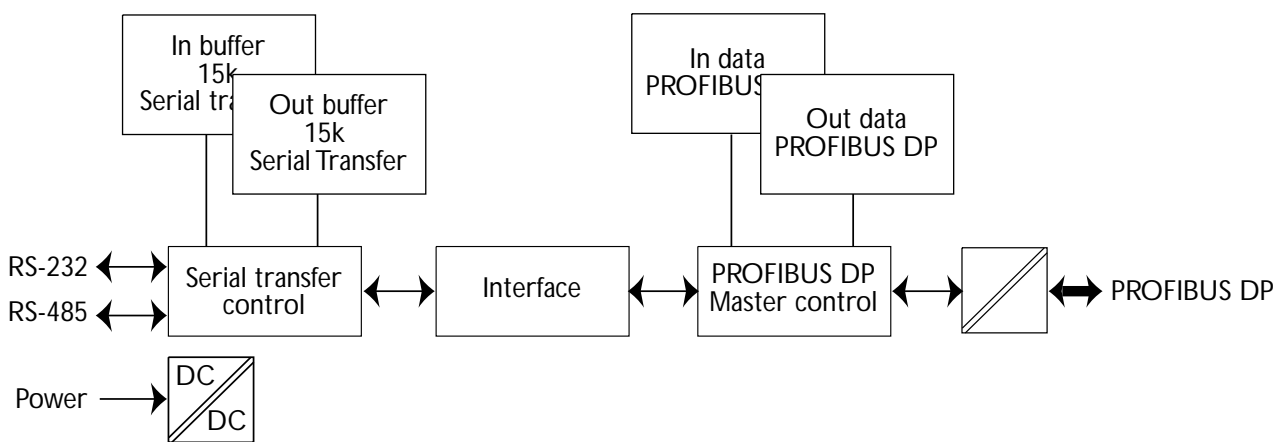

#### 3.1 Field of application

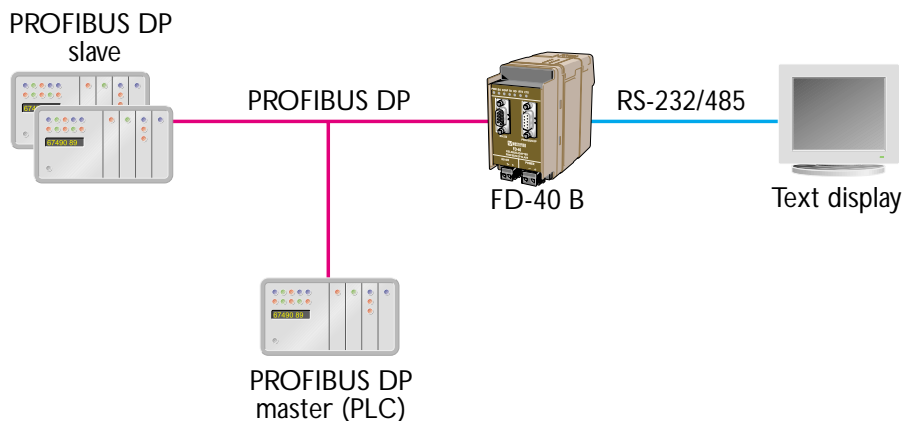

- Receive data from bar code readers
- Interface to operator terminals
- Send data to viewing screens
- Interface to transmitters with serial interface

## 4. Specifications

### 4.1 Interfaces

#### Power

Rated voltage	12–48 VDC
Operating voltage	9.6–57.6 VDC
Rated current	250 mA @ 12 V, 120 mA @ 24 V, 60 mA @ 48 V
Rated frequency	DC
Polarity	Reverse polarity protected
Connection	Screw terminal
Connector size	0.2–2.5 mm <sup>2</sup> (AWG 24–12)
Fuse	To be externally fused

#### PROFIBUS DP

Electrical specification	RS-485/V.11 / EN 50 170
Data rate	9.6, 19.2, 45.45, 93.75, 187.5, 500, 1 500, 3 000, 6 000 and 12 000 kbit/s
Connection	9-position D-sub (female)
Termination	External
Circuit type	TNV-1

#### RS-485

Electrical specification	RS-485/V.11
Data rate	1 200, 2 400, 4 800, 9 600, 14 400, 19 200 and 38 400 bit/s
Data format	7/8 data bits, no/odd/even parity, 1/2 stop bits
Connection	2-position screw terminal
Connector size	0.2 – 2.5 mm <sup>2</sup> (AWG 24-12)
Circuit type	TNV-1

#### RS-232

Electrical specification	RS-232/V.24
Data rate	1 200, 2 400, 4 800, 9 600, 14 400, 19 200 and 38 400 bit/s
Data format	7/8 data bits, no/odd/even parity, 1/2 stop bits
Connection	9-position D-sub, DTE
Circuit type	SELV

## 4.2 Insulation between interfaces

<b>Power to all other</b>	1.0 kV RMS @ 50Hz and 60 s duration
<b>PROFIBUS DP to all other</b>	1.0 kV RMS @ 50Hz and 60 s duration

Please note that there is no galvanic isolation between the RS-232 and the RS-485 ports so they should not be connected simultaneously.

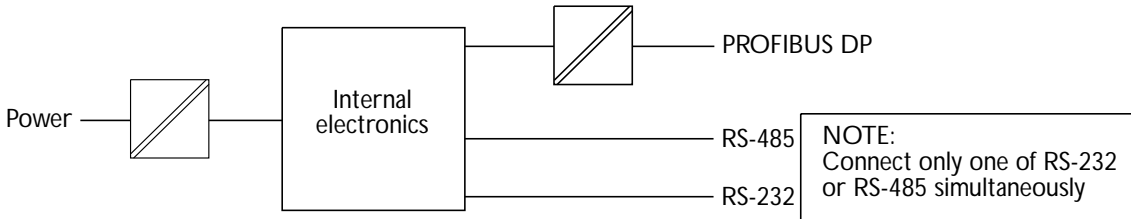

## 4.3 Climatic environment

<b>Temperature, operating</b>	+41 to +131°F (optional industrial -13 to +158°F)
<b>Temperature, storage and transportation</b>	-13 to +158°F
<b>Relative humidity, operating</b>	5 to 95% (non-condensing)
<b>Relative humidity, storage and transportation</b>	5 to 95% (condensation allowed outside packaging)

## 4.4 Mechanics

<b>Dimension (W x H x D)</b>	2.2 x 3.9 x 5.2 in.
<b>Weight</b>	0.3 kg
<b>Mounting</b>	1.4 in. DIN-rail
<b>Degree of protection</b>	IP 20 (IEC 529)

## 5. Maintenance

No maintenance is required, as long as the unit is used as intended within the specified conditions.

## 6. Installation

### 6.1 Mounting /Removal



#### Before mounting or removing the unit:

Prevent damage to internal electronics from electrostatic discharges (ESD) by discharging your body to a grounding point (e.g. use of wrist strap).

Prevent access to hazardous voltages by disconnecting the unit from AC/DC mains supply and all other electrical connections.

#### Mounting

This unit should be mounted on 1.4 in. DIN-rail which is horizontally mounted on a wall or cabinet backplate.

This unit uses convection cooling. To avoid obstructing the air flow around the unit, use the following spacing rules.

Minimum spacing 25 mm (1.0 inch) above/below and 10 mm (0.4 inches) left/right the unit.

Snap on mounting, see figure.

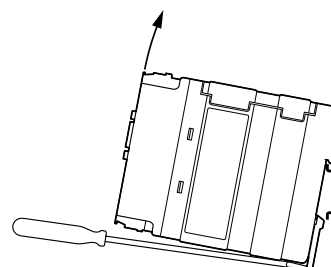
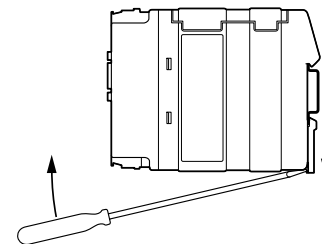
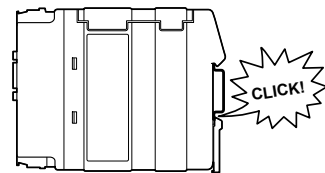
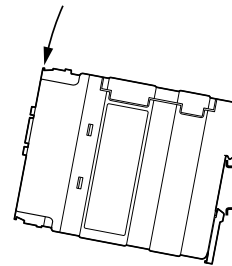
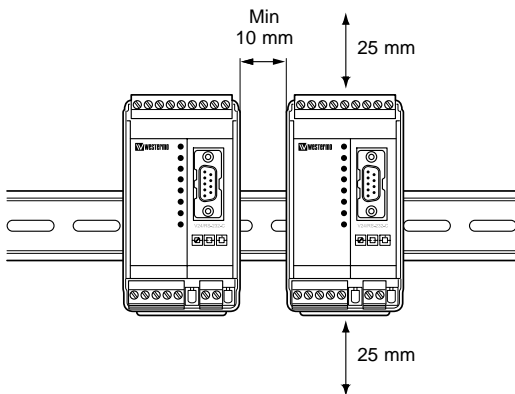

#### Removal

Press down the black support at the back of the unit using a screwdriver, see figure.

# 6.2 Interfaces

RS-232

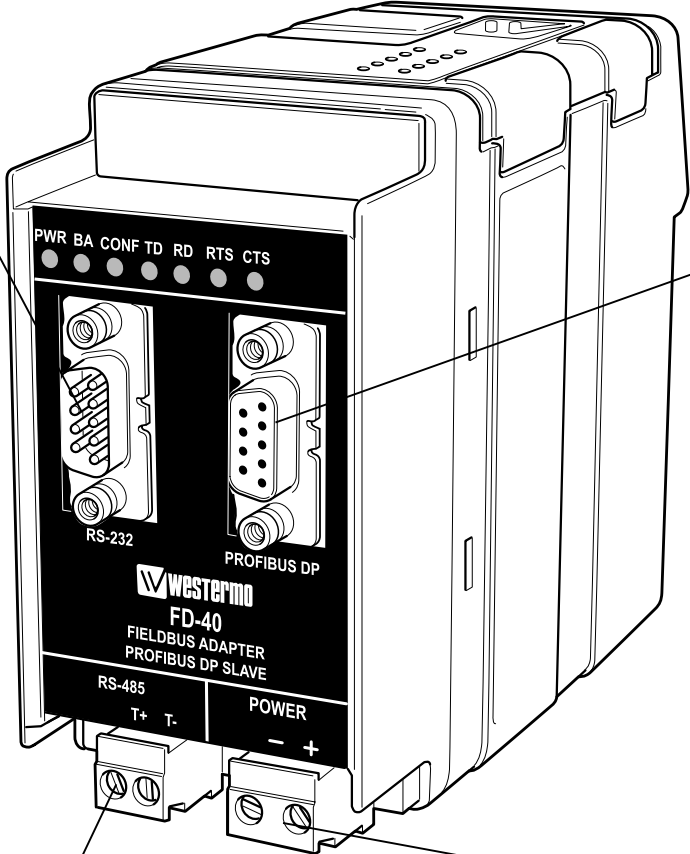

PROFIBUS DP

RS-485

Power

## 6.2.2 Power

2-pos screw terminal	Direction	Description
No. 1	-	0V DC (-)
No. 2	+	+12 to +48 VDC (+)



## 6.2.3 PROFIBUS DP

9-pos D-sub	Direction	Description
No. 1	-	-
No. 2	-	-
No. 3	In/Out	RxD/TxD-P
No. 4	Out	CNTR-P
No. 5	-	DGND
No. 6	Out	VP
No. 7	-	-
No. 8	In/Out	RxD/TxD-N
No. 9	-	DGND

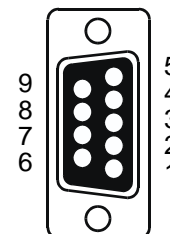

Female

## 6.2.4 RS-232 (DTE)

9-pos D-sub	Direction	Description
No. 1	-	-
No. 2	In	Receive Data (RD)
No. 3	Out	Transmit Data (TD)
No. 4	Out	Data Terminal Ready (DTR)
No. 5	-	Signal ground (SG)
No. 6	-	-
No. 7	Out	Request To Send (RTS)
No. 8	In	Clear To Send (CTS)
No. 9	-	-

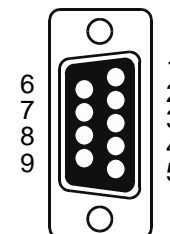

Male

## 6.2.5 RS-485

2-pos screw terminal	Direction	Description
No. 1	In/Out	Transmit/Receive T/R+ (T+)
No. 2	In/Out	Transmit/Receive T/R- (T-)



## 6.3 Indicators

### 6.3.1 LED indicators

<b>PWR</b>	LED on LED off	In service Out of service
<b>BA</b>	LED on LED off	PROFIBUS DP active PROFIBUS DP inactive
<b>CONF</b>	LED on LED off	Configuration mode Normal operation mode
<b>TD</b>	LED on LED off	Transmit serial (RS-232/485) data –
<b>RD</b>	LED on LED off	Receive serial (RS-232/485) data –
<b>RTS</b>	LED on LED off	Request To Send (RTS) set –
<b>CTS</b>	LED on LED off	Clear To Send (CTS) received active –

## 6.4 Configuration

Most of the FD-40 settings have to be carried out by FD-Tool, a PC based configuration software, either on-line or off-line. Only RS-232 or RS-485 transfer settings will be set by DIP switches.

### 6.4.1 DIP switch settings

DIP-switches are accessible under the lid on top of the unit.

 **Warning!** Prevent damage to internal electronics from electrostatic discharges (ESD) by discharging your body to a grounding point (e.g. use of wrist strap), before the lid on top of the modem is removed.

 **Warning!** Do not open connected equipment. Prevent access to hazardous voltages by disconnecting the unit from AC/DC mains supply and all other electrical connections.

**NOTE** The change of DIP switch settings are valid only after a power on.

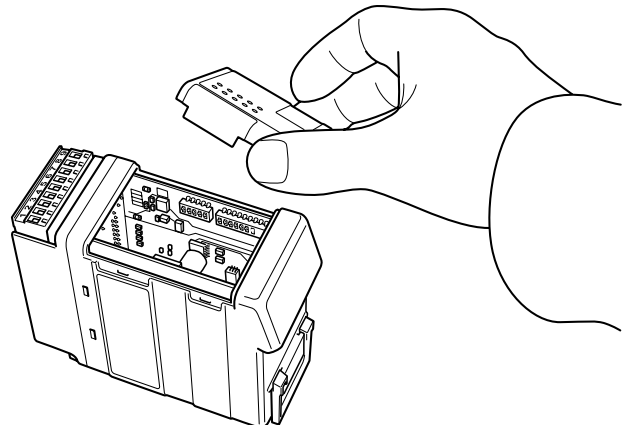

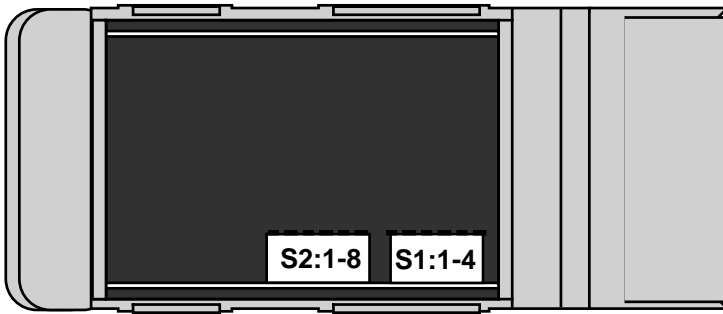

### Switch block 1 Serial transfer setting



No RS-485 termination



RS-232 selected as serial transfer port, data control

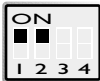

RS-485 terminated by 120 Ω, with fail-safe

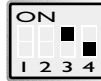

RS-232 selected as serial transfer port, RTS/CTS control

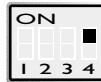

RS-485 selected as serial transfer port

### Factory setting



S1

RS-232 selected as serial transfer port, data control.  
No RS-485 termination

**Note 1:** Configuration by FD-Tool require factory setting (all S1 switches off).

**Note 2:** Switch 2 is not used.

## 6.4.2 On-line configuration by FD-Tool

This part will only describe the usage of FD-Tool to perform an on-line configuration. For FD-Tool installation and general FD-Tool handling, see "FD-Tool installation manual" on the CD, FD-Tool.

The FD-40 goes into configuration mode, a connection with FD-Tool, immediately after a power on. The serial interface is set as follows, and should not be changed.

---

RS-232	9 600 bit/s	no parity	8 data bits	1 stop bit	data control
--------	-------------	-----------	-------------	------------	--------------

---

### Initiate an on-line configuration

- Start the FD-Tool.
- Connect a DTE-DTE serial cable (zero-modem) to the serial port of the PC and the RS-232 port of the FD-40.
- Initiate communication between the FD-Tool and the FD-40 by selecting **Connect > RS-232**. The FD-Tool will attempt to get communication until a successful connection or a manual cancel.
- Power the connected FD-40. The CONF LED of FD-40 will be active and remain so as long as the FD-40 is in configuration mode. After some seconds, the connection will be established and the Status (to left in lower border of FD-Tool window) will be changed from Disconnected to Connected. If the CONF LED will be inactive (after about 3 seconds), the initiation of on-line configuration is failed. If failed, check the serial cable and that all S1 switches are set to off. Power on the device again.
- The FD-Tool shows the device type of this FD-40, present configuration, or the default configuration whether the FD-40 is used for the first time.

### Modify configuration

Configurations are defined per device type, see "Functional description", chapter 7.

FD-40 B    Buffered

### Load configuration to FD-40

- The present configuration, shown by FD-Tool, will be loaded to the FD-40 by selecting **File > Configuration > Load to device**.
- This loaded configuration will be running in normal operation after a new power on and when the CONF LED has been set to inactive.

### 6.4.3 Off-line configuration by FD-Tool

This part will only describe the usage of FD-Tool to perform an off-line configuration. For FD-Tool installation and general FD-Tool handling, see “FD-Tool installation manual.”

#### Initiate a new off-line configuration

- Start the FD-Tool.
- Select the device type by selecting **File > Configuration > New (default / device)** and Select Group in Device Selection window. The selected group has to be the same as the FD-40 device, for which the configuration will be used.
- FD-Tool will show the device type of this FD-40 for which all configuration parameters have to be set.

#### Modify configuration

Configurations are defined per device type, see “Functional description”, chapter 7.

FD-40 B      Buffered

#### Load configuration to FD-40

- See “On-line configuration by FD-Tool”, chapter 6.4.2.

### 6.4.4 Save, load and modify configuration files by FD-Tool

#### Save configuration to disk

- The present configuration can be saved to disk as a file, to be used for future configurations of the same device type, by selecting **File > Configuration > Save to disk**
- An arbitrary file name can be used, saved as a \*.cnf file.

#### Load and modify a disk stored configuration

- Load configuration from disk by selecting **Configuration > Load from disk** and open the wanted configuration file (\*.cnf).
- FD-Tool shows the device type of this FD-40 with the present configuration.

## 7. Functional description

### Technical data

		FD-40 B
<b>Device</b>	Device type	
	GSD-file	FD-10.GSD
<b>PROFIBUS DP data</b>	Device type	Slave
	Address range	0 to 126
	Number of modules	2
	Input data	4 word complete consistency
	Output data	4 word complete consistency
	Data control	One word for serial transfer control

### 7.1 Buffered, FD-40 B

Functions that are included in the FD-40 B:

- 1. Send some bytes of data direct to the serial interface**  
Send up to 6 byte data from PROFIBUS DP to the serial interface
- 2. Send data to buffer and finally send buffered data to the serial interface once**  
Send up to 6 byte PROFIBUS DP data in time to the send buffer. By command can these buffered data be sent to the serial interface. Up to 15 kbyte can be sent once.
- 3. Receive buffered data, from serial interface received data**  
Data received from serial interface will automatically be stored in the receive buffer. These data will be picked up by PROFIBUS DP, 6 byte each time.

All these three functions are ready to use without any modification by the configuration tool.

FD-40 can convert PROFIBUS DP data over the serial interface when the unit is in normal operation mode and the PROFIBUS DP is active, LED CONF inactive and BA active.

## 7.1.1 Basic configuration

### Serial > Serial interface

Select the desired parameters of the Serial interface.

### PROFIBUS-DP > PROFIBUS DP parameters

Profibus DP Address                      Set this FD-40 PROFIBUS DP address.

#### 7.1.1.1 Expert configuration

### PROFIBUS-DP > Expert parameters

Timeout, new                              Set the maximum time as entered PROFIBUS DP in data  
PROFIBUS DP data (ms)                will be seen as new. Default is 500.

ID number                                 Show the ID number of the FD-40. Can't be changed.

### I/O module 1-2 > I/O module 1

Identifier [hex]                         Show the 4 word input Identifier in hex.  
Can't be changed.

### I/O module 1-2 > I/O module 2

Identifier [hex]                         Show the 4 word output Identifier in hex.  
Can't be changed.

## 7.1.2 PROFIBUS DP I/O data

Ordinary 4 word PROFIBUS DP I/O data are used by FD-40, including one data word in and one out for the serial interface control. Additional programming of the PROFIBUS DP master is needed to control I/O data interfacing to the serial port, as defined below.

### 7.3.2.1 Output data word

Data transmitted from PROFIBUS DP master to FD-40. The first word is the command word and the remaining 3 words are ordinary output data to be temporarily stored in the transmit buffer or directly transmitted via the serial interface.

Word	15	High byte						8	7	Low byte						0
1	EN	SDO	SFB	CNF	CTB	OL2	OLI	OL0	RNB	RAK	RBS	-	-	-	-	-
2	Out data byte 1								Out data byte 2							
3	Out data byte 3								Out data byte 4							
4	Out data byte 5								Out data byte 6							

Output word 1 (bit 15...5) are the serial transfer command bits, with the following content:

- EN**            EEnable FD-40 (bit 15).  
This bit must always be set high (1) for normal operation.  
EN bit set to low (0) disable FD-40.
- SDO**          Send actual Data Once, toggle bit (bit 14).  
When this toggle bit change state, the number of output data bytes defined by DL2-DL0 are taken from Profibus DP out data and transmitted directly over the serial interface.
- SFB**          Send data from transmit buffer, toggle bit (bit 13).  
When this toggle bit change state, the content of the transmit buffer will be continuously transmitted over the serial interface. During transmission the Transmission Busy status (TXB) will be set to high (1).  
Write acknowledge status (WAK) will be changed at transmission of the first character.
- CNF**          CoNfiguration mode (bit 12).  
This bit must always be set low (0) for normal operation.
- CTB**          Copy to Transmit Buffer, toggle bit (bit 11).  
When this toggle bit change status, Out data Length (OL2-0) characters of PROFIBUS DP out data (out data 1–6) will be transferred to the transmit buffer. Before change state of CTB, the PROFIBUS DP out data (out data 1–6) and Data Length (OL2-0) must be set.
- OL2**          Out data Length bit 2 (bit 10).  
Bit 2 of the PROFIBUS DP out data length.
- OLI**          Out data Length bit 1 (bit 9).  
Bit 1 of the PROFIBUS DP out data length.
- OL0**          Out data Length bit 0 (bit 8).  
Bit 0 of the PROFIBUS DP out data length.  
E.g. For 6 characters PROFIBUS DP out data OL2, OLI will be high (1) and OL0 low (0).
- RNB**          Read Next Block (bit 7).  
At the low to high transition of this command, the first data block of the receive buffer will be fetched and written into Profibus DP in data. The In data Length (IL2-0) defines the number of fetched characters. The Profibus DP in data is valid when the command is acknowledged by change state of BLock Ready (BLR).  
At the high to low edge of this command, clear the first data block area of the receive buffer and reset the In data Length (IL2-0).
- RAK**          Read AcKnowledge, toggle bit (bit 6).  
This bit will always be set low (0) for normal operation.  
Only used when compatibility with earlier product versions is needed.

**RBS**            Reset Buffers and Status signals (bit 5).  
 At the low to high transition of this command, the receive and transmit buffers and the status signals RBO, TBO and DEX are cleared. The command is acknowledged by change state of BLock Ready (BLR). After state of BLR has been changed, RBS will be set to low (0) again.

Output word 1 (bit 4...0) are not used  
 These bits will always be set to 0.

Output word 2 to 4 is the output data, with following content:

Word 2	High: Out data byte 1	Low: Out data byte 2
Word 3	High: Out data byte 3	Low: Out data byte 4
Word 4	High: Out data byte 5	Low: Out data byte 6

### 7.1.2.2 Input data word

Data is transmitted from the FD-40 to the PROFIBUS DP master. The first word is the added status word and the remaining 3 words are ordinary input data from the receive buffer.

Word	15	High byte						8	7	Low byte						0
1	VAL	TXB	TBO	RBO	DPN	IL2	IL1	IL0	BLR	WAK	ERR	DEX	–	–	–	–
2	In data byte 1								In data byte 2							
3	In data byte 3								In data byte 4							
4	In data byte 5								In data byte 6							

Input word 1 (bit 15...4) are the serial transfer status bits, with following content:

- VAL**            FD-40 VALid (bit 15).  
 Set to high (1) when the FD-40 is in normal operation.  
 Set to low (0) when the receive buffer is full or if data received from serial interface has wrong polarity.
- TXB**            TX Busy (bit 14).  
 Set to high (1) as long as data is transmitted by the serial interface, directly or from the transmit buffer.
- TBO**            Transmit Buffer Overflow (bit 13).  
 Set to high (1) as long as transmit buffer has less than 6 bytes free.
- RBO**            Receive Buffer Overflow (bit 12).  
 Set to high (1) when the receive buffer has less than 15 bytes free.  
 Reset to low (0) when the receive buffer has more than 100 bytes free.

- DPN** PROFIBUS DP New (bit 11)  
Normally not used, but can serve as support for evaluating the age of wanted data.  
Set to high (1) when a data block of the receive buffer has been fetched and written into PROFIBUS DP in data. Automatically reset to low (0) after timeout, the maximum time entered PROFIBUS DP in data will be seen as new. This timeout is set by the parameter "Timeout, new PROFIBUS DP data, by the configuration tool FD-Tool.
- IL2** In data Length bit 2 (bit 10)  
Bit 2 of the PROFIBUS DP in data length.
- IL1** In data Length bit 1 (bit 9)  
Bit 1 of the PROFIBUS DP in data length.
- IL0** In data Length bit 0 (bit 8)  
Bit 0 of the PROFIBUS DP in data length.  
E.g. For 6 characters PROFIBUS DP in data will IL2, IL1 be high (1) and IL0 low (0).
- BLR** Block Ready, toggle bit (bit 7)  
This toggle bit change state, to acknowledge when the command RNB or RRB (and CNF and RAK if any of these are used) have been finished successfully.
- WAK** Write AcKnowledge, toggle bit (bit 6)  
This toggle bit change state, to acknowledge the command CTB, SDO or SFB.
- ERR** ERRor (bit 5)  
Set to high (1) when the last received command or it's parameters were illegal.  
Set to low (0) when receiving a correct command.
- DEX** Data EXist (bit 4)  
Set to high (1) as long as the receive buffer contains data received by the serial interface.  
Reset to low (0) by the command Read Next Block (RNB) when the receive buffer is empty.
- Input word 1 (bit 3...0) are not used.

Input word 2 to 4 is the input data, with following content:

Word 2	High: In data byte 1	Low: In data byte 2
Word 3	High: In data byte 3	Low: In data byte 4
Word 4	High: In data byte 5	Low: In data byte 6

### 7.3.2.3 PROFIBUS DP communication

This describes the required PROFIBUS DP communication sequence from a PROFIBUS DP master to an FD-40 B, to get access and data exchange with the serial interface of FD-40.

#### **Preparing for all type of data exchange:**

1. Enable normal operation by command EN.  
Out word 1, bit 15 set high (1).
2. Check that FD-40 is in normal operating condition by checking status VAL.  
In word 1, bit 15 should be high (1).

#### **Send PROFIBUS DP out data direct (up to 6 byte) to serial interface:**

1. Write PROFIBUS DP out data word 2–4 to be sent from serial interface.  
Out word 2–4.
2. Set Out data length OL2, OLI and OL0.  
Out word 1 bit 10–8.
3. Check that serial interface is ready to transmit, by status TXB.  
In word 1 bit 14 should be low (0).
4. Send actual data once by command SDO.  
Out word 1, change state of toggle bit 14.
5. Wait for acknowledge, by status WAK.  
In word 1, toggle bit 6 shall change state.

#### **Send PROFIBUS DP out data to transmit buffer, and finally send all buffered data to serial interface once:**

1. Reset buffers and status signals by command RBS.  
Out word 1 bit 5, at edge of low to high state.
2. Wait for acknowledge, by status BLR.  
In word 1 toggle bit 7 shall change state.
3. Reset the RBS command.  
Out word 1 bit 5 set to low (0).
4. Check that FD-40 is in normal operation by status VAL.  
In word 1 bit 15 should be high (1).
5. Write Profibus DP out data word 2–4 to be loaded in transmit buffer.  
Out word 2–4.
6. Set Out data length OL2, OLI and OL0.  
Out word 1 bit 10–8.
7. Copy to transmit buffer by command CTB.  
Out word 1, change state of toggle bit 11.
8. Wait for write acknowledge by status WAK.  
In word 1 toggle bit 6 shall change state.
9. Check that last command was correct by status ERR.  
In word 1 bit 5 should be low (0).

10. Check that transmit buffer has at least 6 byte free by status TBO.  
In word 1 bit 13 should be low (0).
11. If more Profibus DP data to transmit buffer, recur to point 5 again.
12. Send buffered data once to serial port by command SFB.  
Out word 1, change state of toggle bit 13.
13. Wait for acknowledge, by status WAK.  
In word 1, toggle bit 6 shall change state.

**Write to Profibus DP in data from Receive buffered data  
(received from serial interface):**

1. Wait for received frame by checking status DEX.  
In word 1, bit 4 should be high (1).
2. Read next to buffer received block by command RNB.  
Out word 1 bit 7, change state from low to high.
3. Wait for acknowledge by status BLR.  
In word 1, toggle bit 7 shall change state.
4. Read In data Length by status IL2, IL1 and IL0.  
In word 1 bit 10-8.
5. If in data length > 0: Read Profibus DP in data word 2–4.  
In word 2–4 high and low byte, totally In data Length bytes.
6. Clear received block and reset In Data Length by command RNB.  
Out word 1 bit 7, change state from high to low.
7. Read next to buffer received block by command RNB.  
Out word 1 bit 7, change state from low to high.
8. Check if more in data blocks by status DEX.  
In word 1, bit 4 should be high (1).
9. IF DEX is high (1), recur to point 3 again.



# Application examples

