

AT Commands
Reference Guide
6618-3202

TDW-33 TD-36, TD-36 485 TR-36

©Westermo Teleindustri AB • 2008

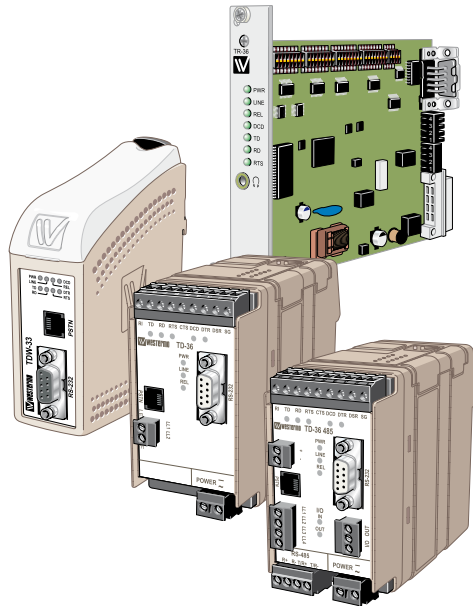

Industrial Telephone Modem



www.westermo.com

Introduction

This document describes the AT-commands that can be used to configure and control the TDW-33,TD-36,TD 36 485 and TR-36 modem.

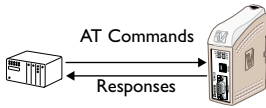

The TDW-33,TD-36,TD-36 485 and TR-36 different operating modes are controlled by AT-commands.

Modem operation modes:

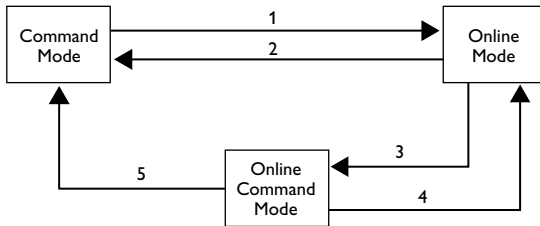

Example of commands/events that can trigger a change of the modems operation modes

- 1 – ATD command
- 2 – Hangup from the remote end
- 3 – Escape sequence +++
- 4 – ATO command
- 5 – ATH command

For more information about Westermo, please visit our website www.westermo.com.

Abbreviations and definitions

Abbreviations

ASCII	American Standard Code for Information Interchange
AT	ATtention; this two-character abbreviation is always used to start a command line to be sent from TE to Modem
BCD	Binary Coded Decimal
ETSI	European Telecommunications Standards Institute
IRA	International Reference Alphabet (ITU-T T.50 [13])
ISO	International Standards Organisation
ITU-T	International Telecommunication Union – Telecommunications Standardization Sector
TE	Terminal Equipment, e.g. a computer (equal to DTE; Data Terminal Equipment)
TIA	Telecommunications Industry Association

Definitions

<CR>	Carriage return character, which value is specified with command S3.
<LF>	Linefeed character, which value is specified with command S4.
<...>	Name enclosed in angle brackets is a syntactical element. Brackets themselves do not appear in the command line.
[...]	Optional subparameter of a command or an optional part of ME information response is enclosed in square brackets. Brackets themselves do not appear in the command line. When subparameter is not given in parameter type commands, new value equals to its previous value. In action type commands, action should be done on the basis of the recommended default setting of the subparameter
<u> </u>	Underlined defined subparameter value is the recommended default setting of this subparameter. In parameter type commands, this value should be used in factory settings that are configured by V.25ter command &F0. In action type commands, this value should be used when subparameter is not given.

List of AT-commands

Commands always start with AT (which means ATtention) and finish with a <CR> character.

Information responses and result codes

Responses normally start and end with <CR><LF>, except when the modem is set to “short result code format” with the command ATV0, or when the ATQ1 (no result codes) command is used.

If command syntax is incorrect, an ERROR string is returned. If extended error result codes are configured (+CMEE) and if command syntax is correct but with some incorrect parameters, the +CME ERROR: <Err> or +CMS ERROR: <SmsErr> strings are returned with different error codes. If the command line has been performed successfully, an OK string is returned. In some cases, such as “AT+CPIN?” or (unsolicited) incoming events, the product does not return the OK string as a response. In the AT-command list below, <CR> and <CR><LF> are intentionally omitted.

Special AT-commands

In addition to the commands listed below there are two special commands that do not start with AT. The first command is “A/” without any <CR>. This command makes the modem repeat the last entered command. The second special command is the “+++” (also without <CR>). This command is called “escape sequence” and is used when the modem is in dedicated mode (online mode). When entering “+++” in dedicated mode, the modem will switch from “online mode” to “online command mode”. This means that it is possible to send commands to the local modem. The escape sequence is useful when disconnecting the active call. The disconnection is made with the ATH command (see the list of AT-commands below). The ATO command can also be used when in “online command mode”.

General commands

The AT command line accepts up to 65 characters.

A – Answer a call

Supported by:	TDW-33	TD-36	TD-36 485	TR-36
---------------	---------------	--------------	------------------	--------------

Description:

The modem will go off-hook and attempt to answer an incoming call if correct conditions are met. Upon successful completion of answer handshake, the modem will go on-line in answer mode.

A successful negotiation must be met during time set by register S7

Syntax:

ATA

Parameters:

No parameters

Command example	Possible responses	Note
ATA	CONNECT<speed>	Answer to this incoming call, call accepted

S register: S7 sets time allowed to connect

&An – Dial Abort Option

Supported by:	TDW-33	TD-36	TD-36 485	TR-36
---------------	---------------	--------------	------------------	--------------

Description:

The modem normally aborts the option the connection negotiation if a character is received from DTE during the connection phase. This command gives the user the option to let the modem ignore characters.

Syntax:

&A<n>

Parameters:

<n>

0: Enables Abort (Default)

1: Disable Abort

Command example	Possible responses	Note
AT&A<n>	OK	The command is valid and accepted
	ERROR	Otherwise

S register: The value is written to S14 bit 4

Bn – ITU-T or BELL

Supported by: TDW-33 TD-36 TD-36 485 TR-36

Description:

When the modem is configured to allow either option, the modem will select Bell or ITU-T modulation for a line speed connection of 300 or 1200 bit/s. Any other line speed will use a ITU-T modulation standard.

Syntax:

B<n>

Parameters:

<n>

0: Selects ITU-T Modulation (Default)

1: Selects Bell Modulation

Command example	Possible responses	Note
ATB<n>	OK	The command is valid and accepted
	ERROR	Otherwise

S register: The value is written to S27 bit 6

\Bn – Transmit Break to Remote

Supported by: TDW-33 TD-36 TD-36 485 TR-36

Description:

In non-error correction mode, the modem will transmit a break signal to to the remote modem with a length in multiples of 100 ms according to parameter specified. The command works in conjunction with the \K command.

Syntax:

\B<n>

Parameters:

<n>

Corresponds to the break length in 100 ms units (Default = 3).

Command example	Possible responses	Note
AT\B<n>	OK	The command is valid and accepted
	ERROR	Otherwise

S register: None

&Bn – DTR/TX Dial Option

Supported by: TDW-33 TD-36 TD-36 485 TR-36

Description:

This command enables the modem to dial a number which is stored with AT&Z0 commands. This is performed when the DTR signal goes from inactive to active signal level or when data is received on the DTE TX line (in command mode).

After enabling the Hotcall functionality the modem must be restarted for the function to take affect. Disable the TX Hotcall function by sending an escape sequence '+++' to enter command mode and then set the &Bn command. See also AT&D and AT&K

Syntax:

&B<n>

Parameters:

<n>

- 0: Disable DTR/TX Hotcall (Default)
- 1: Enable DTR Hotcall
- 2: Enable TX Hotcall (buffered data)

Command example	Possible responses	Note
AT&B<n>	OK	The command is valid and accepted
	ERROR	Otherwise

S register: None

Cn – Carrier control

Supported by: TDW-33 TD-36 TD-36 485 TR-36

Description:

This command is included for compatibility only, and has no effect other than returning a result code.

Syntax:

ATC<n>

Parameters:

<n>

Command example	Possible responses	Note
ATC<n>	OK	The command is valid and accepted
	ERROR	Otherwise

S register: None

%Cn – Select data compression

Supported by: TDW-33 TD-36 TD-36 485 TR-36

Description:

This command enables or disables data compression. The modem can only perform data compression on an error corrected link. The parameter value, if valid, is written to S41 bit 0 and 1.

Syntax:

AT%C<n>

Parameters:

<n>

- 0: No compression. Resets S46 bit 1.
- 1: Enables MNP 5 data compression. Resets S46 bit 1.
- 2: Enables V42bis data compression. Sets S46 bit 1
- 3: Enables both V.42bis and MNP5 data compression. Sets S46 bit 1. (Default)

Command example	Possible responses	Note
AT%C<n>	OK	The command is valid and accepted
	ERROR	Otherwise

S register: The value is written to S41 bits 0 and 1 and S46 bit 1

&Cn – DCD Option

Supported by: TDW-33 TD-36 TD-36 485 TR-36

Description:

This command controls the DCD output in accordance with the parameter supplied

Syntax:

&C<n>

Parameters:

<n>

- 0: DCD remains ON at all times
- 1: DCD follows the state of a carrier (Default)

Command example	Possible responses	Note
AT&C<n>	OK	The command is valid and accepted
	ERROR	Otherwise

S register: The value is written to S21 bit 5

D – Dial command

Supported by: TDW-33 TD-36 TD-36 485 TR-36

Description:

The ATD command is used for data or fax call.

For a data or a fax call, the application sends the following ASCII string to the product:

ATD<nb> where <nb> represents a dial string composed of dial characters and dial modifiers.

The dial characters include the decimal values 0 through 9, letters A,B,C,D, and the symbols “*” and “#”.

Dial modifier description:

Separator	Name	Functionality
,	Commaseparator	Insert a pause in dialing procedure
\$	Bongtoneseparator	A bong tone needs to be detected before dialing continues
;	Returncmdseparator	Return to command state
/	waitseparator	Waits for 0.125 seconds
:	PABX	Wait for PABX tone
+	Insert shortcut	
?	Delimiter	Delimiter between number to be dialed (P#) and PSTN security access password
W	Wait	Wait for dial tone before processing to next character in the dial string
=	Secdialsep.	Wait for second dialtone
&	Wait for credit card dialing tone	Wait for credit card dialing tone before continuing with the dial string. If the tone is not detected within the time specified by S6 or S7, the modem will abort the rest of the sequence, return on-hook, and generate an error message.
@	Quietseparator	Wait for second dialtone
L	RE-dial last dialed number	The L must be immediately after the D with all characters ignored.
P	Select pulse dialing	Pulse dial the numbers that follow until a “T” is encountered.
\	Select pulse dialing	
T	Select Tone dialing	Pulse dial the numbers that follow until a “P” is encountered.
S = n	Dial Stored Number	Dial the number stored in the directory n = 0 to 3
!	Flash	The modem will go on-hook the time specified in S29.

^	Toggle call tone enable/disable	Applicable to current dial only
R		This modifier needs to be accepted, but not acted on
()		Ignored; may be used to format dial string
-		Ignored; may be used to format dial string
<space>		Ignored; may be used to format dial string
<i>		Ignored; may be used to format dial string

Syntax:

ATD<nb>

Response:

The response to the ATD command is one of the following:

Result code	Numeric result code	Description
CONNECT <speed>	Refer to description of result codes	If the call succeeds, for data calls only, <speed> takes the value negotiated by the product
NO CARRIER	3	Call setup failed or remote user release
NO DIALTONE	6	Generate when the modem does not detect a valid dialtone during the dial procedure
BUSY	7	If the called party is already in communication
NO ANSWER	8	If no hang up is detected after a fixed network time-out

Parameters:

<nb> is the dial string

S register: None

&Dn – DTR Control

Supported by: TDW-33 TD-36 TD-36 485 TR-36

Description:

This command controls the Data Terminal Ready (DTR) signal.

Syntax:

AT&D<n>

Parameters:

<n>

- 0: The DTR signal is ignored (Default)
- 1: Modem switches from data to command mode when DTR switches from ON to OFF
- 2: Upon DTR switch from ON to OFF, the call is hang up
- 3: DTR drop causes the modem to perform a soft reset.

Command example	Possible responses	Note
AT&D<n>	OK	The command is valid and accepted
	ERROR	Otherwise

S register: The value is written to S21 bits 3 and 4.

En – Echo

Supported by: TDW-33 TD-36 TD-36 485 TR-36

Description:

This command is used to determine whether the modem echoes characters received by an external application (DTE) or not.

Syntax:

ATE<n>

Parameters:

<n>

- 0: Characters are not echoed
- 1: Characters are echoed (Default)

Command example	Possible responses	Note
ATE<n>	OK	The command is valid and accepted
	ERROR	Otherwise

S register: The value is written to S14 bit 1

%En – Enable/Disable Line Quality Monitor and Auto-Retrain or Fallback/Fall Forward

Supported by: TDW-33 TD-36 TD-36 485 TR-36

Description:

Enable/disable Line quality Monitor and Auto-Retrain or Fall back/fall forward. This command controls if the modem automatically monitors the line quality and requests a retrain (%E1) or fall back when line quality is insufficient or a fall forward when line quality is sufficient (%E2). Set S41 bits 2 and 6.

Syntax:

AT%E<n>

Parameters:

<n>

- 0: Disable Line Quality and auto-retrain
- 1: Enable Line Quality and auto-retrain
- 2: Enable Line Quality Monitor and Fallback/Fall Forward / (Default)

Command example	Possible responses	Note
AT%E<n>	OK	The command is valid and accepted
	ERROR	Otherwise

S register: The value is written to S41 bits 2 and 6.

Fn – Select Line Modulation

Supported by: TDW-33 TD-36 TD-36 485 TR-36

This command selects which type of modulation will be used on the phone line. If this parameter is set to something other than F0, the line speed will be fixed. (See also the +MS command)

Syntax:

ATF<n>

Parameters:

<n>

- 0: Selects Auto V8 automatically line speed according to the preference of the remote modem. (Default)
- 1: Selects 300 bit/s, V.21 (if B0 is set) or Bell 103 (if B1 is set).
- 2: Selects V.22 600 bit/s
- 3: Selects V.23, see %Fn for speed.
- 4: Selects V.22 (if B0 is set) or Bell 212A (if B1 is set). 1 200 bit/s.
- 5: Selects V.22bis, 2 400 bit/s,
- 6: Selects V.32bis 4 800 bit/s or V.32 4 800 bit/s.
- 7: Selects V.32bis 7 200 bit/s.
- 8: Selects V.32bis 9 600 bit/s or V.32. 9 600 bit/s.
- 9 : Selects V.32bis 12 000 bit/s.
- 10: Selects V.32bis 14 400 bit/s.
- 14: Selects V.34
- 15: Auto

Command example	Possible responses	Note
ATF<n>	OK	The command is valid and accepted
	ERROR	Otherwise

%Fn –V23 Speed selection

Supported by: TDW-33 TD-36 TD-36 485 TR-36

The direction and speed of forward and backchannels for V23C modulation are set with this command.

Syntax:

AT%F<n>

Parameters:

<n>

- 1: Selects 75Tx/1200Rx
- 2: Selects 1200Tx/75Rx
- 3: Selects 1200Tx/1200Rx. (Default)

Command example	Possible responses	Note
AT%F<n>	OK	The command is valid and accepted
	ERROR	Otherwise

&Fn – Restore Factory Configuration

Supported by: TDW-33 TD-36 TD-36 485 TR-36

Description:

The modem loads factory default configuration (profile). A configuration (profile) consists of a subset of S-registers.

Syntax:

AT&F<n>

Parameters:

<n>

- 0: Load factory default settings for all commands except Westermo specific commands.
- 1: Load factory default settings for all commands except Westermo specific commands.
- 2: Load factory default for Westermo specific commands.

Command example	Possible responses	Note
AT&F<n>	OK	The command is valid and accepted
	ERROR	Otherwise

S register: None

+FCLASS – Select Active Service Class

Supported by: TDW-33 TD-36 TD-36 485 TR-36

Description:

This command selects the active service class

Syntax

+FCLASS=<n>

+FCLASS?

+FCLASS=?

Parameters

<n>

0: Select Data Mode (Default.)

1: Select Facsimile Class 1

8: Select Voice Mode

Command example	Possible responses	Note
AT+FCLASS<n>	OK	The command is valid and accepted
	ERROR	Otherwise

S register: None

&Gn – Select Guard Tone

Supported by: TDW-33 TD-36 TD-36 485 TR-36

Description:

The modem Generates the guard tone selected by this command according to the parameter supplied (DPSK modulation modes only).

Syntax:

&G<n>

Parameters:

<n>

0: Disables Guard Tone (Default)

1: Disables Guard Tone

2: Selects 1800 Hz Guard Tone.

Command example	Possible responses	Note
AT&G<n>	OK	The command is valid and accepted
	ERROR	Otherwise

S register: The value is written to S23 bits 6 and 7.

*Gn – Password control

Supported by: TDW-33 TD-36 TD-36 485 TR-36

Description:

This command controls whether or not the modem will handle Password and/or Call back functionality.

For compatibility reasons only. See also AT*WCB

Syntax:

*G<n>

Parameters:

<n>

0: Disables Password Control (Default), corresponds to AT*WCB = 0

1: Enables Password Control, corresponds to AT*WCB = 3

Command example	Possible responses	Note
AT*G<n>	OK	The command is valid and accepted
	ERROR	Otherwise

S register: The value is written to S14 bit 6.

+GCI – Country Parameters

Supported by: TDW-33 TD-36 TD-36 485 TR-36

Description:

This command selects the country code for modem.

Syntax:

AT+GCI = <value>

AT+GCI = ?

AT+GCI?

Parameters:

<Value>

Please refer to Country table

i.e.

A5: Selects country code for Sweden

B5: Selects country code for America

C7: Universal country code (Default)

Command example	Possible responses	Note
AT+GCI = <value>	OK	The command is valid and accepted
	ERROR	Otherwise

S register: None

Hn – Disconnect (Hang-Up)

Supported by: TDW-33 TD-36 TD-36 485 TR-36

Description:

This command initiates a hang-up sequence.

Syntax:

ATH<n>

Parameters:

<n>

0: The modem will release the line if the modem currently is on-line.

1: If on-hook, the modem will go off-hook and enter command mode.

Command example	Possible responses	Note
ATH<n>	OK	The command is valid and accepted
	ERROR	Otherwise

S register: None

In – Request identification information

Supported by: TDW-33 TD-36 TD-36 485 TR-36

Description:

This command causes the product to transmit one or more lines of specific information text.

Syntax:

ATI<n>

Parameters:

<n>

- 0: Display max line speed.
- 1: Reserved
- 2: Reserved
- 3: Reserved
- 4: Display manufacturer identification.
- 5: Display country code.
- 6: Display revision identification for modem modulation code
- 7: Reserved
- 8: Display switch settings
- 9: Display Westermo Application Software revision identification.

Other values: "ERROR" string is sent back.

Command example	Possible responses	Note
ATI0	33600 OK	Max line speed
ATI4	WESTERMO TELEINDUSTRI AB OK	Modem manufactor identifier
ATI6	BSMW310_BF533_bfbsmw310_5457OK OK	Revision identification for modem modulation code
ATI8	000 000 000 000 OK	Switch settings Each DIP switch displayed as a decimal value. S1 S2 S3 S4 Notice switch setting is only reed at power-up and ATZ
ATI9	4101-0201 OK	Westermo SW release
	ERROR	Otherwise

S register: None

+ICF – Fixed DTE format

Supported by: TDW-33 TD-36 TD-36 485 TR-36

Description:

This commands specifies the data format between the modem and the DTE. Notice that format can't be set with rate set to auto.

Syntax

AT+ICF = <format>

AT+ICF = ?

AT+ICF?

Parameters:

<format>

0 Auto

4,4 7N2

5,1 7E1

5,0 7O1

3,4 8N1

2,1 8E1

2,0 8O1

4,1 7E2

4,2 7O2

1,4 8N2

1,1 8E2

1,2 8O2

Command example	Possible responses	Note
AT+ICF?	+ICF: (3,4) OK	Current format is 8N1
AT+ICF = ?	+ICF(0-5),(0-4) OK	Allowed values
AT+ICF = (3,4)	OK	
AT+ICF = <n>	ERROR	If n is not valid

S register: None

+IPR – Fixed DTE rate

Supported by: TDW-33 TD-36 TD-36 485 TR-36

Description:

This command specifies the data rate between the modem and the DTE.

Syntax

AT+IPR = <rate>

AT+IPR = ?

AT+IPR?

Parameters:

<rate>: baud rates that can be used by the DCE

0 (enables autobauding)

300

600

1200

2400

4800

9600

19200

38400

57600

115200

Command example	Possible responses	Note
AT+IPR?	+IPR: 9600 OK	Current rate is 9600 bit/s
AT+IPR = ?	+IPR: (0, 300, 600, 1200, 2400, 4800, 9600, 19200, 38400, 57600, 115200), OK	
AT+IPR = 38400	OK	Disable autobauding and set rate to 38400 bit/s
AT+IPR = 0	OK	Enable autobauding
AT+IPR = n	ERROR	If n is not valid

S register: None

\Kn – Break Control

Supported by: TDW-33 TD-36 TD-36 485 TR-36

Description:

This command controls the response of the modem to a break signal received from the terminal equipment, from the remote modem or through the \B command. The modem can respond in three different ways depending on the state of the modem. The value is written to S40 bit 3,4 and 5.

Syntax:

AT\K<n>

Parameters:

<n>

Mode 1

Modem is in on line data mode and a break is received from the DTE.

<n>

- 0: Enter on-line command modem, no break sent to the remote modem.
- 1: Clear data buffers and send break to remote modem.
- 2: Same as 0.
- 3: Send break to remote modem immediately.
- 4: Same as 0.
- 5: Send break to remote modem in sequence with transmitted data (Default).

Mode 2

Modem is in on line command mode and a \B is received in order send as a break to the remote modem.

<n>

- 0: Clear data buffers, send break to the remote modem.
- 1: Same as 0.
- 2: Send break to remote modem immediately.
- 3: Same as 2.
- 4: Send break to remote modem in sequence with transmitted data.
- 5: Same as 4.

Mode 3

A break is received from a remote modem during a non-error corrected connection.
<n>

- 0: Clear data buffers, send break to the DTE.
- 1: Same as 0.
- 2: Send break immediately to DTE.
- 3: Same as 2.
- 4: Send break to remote modem in sequence with transmitted data.
- 5: Same as 4. (Default)

Command example	Possible responses	Note
AT\K<n>	OK	The command is valid and accepted
	ERROR	Otherwise

S register: The value is written to S40 bits 3, 4 and 5.

&Kn – DTE-DCE flow control

Supported by: TDW-33 TD-36 TD-36 485 TR-36

Description:

This command controls the operation of local flow control between the DTE and DCE.

Syntax:

AT&K<n>

Parameters:

<n>

- 0: Disables Flow Control (Default)
- 3: Enables RTS/CTS
- 4: Enables XON/XOFF

Command example	Possible responses	Note
AT&K<n>	OK	<n>= 0 to 4
	ERROR	Otherwise

S register: The value is written to S39 bits 0, 1 and 2.

Ln – Speaker Volume

Supported by: TDW-33 TD-36 TD-36 485 TR-36

Description:

Sets the speaker volume control.

Syntax:

ATL<n>

Parameters:

L0: Low Volume

L1: Low Volume

L2: Medium Volume

L3: High Volume (Default)

Command example	Possible responses	Note
ATL<n>	OK	
	ERROR	Otherwise

S register: The value is written to S22 bits 0 and 1.

%L – Report Line Signal Level

Supported by: TDW-33 TD-36 TD-36 485 TR-36

Description:

This command returns a value which indicates the received signal level.

Syntax:

AT%L

Parameters:

None

Command example	Possible responses	Note
AT&L	009	
	OK	-9 dBm signal level
	ERROR	Otherwise

S register: None

*L – Display Stored Passwords and Callback numbers

Supported by: TDW-33 TD-36 TD-36 485 TR-36

Description:

This command displays stored Password and Callback numbers.

Syntax:

AT*L

Parameters:

None

Command example	Possible responses	Note
AT*L	0 – Password, Callback number 1 – Password, Callback number OK	
	ERROR	Otherwise

S register: None

Mn – Speaker Control

Supported by: TDW-33 TD-36 TD-36 485 TR-36

Description:

Speaker Control command.

Syntax:

ATM<n>

Parameters:

<n>

- 0: Speaker off
- 1: Speaker is on during call establishment, but off when receiving a carrier. (Default)
- 2: Speaker is always on
- 3: Same as 1 but only when answering, and not during call establishment.

Command example	Possible responses	Note
ATM<n>	OK	
	ERROR	Otherwise

S register: The value is written to S22 bits 2 and 3.

+MS – Select Modulation

Supported by: **TDW-33** **TD-36** **TD-36 485** **TR-36**

Description:

This command selects the modulation, enables or disables automode, specifies the receive rates and specifies the transmit rates using six subparameters.

Syntax:

+MS = <carrier>,<automode>,<min_tx_rate>,<max_tx_rate>,<min_rx_rate>,<max_rx_rate>

+MS = ?

+MS ?

Parameters:

<carrier>

V21 300 bit/s
V22 1200 bit/s
V22B 1200 or 2400 bit/s
V23C 75/1200, 1200/75 bit/s PSTN-mode dialled connections
V23HDX 1200/1200 half duplex PSTN dialled connections
(TD-36 and TD-36 485 also 2 wire leased line)
V23FDX 1200/1200 bit/s full duplex 4 wire leased line (only TD-36 485)
V32 4800 or 9600 bit/s
V32B 4800, 7200, 9600, 12000 or 14400 bit/s
V34 2400, 4800, 7200, 9600, 12000, 14400, 16800, 19200, 21600, 24000, 26400,
28800, 31200, 33600 bit/s
V34FC 2400, 4800, 7200, 9600, 12000, 14400, 16800, 19200, 21600, 24000, 26400,
28800, 31200, 33600 bit/s
V90A up to tx = 33600, rx = 56000 bit/s (client mode) Only TDW-33
V90D up to tx = 56000, rx = 33600 bit/s (server mode) Only TDW-33
B103 300 bit/s
B212 1200 bit/s

<automode>

0: Disable

1: Enable

<min_xx_rate>, <max_xx_rate>

Minimum and maximum data rate depending on modulation used.

Command example	Possible responses	Note
AT+MS = ?		The modem sends a string of information to the DTE consisting of supported options
AT+MS?		List current configuration

S register: None

\Nn – Select Operating mode

Supported by: TDW-33 TD-36 TD-36 485 TR-36

Description:

This command controls the preferred error correcting mode for a data connection

Syntax:

AT\N<n>

Parameters:

<n>

- 0: Selects normal speed buffered mode (disables error-correction mode).
- 1: Selects direct mode and is equivalent to &M0, &Q0 mode of operation. In this mode the serial port is directly connected to the data pump, which results in the lowest possible delay time. This is useful in i.e. the case of polled PLC systems where the response time is critical.
- 2: Selects reliable (error-correction) mode. The modem will first attempt a LAPM connection and then an MNP connection. Failure to make a reliable connection results in the modem hanging up.
- 3: Selects auto reliable mode. This operates the same as \N2 except failure to make a reliable connection results in the modem falling back to the speed buffered normal mode, \n0.
- 4: Selects LAPM error-correction mode. Failure to make an LAPM error-correction connection results in the modem hanging up. Note: The -K1 command overrides the \n4 command.
- 5: Selects MNP error-correction mode. Failure to make an MNP error-correction connection results in the modem hanging up.

Command example	Possible responses	Note
AT\N<n>	OK	
	ERROR	Otherwise

S register: The value is written to S36 and S48 (see description).

On – Back to online mode

Supported by: TDW-33 TD-36 TD-36 485 TR-36

Description:

If a connection has been established and the modem is in online command mode, this command allows you to return to online data mode either with or without a retrain.

Syntax:

ATO<n>

Parameters:

<n>

0: Enters on-line mode without a retrain (Default).

1: Enters on-line mode with a retrain.

Command example	Possible responses	Note
ATO0	OK	Enters on-line mode without a retrain.
ATO1	OK	Enters on-line mode with a retrain
	ERROR	Otherwise or if not connected

S register: None

*Pn – Store Password and Callback numbers

Supported by: TDW-33 TD-36 TD-36 485 TR-36

Description:

Used for storing password and callback number 0 and 1 for the secure callback function. For compability reasons only. See also AT*WCBTAB

Syntax:

*P<n>:Password:Callbacknumber

Parameters:

<n>

0: Information for password 0 and callback number 0

1: Information for password 1 and callback number 1

Secure callback entry password must be none or 6-12 characters. secure callback entry number can be 0-20 characters.

Command example	Possible responses	Note
*P0:password:callbacknumber	OK	
	ERROR	Otherwise

S register: None

Qn – Result Code Control

Supported by: TDW-33 TD-36 TD-36 485 TR-36

Description:

The Q command controls the issuing of result codes sent to acknowledge AT commands and call status events (e.g. OK, ERROR, RING).

Syntax:

ATQ<n>

Parameters:

<n>

0: DCE transmits result codes (default)

1: Result codes are suppressed and not transmitted

Command example	Possible responses	Note
ATQ0	OK	DCE transmits result codes
ATQ1	OK	Result codes are suppressed and not transmitted

S register: The value is written to S14 bit 2.

%Q – Report Line Signal Quality

Supported by: TDW-33 TD-36 TD-36 485 TR-36

Description:

Command always respond with OK in on line command mode, ERROR will be sent on all other cases.

For compability reasons only. See also AT&V1

Syntax:

AT%Q

Parameters:

None

Command example	Possible responses	Note
AT%Q	OK	
	ERROR	Otherwise

S register: None

&Qn – Asynchronous Mode

Supported by: TDW-33 TD-36 TD-36 485 TR-36

Description:

This command is used to control connection modes permitted. It is used in conjunction with S36 and S48.

See also AT\Nn.

Syntax:

AT&Q<n>

Parameters:

<n>

- 0: Selects direct asynchronous operation. The value 000b is written to S27 bits 3, 1, and 0, respectively.
- 5: The modem will try to negotiate an error-corrected link. The modem can be configured using S36 to determine whether a failure will result in the modem returning on hook or will result in fallback to an asynchronous connection. The value 101b is written to S27 bits 3, 1 and 0 respectively (Default).
- 6: Selects asynchronous operation in normal mode (speed buffering). The value 110b is written to S27 bits 3, 1 and 0, respectively.

Command example	Possible responses	Note
AT&Q<n>	OK	
	ERROR	If not valid

S register: The value is written to S27 (see description).

S – S-Register

Supported by: TDW-33 TD-36 TD-36 485 TR-36

Description:

Sets and reads S registers.

Syntax:

ATS<value>[< = num>|<?>]

Parameters:

<value> Register

< = num> Set value number, 0-255

<?> Return register

Command example	Possible responses	Note
ATS0=2	OK	Number value 0-255
ATS0?	2 / OK	Number value 0-255
	ERROR	Register not valid or number out of range

S register: None

&Sn – Set DSR signal

Supported by: TDW-33 TD-36 TD-36 485 TR-36

Description:

This commands controls the Data Set Ready (DSR) signal.

Syntax:

AT&S<n>

Parameters:

<n>

0: DSR always on

1: DSR off in command mode, DSR on in data mode

Command example	Possible responses	Note
AT&S0	OK	DSR always on
AT&S1	OK	DSR off in command mode, DSR on in data mode

S register: The value is written to S21 bit 6.

Vn – Result format

Supported by: TDW-33 TD-36 TD-36 485 TR-36

Description:

This command selects the sending of short-form or long-form codes to the DTE.

Syntax:

ATV<n>

Parameters:

<n>

0 (Information responses): <text><CR><LF>

0 (Result codes): <numeric code><CR>

1 (Information responses): <CR><LF><text><CR><LF>

1 (Result codes): <CR><LF><verbose code><CR><LF>

Command example	Possible responses	Note
ATV0	0	DCE transmits limited headers and trailers and numeric result codes
ATV1	OK	DCE transmits full headers and trailers and verbose response text

S register: The value is written to S14 bit 3.

\Vn – Single Line Connect Message

Supported by: TDW-33 TD-36 TD-36 485 TR-36

Description

This command enables or disables the single line connect message.

This command override the ATWn command.

See also ATWn

Syntax:

AT\V<n>

Parameters:

<n>

- 0: Connect messages are controlled by the settings X, Y, and S95. (Default)
- 1: Connect messages are displayed in the single line format described below subject to the command settings V (verbose) and Q (Quiet). In a non-verbose mode (V0), single line connect messages are disabled and a single numeric result code is generated for CONNECT DTE . The single line connect message format is:

Command example	Possible responses	Note
AT\V0	OK	
AT\V1	OK	

S register: None

&Vn – Display Information

Supported by: TDW-33 TD-36 TD-36 485 TR-36

Description

Displays information either of Current Configuration or last Connection Statistics

Syntax:

AT&V<n>

Parameters:

<n>

- 0: Display Current Configuration and Stored Profiles
- 1: Display present Connection Statistics
- 2: Display extended Connection Statistics

Command

example Possible responses

AT&V0

ACTIVE PROFILE:
E1 M0 Q0 V1 W0 X4 &A1 &B0 &C1 &D0 &K0 &Q5 &S1 \N4 %F3
S00:001 S02:043 S03:013 S04:010 S05:008 S06:003 S07:075 S08:001 S09:000 S10:004
S11:000 S12:000 S22:112 S25:005 S30:000 S31:000 S40:040 S41:003 S46:002 S91:010
S95:000

STORED PROFILE 0:
E1 M0 Q0 V1 W0 X4 &A1 &B0 &C1 &D0 &K0 &Q5 &S1 \N4 %F3
S00:001 S02:043 S03:013 S04:010 S05:008 S06:003 S07:075 S08:001 S09:000 S10:004
S11:000 S12:000 S22:112 S25:005 S30:000 S31:000 S40:040 S41:003 S46:002 S91:010
S95:000

STORED PROFILE 1:
E1 M1 Q0 V1 W0 X4 &A1 &B0 &C1 &D2 &K0 &Q5 &S1 \N4 %F3
S00:001 S02:043 S03:013 S04:010 S05:008 S06:003 S07:075 S08:001 S09:000 S10:004
S11:000 S12:000 S22:116 S25:005 S30:000 S31:000 S40:040 S41:003 S46:002 S91:010
S95:000

TELEPHONE NUMBERS:
0 = 1 =
2 = 3 =

OK

Command example	Possible responses	
AT&V1	Norm	IDLE
	Compression	NONE
	Protocol	NONE
	Speed Rx/Tx	0/0
	Octets Sent/Rec	0/0
	DataFrames Sent/Rec	0/0
	ErrorFrames	0
	ResentFrames	0
	Frames Sent/Rec	0/0
	CompressionEfficiency	100
	ProtocolProgress	0
	Disconnect Reason	No disconnection
	SNR	0 dB
	RXLevel	0 dB
	Echo Level	0 dB
	Near Echo Level	0 dB
	Far Echo Level	0 dB
	Frequency Offset	+0.0 Hz
	Timing Offset	0
	Line Voltage	0V
	Roundtrip Delay	0 ms

OK

S register: None

+VRN – Ringback Never Appeared Timer

Supported by:	TDW-33	TD-36	TD-36 485	TR-36
---------------	--------	-------	-----------	-------

Description:

This command sets the length of the time the modem will wait between ringbacks during call originating before the modem can assume that the remote station has gone off hook.

Syntax

+VRN=<n>

+VRN?

+VRN=?

Parameters

<n>

Decimal number 0 specifying the time period that the modem will wait for Ringback during call origination.

A value of 0 forces the modem to report the OK result code. All other values give ERROR as a result code.

S register: None

+VTS – Send Voice Tone(s)

Supported by:	TDW-33	TD-36	TD-36 485	TR-36
---------------	--------	-------	-----------	-------

Description:

This command causes the modem to send DTMF digits.

Syntax

+VTS=[<freq1>,<freq2>,<dur>]

+VTS=?

Parameters

freq1 (200-3000)

freq2 (200-3000)

dur (0-255)

S register: None

Wn – Connect message control

Supported by: TDW-33 TD-36 TD-36 485 TR-36

Description:

This command controls the format of CONNECT message.
This command can be overide by ATS95 and ATIV commands.

Syntax:

ATW<n>

Parameters:

<n>

- 0: Upon connection, the modem reports only the DTE speed.
- 1: Upon connection, the modem reports the line speed, the error correction protocol, and the DTE speed respectively.
- 2: Upon connection, the modem reports the DCE speed

Command example	Possible responses	Note
ATW	OK	<n> = 0,1,2
	ERROR	Otherwise

S register: The value is written to S31 bits 2 and 3.

&Wn – Store system setting

Supported by: TDW-33 TD-36 TD-36 485 TR-36

Description:

This command saves the current (active) configuration (profile), including S-Registers, in one of the two user profiles as denoted by the parameter value.

Syntax:

AT&W<n>

Parameters:

<n>

- 0: Store the current configuration as profile 0
- 1: Store the current configuration as profile 1

Command example	Possible responses	Note
AT&W<n>	OK	Writes configuration <n> to EEPROM

S register: None

*WACCTAB – Accepted numbers for A-number answering

Supported by: TDW-33 TD-36 TD-36 485 TR-36

Description

The table can hold the numbers accepted for A-number answering. Up to 10 numbers can be defined, all numbers defined will be compared to the incoming Caller ID when A-number answer is enabled.

Syntax:

AT*WACCTAB = <entry>,<"num">

AT*WACCTAB=?

AT*WACCTAB?

Parameters:

<entry>

Secure callback entry [1-10]

<"num">

Accepted Caller ID [0-20 characters].

Command example	Possible responses	Note
AT*WACCTAB = 1,"12345"	OK	Set number (12345) in entry 1
AT*WACCTAB = 2,"678"	OK	Set number (678) in entry 2.
AT*WACCTAB = 2,""	OK	Delete entry 2
AT*WACCTAB?	OK	List parameters
AT*WACCTAB = ?	*WACCTAB : (0-10), ("0-20 CHAR") OK	List command parameters
	ERROR	Otherwise

S register: None

*WCID – Caller ID / A-Number

Supported by: TDW-33 TD-36 TD-36 485 TR-36

Description

This command set and display Caller ID parameters and data.

The modem supports different standards of CID (Caller Identification) which is set with the mode parameter. Which standard used varies between countries and operators, please check with your operator for correct mode.

The format parameter sets the way of presenting the CID/A-number. When A-number detection is enabled there will be no presentation, but the modem will compare the CID to the numbers stored in the WACCTAB. On a true compare the modem will answer the call immediately. If the CID not compares to a number in the WACCTAB the normal answering procedure controlled by S0 and ATA takes place.

Syntax:

AT*WCID = <format>,<mode>

AT*WCID = ?

AT*WCID?

Parameters:

<format>

- 0 Disables Caller ID /A-Number
- 1 Formated CID
- 2 Unformated CID
- 3 A-Number detection

<mode>

- 0 Between first and second ring
- 1 After detecting CAS
- 2 After line reversal
- 3 DTMF CID

Command example	Possible responses	Note
AT*WCID = 1,3	OK	Selects DTMF Caller ID with formated string presentation.
AT*WCID = 3,3	OK	Selects A-Number detection based on DTMF CID
AT*WCID?	*WCID: 1,3 OK	Display current *WCID settings
AT*WCID = ?	*WCID: (0-3), (0-3) OK	Display command parameters

S register: None

*WCB – Secure access and Callback

Supported by: TDW-33 TD-36 TD-36 485 TR-36

Description

The secure callback functionality makes the established link more secure. After an incoming call the modem will make a callback to either a preconfigured number or to the incoming number. The callback can be protected by a password. The unit can also be configured for a secure access without callback.

If the password is enabled, the calling part will be prompted for the password directly after connection. When the password is entered correctly, the modem will disconnect the current link and make a callback after a preset number of seconds WCBTIME.

If the unit is configured with password security, it will allow data only after the password is correctly entered. After 3 retries of entering wrong password or after 60 seconds, the link will be disconnected and the callback/secure access aborted.

Numbers and password used by the function is stored in the ***wcbtab** table
See also AT*WCBTAB.

Syntax:

AT*WCB = <n>

AT*WCB=?

AT*WCB?

Parameters:

<n>

- 0: Callback disabled (default)
- 1: Callback enabled, No password needed, callback number only in position 1 in *wcbtab (wcbtab1)
If “*wcbtab1” is empty no callback will be initiated.
- 2: Callback enabled, No password needed, callback to incoming number
No “RING” message will be sent to the local serial port at that time.
If the Caller ID is present the modem will callback to this number after the time of WCBTIME.
When the connection is established CONNECT message will be sent to the DTE interface.
Note that WCID must be enabled and set to the correct format for this function to operate properly.

- 3: Access security enabled, Password in one or more positions in WCBTAB<n> (x = 1 -10). If a correct password is detected the connection is opened without any callback.
 The call request will be accepted silently. No “RING”and “CONNECT” message will be sent to the local DTE interface at that time.
 After a successful connection the answering modem will send the message: “PASSWORD:“ to the originating side. Enter password and press return.
 There will be three attempts given to enter the password correctly.
 There is a fixed timeout of 60s to enter the password.
 If the entered password is correct the modem will send message “RING” and “CONNECT” to the DTE interface.
- 4: Callback enabled, Password and callback number in WCBTAB.The call request will be accepted silently, no “RING”and “CONNECT” message will be sent to the DTE interface at that time.
 After a successful connection the answering modem will send the message: “PASSWORD:“ to the originating modem.
 When the connection is established the modem will send message “CONNECT” to the DTE interface.
- 5: Callback enabled, Password in WCBTAB, callback to incoming number. Except password is needed the same as n = 2
- 6: Callback enabled, Password in one or more positions in *wcbtab (x = 1,2 .. 10), call-back to number that is entered after password check is OK.

Command example	Possible responses	Note
AT*WCB = 0	OK	Disable Callback function
AT*WCB = 1	OK	Enable Callback function
AT*WCB=?	*WCB: (0,6)	Display command parameters
AT*WCB?	*WCB:0	Display current settings
	ERROR	Otherwise

S register: None

*WCBTAB – Secure access table

Supported by: TDW-33 TD-36 TD-36 485 TR-36

Description

The command handle numbers and password for secure callback, secure access, secure connections etc. The command is used for the following services:

Secure Callback

Secure Access

The Secure Access Table consist of a table of 10 Secure Access Entries. Where a Secure Access Entry consist of outgoing number field (size is up to 20 characters long), a password field (if used, size should be between 6 and 12 characters long, otherwise 0 size)

Syntax:

AT*WCBTAB = <entry>,<"num">,<"psword">

AT*WCBTAB=?

AT*WCBTAB?

Parameters:

<entry>

Secure callback entry [1-10].

<"num">

Secure callback entry number [0-20 characters].

<"psword">

Secure callback entry password [0, 6-12 characters].

Command example	Possible responses	Note
AT*WCBTAB = 1, "12345","QWERTY"	OK	Set number (12345) and password ("QWERTY") in entry 1
AT*WCBTAB=2,"678",""	OK	Set number (678) in entry 2.
AT*WCBTAB?	OK	List parameters
AT*WCBTAB = ?	*WCBTAB : (0-3), ("0-20 CHAR"), ("0,6-12 CHAR") OK	List command parameters
AT*WCBTAB=1,"", ""	OK	Delete entry
	ERROR	Otherwise

S register: None

*WCBTIME – Callback delay time

Supported by: TDW-33 TD-36 TD-36 485 TR-36

Description

The command sets the number of seconds delay between hang up and callback dialing start.

Syntax:

AT*WCBTIME = <n>

Parameters:

<n>

Callback delay [0-255] s

Command example	Possible responses	Note
AT*WCBTIME = 10	OK	Set callback delay to 10s
AT*WCBTIME?	OK	List parameters
AT*WCBTIME = ?	*WCBTAB : (0-255) OK	List command parameters
	ERROR	Otherwise

S register: None

*WDB – Dial Backup

Supported by: TD-36 485

Description

This command set and display the dial backup parameters and data. When the dial backup function is configured and enabled, the 2-wired leased line will have a PSTN backup line. If the leased line connection is lost, the modem will try (number of retries) to reconnect before it will try to connect (to the number specified) on the PSTN line. If the reconnect time is set and the backup line is used, the modem will close the PSTN connection after the specified number of minutes and then try to connect on the 2-wired leased line

Syntax:

AT*WDB = <"num">,<retries>,<time>

AT*WDB = ?

AT*WDB?

Parameters:

<"num">

Dial backup number string (0-16 characters)

<retries>

Number of connect fails (0-9, 3 Default)

<time>

Time before reconnect (0-255, 0 Default = OFF)

Command example	Possible responses	Note
AT*WDB = "12345",3,1	OK	Dial 12345 on the PSTN line after 3 failed connection retries on the 2 leased line connection. Disconnect the PSTN line and try to make a new connection on the leased line connection after 1 minute.
AT*WDB?	*WDB: 12345, 3, 1 OK	List parameters
AT*WDB = ?	*WDB: ("0-16 CHAR"), (0-9), (0-255) OK	List command parameters
	ERROR	Otherwise

S register: None

*WI – Information string

Supported by: TDW-33 TD-36 TD-36 485 TR-36

Description

The command enable or disable the sending of an information string to the DTE or remote DCE according to the parameter supplied. The parameter values, if valid, are stored in the active profile.

Syntax:

AT*WI=<"string">,<mode>

Parameters:

<"string">

Information string [0-40 characters].

<mode>

Information string mode [0-4].

- 0: Disable the function
- 1: Send information string to remote DCE when inactivity timer (S30) expires.
- 2: Send information string to remote DCE after connect message or DCD.
- 3: Send information string to DTE when inactivity timer (S30) expires.
- 4: Send information string to DTE after connect message or DCD.

Other values: "ERROR" string is sent back.

Command example	Possible responses	Note
AT*WI="Info string 1",1	OK	Send info string to remote DCE when inactivity timer expires.
AT*WI="Info string",4	OK	Send info string to DTE when connected.
AT*WI=""	OK	Delete info string and disable function (mode to 0)
AT*WI=,0	OK	Disable function
AT*WI=,1	OK	Enable function with mode set to 1
AT*WI?	*WI: string, mode OK	List parameters
AT*WI=?	*WI : (0-40 CHAR), (0-255) OK	List command parameters
	ERROR	Otherwise

S register: See S30

*WIE – Ignore Errors

Supported by: TDW-33 TD-36 TD-36 485 TR-36

Description

With this command all error responses can be disabled and commands is giving an OK response, format according to ATV setting. The intention with this command is to enable use of application which has been written for other types of modems and has been using undocumented / bugs in command interpretation in the replaced modem.

Syntax:

AT*WIE=<n>

AT*WIE=?

AT*WIE?

Parameters:

<n>

0: Report Errors. (Default).

1: Disable Error reporting.

Command example	Possible responses	Note
AT*WIE=<n>	OK	The command is valid and accepted
	ERROR	Otherwise (depends on setting of command)

*WIOL – Generic I/O list

Supported by: **TD-36 485**

Description:

This command is used to program the list of I/O entries with parameters and data.

Syntax:

AT*WIOL = <entry>,<service>,<flag>,<timeout>,<priority>,<"data1">,<"data2">,<data3>,<data4>,<data5>,<data6>

AT*WIOL = ? List all table entries. Listing will present a short form table of the entire I/O list..

AT*WIOL=n? List all data parameters for a defined entry.

AT*WIOL?

Parameters:

<entry>

I/O entry number, up to 10 entries can be defined.

<service>

I/O entry service

0 = NONE	No service defined for this entry
1 = DIAL	Makes a connection to the number defined in <data1>
2 = SMS	<data1> Destination number of the SMS <data2> SMS-message. <data3> SMS service provider number <data4> SMS protocol type (0 = NONE,1 = UCP,2 = TAP) <data5> Password if required by provider.
3 = TEXT	Make a connection to number defined in <data1> and transfer text defined in <data2>.
4 = EMAIL	Reserved for future use, service not implemented
5 = OUT	Make a connection to the number defined in <data1> and set/pulse the remote output according to pattern defined in string defined in <data2>. The connection is terminated after the pattern is transferred.
6 = CMD	AT command specified by <data1> is executed when the entry is triggered
7 = TRANS	Makes a connection to number defined by <data1>, I/O is transferred transparently between the two units. The transparent mode must be ended by a timeout.

<flag>

Defines if the establishment of service shall be retried, the time between retries is controlled by register S7.

0 = NO	No retry, tries once to perform requested action
1 = RETRY	Retry infinitely to establish service according to current table entry.
2 = RETRY_3	Do 1 try and max 3 retries.
3 = NEXT_OK	If current service ends with OK the service specified by next table entry will be triggered. If fail to perform/establish the current entry service the unit will return to idle.
4 = NEXT_ERR	The unit will execute service specified by next table entry if fail to perform/establish current service. If service according to current table entry terminates normally the unit will return to idle and wait for any new event trigger.
5 = NEXT_ALLWAYS	The next table entry will always be execute regardless of the exit status of the current.

<timeout>

Timeout is used in Dial and Transparent I/O. The timeout is designed as a inactivity timer and will be retrigged for each Data / I/O transfer. The timeout is the only normal way to terminate Dial and Transparent I/O.

Please see **Table 1** for reference of state after termination by timeout.

Setting a timeout for any other service than transparent I/O will not cause any failure but will not have any function.

<timeout>**Function of <timeout>**

= 0	The service will not be terminated
= 1 – 255	The timeout is specified in units of 10 s. Valid values 1 – 255 *10 s (10 s – 2550 s)

<priority>

Priority of the service specified.

<priority>**Function of <priority>**

= 0	An existing connection will not be terminated. Retries will be made according to setting of <flag>, time between retries is set by register S7.
= 1	The current connection will be terminated before the connection specified by service is established.

<"data1">

The interpretation of this field depends on the service specified for the entry.
The field accepts 0 – 20 characters.

Service	Function of <"data1">
DIAL	Number to connect to
SMS	Phone number of SMS receiver
TEXT	Phone number of TEXT receiver; if left empty the TEXT is sent out on the local DTE connection.
EMAIL	Reserved.
OUT	Phone number of the modem where the output shall be set. If <data1>, is empty the transfer will be to the local digital output.
CMD	AT command string to be executed when the entry is triggered, can be used to modify the trigger condition
TRANS	Phone number of the modem to which the transparent I/O should occur. For dependencies of other parameters and line type, Please See Table 1
	<data1> Makes a connection to the number defined and start
	= number Transparent I/O transfer between the two units.
	<data1> = empty Transparent I/O transfer will use an existing data connection.

<"data2">

Interpretation of field <"data2"> is also service dependent the size is 0 – 160 characters.

Service	Parameter <"data2">
DIAL	Not used
SMS	The SMS message
TEXT	Text message
EMAIL	E-mail message
OUT	A sequence of "101.." to be transferred to the addressed output. Each state will be t_a long.
CMD	Not used
TRANS	Not used

<"data3">

Field <"data3"> is only used for SMS and EMAIL service.

Service	Parameter <"data3">
SMS	SMS provider number.
EMAIL	Reserved for ISP number

<data4>

Field <data4> is only used for SMS and EMAIL service.

Service	Parameter <data4>
SMS	SMS protocol 0 = No protocol, 1 = UDP, 2 = TAP
EMAIL	Reserved for mail protocol

<"data5">

Field <"data5"> is only used for SMS and EMAIL service.

Service	Parameter <"data5">
SMS	Password for access to SMS provider
EMAIL	Reserved for password to mail server

<"data6">

Field <"data6"> is only used for EMAIL service.

Service	Parameter <"data6">
EMAIL	Reserved for username to mail server

Table 1 Dial and Transparent I/O connection types

Connected	Data 1	prio	Line Type	
No	Empty	No	LL	Illegal
No	Empty	Yes	LL	Illegal
No	Number	No	LL	Illegal
No	Number	Yes	LL	Illegal
Yes	Empty	No	LL	Normal Transparent I/O over leased line*
Yes	Empty	Yes	LL	Normal Transparent I/O over leased line*
Yes	Number	No	LL	Normal Transparent I/O over leased line, number discard*
Yes	Number	Yes	LL	Normal Transparent I/O over leased line, number discard*
No	Empty	No	CS	Error, try to establish service failed
No	Empty	Yes	CS	Error
No	Number	No	CS	Normal Transparent I/O over Circuit switched line
No	Number	Yes	CS	Normal Transparent I/O over Circuit switched line
Yes	Empty	No	CS	Use current connection for I/O transfer. The Empty data 1 will override priority*
Yes	Empty	Yes	CS	Use current connection for I/O transfer*
Yes	Number	No	CS	Due to that line is busy and no priority set the modem will retry connection according to <flag>
Yes	Number	Yes	CS	Disconnect and dial Number

LL = Leased Line PSTN or ISDN

CS = Circuit Switched PSTN, ISDN or GSM

* The existing data connection will be paused during transparent I/O transfer.

The modem will use the flow control specified by flow control command.

If no flow control set DTE data will be discarded during the Transparent I/O transfer.

When the transparent I/O transfer is terminated by timeout the connection will revert to data-mode and activate CTS / sending XON.

Example 1:

Define entry #1 for SMS service with 3 retries, priority, receiver of SMS 016480251, message "Hello Westermo", provider 00491712521002, TAP protocol, password PG1
AT*WIOL =1,2,2,0,1,"0164251","Hello Westermo","00491712521002",2,"PG1",
OK

Example 2:

Define entry #4 for Transparent I/O service with retry for ever, priority, timeout 400s, remote modem number 016480250
AT*WIOL =4,7,1,40,1,"016480250",,,0,,
OK

Example 3:

List the entry table:

AT*WIOL?

Generic I/O Table

NR	SERV	FLAG	TIME	PRIO	DATA1	DATA2	DATA3	DATA4	DATA5	DATA6
1	2	2	0	1	0164251	Hello..	00491..	2	PG1	
2	0	0	0	0				0		
3	0	0	0	0				0		
4	7	1	40	1	01648..			0		
5	0	0	0	0				0		
6	0	0	0	0				0		
7	0	0	0	0				0		
8	0	0	0	0				0		
9	0	0	0	0				0		
10	0	0	0	0				0		

AT*WIOl=4?
Generic IO Entry 4
4_Service=7
4_Flag=1
4_Timeout=40
4_Priority=1
4_Data1=016480250
4_Data2=
4_Data3=
4_Data4=0
4_Data5=
4_Data6=
OK

Example 4:

Read the format string:

AT*WIOl = ?

*WIOl: (1-10), (0-7), (0-3), (0-255), (0-1), (“0-20 char”), (“0-160 char”), (“0-20 char”),
(0-2), (“0-8 char”), (“0-20 char”)

OK

S register: None

*WIOD – Generic I/O delete entry

Supported by: **TD-36 485**

Description:

This command delete one or more entries in the Generic I/O list.

Syntax:

AT*WIOD = <n>[,<m>]

AT*WIOD = ?

Parameters:

<n>

Entry number to be deleted (n = 1..10)

[,<m>]

Range of entries to be deleted, from entry <n> to entry <m> (<m> included).

Command example	Possible responses	Note
AT*WIOD = 2	OK	Delete Generic IO list entry 2
AT*WIOD = 3,7	OK	Delete Generic IO list entries 3, 4, 5, 6 and 7
AT*WIOD = ?	*WIOD: (1-10)[,(1-10)] OK	Display command parameters

S register: None

*WIOP – Generic I/O parameters

Supported by: **TD-36 485**

Description:

This command set the I/O parameters.

Syntax:

AT*WIOP = <ta>,<Tp>,<type>,<trig>,<norm>

AT*WIOP = ?

AT*WIOP?

Parameters:

<ta>

Min trig pulse time in 10 ms increments [1-255].

This parameter sets the minimum time the pulse/level must be active.

A pulse shorter than this time will be skipped.

<Tp>

Pulse period time in 10 ms increments [1-255]

Sets the minimum time between pulses. The number of pulses will be calculated when the time between pulses is longer than Tp. Note Tp must be longer than 2ta.

<type>

Trig source and type

0 = NO	Trigger not used
1 = LEVEL	Trigger source is the digital input level.
2 = PULSE	Trigger source is an edge on the digital input.
3 = DCD	Trigger internally coupled to reflect the DCD signal
4 = DTR	Trigger internally coupled to reflect the DTR signal
31 = DCD PSTN	Trigger internally coupled to reflect the DCD signal on the PSTN interface
32 = DCD LL	Trigger internally coupled to reflect the DCD signal on the Leased Line interface

<trig>

Trigger level

0 = NO	Trigger not used
1 = HIGH	Defines that a high level triggers the service
2 = LOW	Defines that a low level triggers the service
3 = POS	A positive edge triggers the service
4 = NEG	A negative edge triggers the service
5 = FLANK	A positive or negative flank triggers the service
6 = FLANK 2	A positive flank triggers service 1, a negative flank triggers service 2

<norm>

Normal inactivated state of the output as well as the source controlling the output.

0 = NO	Output not used
1 = I/O operation	Operation controlled by remote I/O Transparent or Out
2	Reserved
3 = DCD	Output will be controlled by DCD. An active DCD will activate the output.
4 = DTR	Output will be controlled by DTR. An active DTR will activate the output
31 = DCD PSTN	Output is controlled by DCD on the PSTN interface
32 = DCD LL	Output is controlled by DCD on the Leased Line interface

Note! If LEVEL trigged input is programmed, all defined entries will be trigged.

Command example	Possible responses	Note
AT*WIOP = 50,100,1,1,3	OK	Command valid and accepted
AT*WIOP=50,100,2,1,3	OK	Change input type to be pulse trigged
AT*WIOP?	*WIOP :TA = 50,TP = 100, TYPE = 2,TRIG = 1, NORM = 3 OK	List parameters
AT*WIOP=?	*WIOP: (1-255), (1-255), (0-4, 31, 32), (0-6), (0-4, 31, 32) OK	List command parameters
	ERROR	Otherwise

S register: None

*WIOT – General I/O test

Supported by: **TD-36 485**

Description

This command executes the specified entry as if it was triggered by the normal trigger condition.

Syntax:

AT*WIOT=<entry_num>[,<IO_state>]

AT*WIOT=?

Parameters:

<entry_num>

I/O entry index number (0-10) 1-10 selects the entry at the corresponding index in the table. Selecting entry num=0 selects the local output, the state of the output is selected with parameter IO_state.

[,<IO_state>]

The state to set the local output (0 or 1) when entry_num is set to 0.

Command example	Possible responses	Note
AT*WIOT=2	OK	Trigger and execute entry 2 in the table
AT*WIOT=?	*WIOT: (0-10)[,(0-1)]OK Error	List command parameters otherwise

S register: None

*WRCP – Remote configuration password

Supported by: TDW-33 TD-36 TD-36 485 TR-36

Description

This command set remote configuration password. The remote configuration password decreases the risk of frauding when the remote access is enabled.

If password is left blank a <CR> as response to the “C PASSWORD:” prompt will give direct access to the remote online command mode. The remote configuration is reached through giving the remote access escape sequence consisting of four + signs “++++” in on line data mode. When the remote modem detects this escape sequence it will respond with the remote configuration password prompt. “C_PASSWORD:”.

Notice if remote configuration should be accessible when the Secure Callback is enabled a password must have been set for the remote configuration not to frauding the security.

Syntax:

AT*WRCP=<password>

AT*WRCP=?

AT*WRCP?

Parameters:

<password>

Remote configuration password, must be none or 6 to 12 characters long. Only standard characters are allowed (0-9, a-z)

Command example	Possible responses	Note
AT*WRCP=QWERTY	OK	Set remote access password
AT*WRCP?	*WRCP = QWERTY OK	Display current *WRCP password
AT*WRCP=?	*WRCP: (0, 6-12 CHAR) OK	Display command parameters

*WRCA – Remote configuration activate

Supported by: TDW-33 TD-36 TD-36 485 TR-36

Description

This command activate the remote configuration function.

Notice commands also controls the remote access via Generic I/O. The Generic I/O access is independent of the remote configuration password set with *WRCP command.

Syntax:

AT*WRCA=<n>

AT*WRCP=?

AT*WRCP?

Parameters:

<n>

0: Disables Remote Configuration

1: Enables Remote Configuration. (Default).

Command example	Possible responses	Note
AT*WRCA = <n>	OK	The command is valid and accepted
	ERROR	Otherwise

S register: None

*WRCE – Remote configuration end

Supported by: TDW-33 TD-36 TD-36 485 TR-36

Description

This command ends the remote configuration session.

Syntax:

AT*WRCE

Parameters:

None

Command example	Possible responses	Note
AT*WRCE		Ends a remote access session

Xn – Extended Result Codes

Supported by: TDW-33 TD-36 TD-36 485 TR-36

Description:

This command selects which subset of the result messages will be used by the modem to inform the DTE of the results of commands.

Syntax:

ATX<n>

Parameters:

<n>

- 0: Enables result codes 0 through 4, the modem ignores dial tone and BUSY signals, if allowed by the local PTT (blind dialling)
- 1: Enables all result codes except 6 and 7, the modem ignores dial tone and BUSY signals, if allowed by the local PTT (blind dialling).
- 2: Enables all result codes except 7, the modem ignores busy signals, if allowed by the local PTT.
- 3: Enables all result codes except 6, the modem ignores dial tone if allowed by the local PTT.
- 4: Enables all result codes (default).

Command example	Possible responses	Note
ATX<n>	OK	
	ERROR	Otherwise

S register: The value is written to S22 bits 4,5 and 6.

&Yn – Designate a Default Reset Profile

Supported by: TDW-33 TD-36 TD-36 485 TR-36

Description:

This command selects which user profile will be used after a hard reset.

Syntax:

AT&Y<n>

Parameters:

<n>

- 0: The modem will use profile 0
- 1: The modem will use profile 1

Command example	Possible responses	Note
AT&Y<n>	OK	
	ERROR	Otherwise

S register: None.

Zn – Soft Reset

Supported by: TDW-33 TD-36 TD-36 485 TR-36

Description:

This command do a soft reset and restores the configuration profile according to the parameter supplied.

If no parameter is specified, zero is assumed.

Syntax:

ATZ<n>

Parameters:

<n>

0: Soft reset, profile 0

1: Soft reset, profile 1

Command example	Possible responses	Note
ATZ<n>	OK	<n> = 0,1
	ERROR	Otherwise

S register: None.

&Zn = x – Store Telephone Number

Supported by: TDW-33 TD-36 TD-36 485

Description:

The modem can store up to four telephone numbers and each telephone number dial string can contain up to 31 digits. Entry 0 is used for DTR and TxHotline call, see AT&B<n>

Syntax:

AT&Z<n> = <string>

Parameters:

<n>

0: Telephone number 0

1: Telephone number 1

2: Telephone number 2

3: Telephone number 3

<string>

Dial string from 0 to 31 characters

Command example	Possible responses	Note
AT&Z<n> = <string>	OK	The number is stored
	ERROR	Otherwise

S register: None.

* S-registers

Register	Function	Range	Units	Saved	Default	Note
S0	Rings to Auto-Answer	0–255	Rings	*	2	Determines the number of rings before taking the line. Assigning a value from 1 to 255 places the modem in auto-answer mode. Setting S0 to 0 disables auto-answer mode.
S1	Ring Counter	0–255	Rings		0	S1 is incremented each time the modem detects a ring signal on the telephone line. It is cleared if no rings occur over any eight second interval.
S2	Escape Character ASCII	0–255	ASCII	*	43 (02Bh)	S2 holds the ASCII value of the escape code. The default value is 43 (ASCII "+"). S2 can be set to any value from 0 to 127. To return to the command state when the escape code is disabled, the distant modem must hang up (local modem loses carrier).
S3	Carriage Return Character	0–127	ASCII	*	13 (0Dh)	S3 holds the ASCII value of the carriage return character. Default a value of 13 is used. If the data terminal equipment is non standard, a different value can be used. This character serves as the command line terminator and the result code terminator. This character must not be set to a value greater than 127.
S4	Line Feed Character	0–127	ASCII	*	10 (0Ah)	S4 holds the ASCII value of the line feed character. The default value is 10. This character must not be set to a value greater than 127.

Register	Function	Range	Units	Saved	Default	Note
S5	Backspace Character	0–128	ASCII	*	8	S5 holds the ASCII value of the back space control character. The default value is 8. The backspace character must not be set to a value corresponding to a printable ASCII character (which is between 33 and 126).
S6	Dial Delay Blind dialing	0–255	s	*	3	This register programs the pause time before continuing the dial process. (in case there is no waiting for dialtone). Units is in seconds. Maximum = 255. Default = 3
S7	Wait Time for Carrier, Silence, or Dial Tone	0–255	s	*	50	This register gives the answer tone and silence timeout during dialing before hanging up. Units is in seconds. Maximum = 255. Default = 50. In leased line mode, this register is used as synchronisation timeout (answer tone – calling tone synchronisation) between the calling and answering modem. If the timeout is expired, the modem will restart it's training until the number of synchronization attempts is reached.

Register	Function	Range	Units	Saved	Default	Note
S8	Pause time for comma dial modifier	0–255	s	*	2	The function of the “comma” separator depends on the value assigned to register S8. The value represents the pause duration of the modem before dialing the digit following the comma in the dial command line. The pause time is expressed in units of 1 second and ranges from 0 to a maximum value of 255. In some countries the maximum value is limited. If, country code sets a maximum value and, 2 or more consecutive separators are used, only the first will be considered..
S10	Lost Carrier To Hang Up Delay	1–255	0.1 s	*	14	Register S10 determines the delay time between the loss of the carrier and when the modem disconnects. This delay allows the carrier to drop momentarily without causing a disconnect. The register is given in 100 ms units. Default = 14. If you assign the value to 255 the carrier disconnect function is disabled.
S11	DTMF Tone Duration	50-255	ms	*	95	Country dependent. Can not be modified.

Register	Function	Range	Units	Saved	Default	Note
S12	Escape Prompt Delay	0–255	20 ms	*	50	<p>S12 defines the maximum period, in fiftieths of a second, allowed between receipt of the last character of the three escape character sequence from the DTE and sending of the OK result code to the DTE. If any characters are detected during this time, the OK will not be sent.</p> <p>Note that sending of the OK result code does not affect entry into command mode.</p> <p>Range: 0–255 1/50 of a second</p> <p>Default: 50 (1 second)</p>
S13	Number of synchronisation attempts	0–255		*	0	<p>In leased line mode register S13 defines the number of synchronization attempts before going idle. Number of synchronisation attempts = 0 means endless loop.</p>

Register	Function	Range	Units	Saved	Default	Note
S14	General Bit Mapped Options	–	–	*	138	<p>Definition: S14</p> <p>Indicates the status of command options.</p> <p>Bit 0 This bit is ignored</p> <p>Bit 1 Command echo(En) 0 = Disabled 1 = Enabled (Default)</p> <p>Bit 2 Quiet Mode(Qn) 0 = SendResults(Default) 1 = Verbose</p> <p>Bit 3 Result Codes (Vn) 0 = Numeric 1 = Verbose (Default)</p> <p>Bit 4 Dial Abort(&An) 0 = Enable (Default) 1 = Disable</p> <p>Bit 5 Reserved</p> <p>Bit 6 Password(*Gn) 0 = Disabled (Default) 1 = Enabled</p> <p>Bit 7 Originate/Answer 0 = Answer 1 = Originate (Default)</p>
S21	V.24 General Bit Mapped Options Status		–	*	36 (24h)	<p>Definition: S21</p> <p>Indicates the status of command options.</p> <p>Bit 0 Reserved (0)</p> <p>Bit 1 Reserved (0)</p> <p>Bit 2 Reserved (0)</p> <p>Bit 3-4 DTR behaviour (&Dn) 0 = &D0 1 = &D1 2 = &D2 4 = &D3 (Default)</p> <p>Bit 5 DCD Option 0 = &C0 1 = &C1</p> <p>Bit 6 DSR Behaviour 0 = &S0 1 = &S1</p> <p>Bit 7 Reserved</p>

Register	Function	Range	Units	Saved	Default	Note
S22	Speaker/ Results Bit Mapped Options		–	*	118 (76h)	Definition: S23 Indicates the status of command options. Bits 0–1 Speaker Volume Ln 0 = L0 1 = L1 2 = L2 (Default) 3 = L3 Bits 2–3 Speaker Control Mn 0 = M0 1 = M1 (Default) 2 = M2 3 = M3 Bits 4–6 Limit Result Codes Xn 0 = X0 4 = X1 5 = X2 6 = X3 7 = X4 (Default) Bit 7 Reserved
S23	General Bit Mapped Options Status		–	*	0	Definition: S23 Indicates the status of command options. Bits 0–5 Not Used Bits 6–7 Guard Tone(&Gn) 0 = None(&G0) (Default) 1 = None(&G1) 2 = 1800 Hz (&G2)
S25	Delay To DTR	0–255	10 ms	*	5	Definition: S25 Sets the length of time that the modem will ignore DTR for taking the action speci- fied by &Dn. The delay is specified in hundredts of seconds.
S27	Bit Mapped Options Status		–	*	73	Definition: S27 Indicates the status of command options. Bits 0–5 Reserved BBit 6 CCITT/Bell Select(Bn) 0 = CCITT 1 = Bell Bit 7 Reserved

Register	Function	Range	Units	Saved	Default	Note
S30	Disconnect Inactivity Timer	0–255	10 s	*	0	This register has to be redefined. 10 s.
S31	Results Bit Mapped Options			*	192	<p>Definition: S31</p> <p>Indicates the status of command options.</p> <p>Bit 0 Single Line Connect Message \Vn 0 = \V0 1 = \V1</p> <p>Bits 1 Reserved</p> <p>Bits 2–3 Error Connect Message messages 0 = W0 (Default) 1 = W1 2 = W2</p> <p>Bits 4–5 Not Used</p> <p>Bit 6-7 Reserved</p>
S36	LAPM Failure Control	–	–	*	7	<p>Definition: S36</p> <p>Bits 0–2 indicates what should happen upon a LAPM failure. These fallback options are initiated immediately upon connection if S48 = 128.0.</p> <p>Bits 0–2</p> <p>0 = Modem disconnects. 1 = Modems Stays on-line and a direct mode connection will be established. 2 = Reserved. 3 = Modem stays on-line and Normal Mode connection will be established. 4 = An MNP connection is attempted and if it fails, the modem disconnects. 5 = An MNP connection is attempted and if it fails, a direct mode connection is established. 6 = Reserved. 7 = An MNP connection is attempted and if it fails, normal mode connection is established.</p> <p>Bits 3–7 Reserved.</p>

Register	Function	Range	Units	Saved	Default	Note
S38	Delay Before Hang-Up		–	*	20	<p>Definition: S38</p> <p>Specifies the delay between the modem receives the H command (hang-up) to disconnect and the disconnect action. Applicable to error-correction connection only. Used to ensure that the modem buffer is sent before the the modem disconnects.</p> <p>For S38 values 0–254 the modem waits this time until all data is sent from buffer before disconnecting.</p> <p>S38 = 255 the modem does not time out.</p>
S39	Flow Control Bit Mapped Options Status		–	*	3	<p>Definition: S39</p> <p>Bits 0–2 status of command options.</p> <p>0 = &K0 No flow control.</p> <p>3 = &K3 RTS/CTS</p> <p>4 = &K4 XON/XOFF</p> <p>5 = Reserved XON/XOFF</p> <p>Bits 3–7 Reserved</p>
S40	General Bit-Mapped Options Status	–	–	*	168	<p>Definition: S40</p> <p>Indicates the status of command options.</p> <p>Bit 0–2 Reserved</p> <p>Bits 3–5 Break handling (\Kn)</p> <p>0 = \K0</p> <p>1 = \K1</p> <p>2 = \K2</p> <p>3 = \K3</p> <p>4 = \K4</p> <p>5 = \K5 (Default)</p> <p>Bits 6–7 Reserved</p>

Register	Function	Range	Units	Saved	Default	Note												
S41	General Bit-Mapped Options Status	–	–	*	195 (C3h)	<p>Definition: S41 Indicates the status of command options. Bits 0-1 Compression Selection %Cn. 0 = %C0 Disabled 1 = %C1 MNP-5 2 = %C2 V.42bis 3 = %C3 MNP 5 and V.42bis</p> <p>Bits 2, 6 Auto Retrain, Fallback/Fall forward.</p> <table border="0"> <tr> <td>Bit 6</td> <td>Bit 2</td> <td></td> </tr> <tr> <td>0</td> <td>0</td> <td>Disabled %E0</td> </tr> <tr> <td>0</td> <td>1</td> <td>Retrain Enabled %E1</td> </tr> <tr> <td>1</td> <td>0</td> <td>Fallback/fall forward enabled %E2</td> </tr> </table> <p>Bit 3–5 Reserved Bit 7 Reserved</p>	Bit 6	Bit 2		0	0	Disabled %E0	0	1	Retrain Enabled %E1	1	0	Fallback/fall forward enabled %E2
Bit 6	Bit 2																	
0	0	Disabled %E0																
0	1	Retrain Enabled %E1																
1	0	Fallback/fall forward enabled %E2																
S46	Data Compression Control	–	–	*	138	<p>Definition: S46 Selects compression.</p> <p>S46=136 Error correction protocol with no compression.</p> <p>S46=138 Execute error correction with compression.</p>												

Register	Function	Range	Units	Saved	Default	Note
S48	V.42 Negotiation Control	–	–	*	7	<p>Definition: S48</p> <p>The V.42 negotiation process determines the capabilities of the remote modem. However, when the capabilities of the remote modem are known and negotiation is unnecessary, this process can be bypassed if so desired.</p> <p>S48=0 Disable Negotiation and proceed with LAPM.</p> <p>S48=7 Enable negotiation.</p> <p>S48=128 Disable negotiation and proceed with the fallback action specified in S36.</p>
S91	PSTN Transmit Level	0–15	dBm	*		<p>Definition: S91</p> <p>Sets the transmit level. Note that in PSTN mode the country specific parameters limits the maximum value.</p>

Register	Function	Range	Units	Saved	Default	Note									
S95	Extended Result Codes		–	*	0	<p>Definition: S95 Settings will enable result code regardless of ATW setting.</p> <p>Bit 0 CONNECT indicates DCD speed</p> <p>Bit 1 Append to CONNECT XXXX result code in error-correction mode</p> <p>Bit 2 Enable +MCR: XXXX result code (XXXX=rate)</p> <p>Bit 3 Enable +ER:XXXX result code (XXXX = protocol identifier)</p> <p>Bit 4 Reserved</p> <p>Bit 5 Enable +DR: result code (XXXX = compression type).</p> <p>Bit 6–7 Reserved</p>									
S136	PSTN line impedance adaptation					<p>Definition: S136 Bits 2,3 selects line impedance adaptation</p> <table border="0"> <tr> <td>Bit 3</td> <td>Bit 2</td> <td></td> </tr> <tr> <td>0</td> <td>1</td> <td>Real</td> </tr> <tr> <td>1</td> <td>1</td> <td>Complex</td> </tr> </table>	Bit 3	Bit 2		0	1	Real	1	1	Complex
Bit 3	Bit 2														
0	1	Real													
1	1	Complex													

Register	Function	Range	Units	Saved	Default	Note
S200	Multidrop delay before data when carrier activated	0–255	ms	*	23	
S201	Multidrop delay after data when carrier activated	0–255	ms	*	10	
S202	UART TX buffer threshold (lo byte)	0–255	-	*	255	
S203	UART TX buffer threshold (hi byte)	0–255	-	*	0	
S204	UART TX buffer character timeout	0-255	ms	*	4	0 = No timeout, 255 = Wait forever; other values timeout in Ms
S205	UART RX buffer threshold (lo byte)	0-255	-	*	255	
S206	UART RX buffer threshold (hi byte)	0-255	-	*	0	
S207	UART RX buffer character timeout	0-255	ms	*	4	0 = No timeout, 255 = Wait forever; other values timeout in Ms
S208	UART buffers enabled/disabled	0-1	-	*	0	0 = Disabled, 1 = Enabled
S209	DTMF format	0-1	-	*		0=Format, 1=No formatted

Register	Function	Range	Units	Saved	Default	Note
S210	General function bitmap	0-255	-	*	4	Bit 0: Break control 0 = Inactive, 1 = Active Bit 1: Protocol 0 = Inactive, 1 = Active Bit 2: Remote config 0 = Inactive, 1 = Active Bit 3: Ignore error 0 = Inactive, 1 = Active Bit 4: DTR hot-call 0 = Inactive, 1 = Active Bit 5: TX hot-call 0 = Inactive, 1 = Active Bit 6: Reserved Bit 7: Reserved
S211	On-hook timer delay	0-255	ms	*	0	0 = No delay
S212	Off-hook timer delay	0-255	ms	*	0	0 = No delay
S213	DCE data out timer delay	0-255	ms	*	0	0 = No delay
S250	Line status enabled parameter	0-255	-	*	1	0 = Disabled, 1 = Enabled, other values reserved
S251	Line status interval parameter	0-255	10 ms	*	10	
S252	Line status parameter SNR threshold	0-255	-	*	15	
S253	Line status parameter RX level threshold	0-255	-	*	2	
S254	Line status	-	-	-	0	0 = OK 4 = Error 252 = SNR disconnect 253 = RX level disconnect Other values reserved

Result codes Codes and values:

Short Form	Long Form	Description
0	OK	A command line has been executed.
1	CONNECT	For X command values specifying no speed reporting, the modem has connected to the line and either the line speed is 300 bit/s and line speed is enabled (W2), or the DTE speed is 300 bit/s and DTE reporting is enabled (W0).
2	RING	Indicates an incoming call (if valid RING)
3	NO CARRIER	Sent when attempting a call if: <ol style="list-style-type: none"> 1. Ringback is detected and later ceases but no carrier is detected within the period of time predetermined by register S7, or 2. No ringback is detected within the period of time determined by register S7. Also sent when the modem auto-disconnects due to loss of carrier. For X0, sent for the following conditions: <ol style="list-style-type: none"> 1. If busy tone detection is enforced, busy or circuit busy has been detected. 2. If dial tone detection is enforced or selected, dial tone has not been detected.
4	ERROR	Sent during an attempt to execute a command line if any of the following conditions occur: <ol style="list-style-type: none"> 1. The command line contains a syntax error. 2. The modem can not execute a command contained in the command line, i.e., the command does not exist or is not supported. 3. A command parameter within the command line is outside the permitted range. For X0, X1, X2, and X3 this message is sent instead of DELAYED and BLACKLISTED.
5	CONNECT 1 200	The modem has connected to the line and either the line speed is 1200 bit/s and DCE speed reporting is enabled, or the DTE speed is 1200 bits/s and DTE speed reporting is enabled.
6	NO DIALTONE	For X2 and X4, the modem has been instructed to wait for dial tone during dialing but none is received.
7	BUSY	For X3 and X4, if busy tone detection is enforced, the busy(engaged) signal is detected on the line when the modem is attempting to originate a call.
8	NO ANSWER	The modem is attempting to originate a call if a continuous ringback signal is detected on the line until the expiration of the timer S7.
9	CONNECT 600	Connection, DTE speed 600 bit/s, DTE speed enabled
10	CONNECT 2 400	The modem has connected to the line and either line speed 2 400 bit/s., DCE speed reporting is enabled, or the DTE speed 4 800 bit/s, and DTE speed reporting is enabled.

Short Form	Long Form	Description
11	CONNECT 4 800	The modem has connected to the line and either line speed 4 800 bit/s., DCE speed reporting is enabled, or the DTE speed 4 800 bit/s, and DTE speed reporting is enabled.
12	CONNECT 9 600	The modem has connected to the line and either line speed 9 600 bit/s., DCE speed reporting is enabled, or the DTE speed 9 600 bit/s, and DTE speed reporting is enabled.
13	CONNECT 7 200	The modem has connected to the line at 7 200 bit/s and DCE speed reporting is enabled.
14	CONNECT 12 000	The modem has connected to the line at 12 000 bit/s and DCE speed reporting is enabled.
15	CONNECT 14 400	The modem has connected to the line at 14 400 bit/s and DCE speed reporting is enabled.
16	CONNECT 19 200	The modem has connected to the line and either line speed 19 200 bit/s., DCE speed reporting is enabled, or the DTE speed 19 200 bit/s, and DTE speed reporting is enabled.
17	CONNECT 38 400	Connection, DTE speed 38 400 bit/s, DTE speed enabled
18	CONNECT 57 600	Connection, DTE speed 57 600 bit/s, DTE speed enabled
19	CONNECT 115 200	Connection, DTE speed 115 200 bit/s, DTE speed enabled
22	CONNECT 75TX/1200RX	The modem has established a V.23 originate connection and line speed reporting is enabled.
23	CONNECT 1200TX/75RX	The modem has established a V.23 answer connection and line speed reporting is enabled.
24	DELAYED	For X4, sent when a call fails to connect and the number is considered "delayed" due to country blacklisting requirements.
32	BLACKLISTED	For X4, sent when a call fails to connect and the number is considered "blacklisted" due to country blacklisting requirements.
33	FAX	A fax modem connection is established in a facsimile mode.
35	DATA	A data modem connection is established in a facsimile mode.
40	+MRR: 300	The modem has connected to the line at 300 bit/s and carrier reporting is enabled (see S95 and Xn).
44	+MRR: 1200/75	The V.23 backward channel is detected and carrier reporting is enabled (see S95 and Xn).
45	+MRR: 75/1200	The V.23 forward channel is detected and carrier reporting is enabled (see S95 and Xn).
46	+MRR: 1200	The modem has connected to the line at 1200bit/s and carrier reporting is enabled (see S95 and Xn).

Short Form	Long Form	Description
47	+MRR: 2400	The modem has connected to the line at 2400 bit/s and carrier reporting is enabled (see S95 and Xn).
48	+MRR: 4800	The modem has connected to the line at 4800 bit/s and carrier reporting is enabled (see S95 and Xn).
49	+MRR: 7200	The modem has connected to the line at 7200 bit/s and carrier reporting is enabled (see S95 and Xn).
50	+MRR: 9600	The modem has connected to the line at 9600 bit/s and carrier reporting is enabled (see S95 and Xn).
51	+MRR: 12000	The modem has connected to the line at 12000 bit/s and carrier reporting is enabled (see S95 and Xn).
52	+MRR: 14400	The modem has connected to the line at 14400 bit/s and carrier reporting is enabled (see S95 and Xn).
53	+MRR: 16800	The modem has connected to the line at 16800 bit/s and carrier reporting is enabled (see S95 and Xn).
54	+MRR: 19200	The modem has connected to the line at 19200 bit/s and carrier reporting is enabled (see S95 and Xn).
55	+MRR: 21600	The modem has connected to the line at 21600 bit/s and carrier reporting is enabled (see S95 and Xn).
56	+MRR: 24000	The modem has connected to the line at 24000 bit/s and carrier reporting is enabled (see S95 and Xn).
57	+MRR: 26400	The modem has connected to the line at 26400 bit/s and carrier reporting is enabled (see S95 and Xn).
58	+MRR: 28800	The modem has connected to the line at 28800 bit/s and carrier reporting is enabled (see S95 and Xn).
59	CONNECT 16 800	Connection, line speed 16 800 bit/s and DTE speed reporting is enabled
61	CONNECT 21 600	Connection, line speed 21 600 bit/s and DTE speed reporting is enabled
62	CONNECT 24 000	Connection, line speed 24 000 bit/s and DTE speed reporting is enabled
63	CONNECT 26 400	Connection, line speed 26 400 bit/s and DTE speed reporting is enabled
64	CONNECT 28 800	Connection, line speed 28 800 bit/s and DTE speed reporting is enabled
66	+DR:ALT	The modem has connected to the line in MNP Class 5 and +DR: message reporting has been enabled (see S95, Wn, and Xn)
67	+DR:V.42B	The modem has connected to the line in V.42b and +DR: message reporting has been enabled (see S95, Wn, and Xn)
69	+DR:NONE	The modem has connected to the line without compression and +DR: message reporting has been enabled (see S95, Wn, and Xn)

Short Form	Long Form	Description
70	+ER:NONE	The modem has connected to the line without any error correction mode and +ER: message reporting has been enabled.
77	+ER:LAPM	The modem has connected to the line in V.42 LAPM error correction mode and +ER: message reporting has been enabled.
78	+MRR: 31 200	The modem has connected to the line at 31 200 bit/s and carrier reporting is enabled.
79	+MRR: 33 600	The modem has connected to the line at 33 600 bit/s and carrier reporting is enabled.
80	+ER:ALT	Sent when modem has connected in the MNP mode of error correction, and +ER: message has been enabled (see S95, Wn, and Xn).
83	LINE IN USE	The modem attempted to go off-hook when an extension was already occupying the line.
84	CONNECT 33 600	Connection, DTE speed 33 600 bit/s, DTE speed reporting is enabled
91	CONNECT 31 200	Connection, DTE speed 31 200 bit/s, DTE speed reporting is enabled
134	+MCR:B103	The modem has connected to the line with Bell 103 modulation and modulation reporting is enabled (see +MR, Wn, and Xn).
135	+MCR:B212	The modem has connected to the line with Bell 212 modulation and modulation reporting is enabled (see +MR, Wn, and Xn).
136	+MCR:V21	The modem has connected to the line with V21 modulation and modulation reporting is enabled (see +MR, Wn, and Xn).
137	+MCR:V22	The modem has connected to the line with V22 modulation and modulation reporting is enabled (see +MR, Wn, and Xn).
138	+MCR:V22B	The modem has connected to the line with V22B modulation and modulation reporting is enabled (see +MR, Wn, and Xn).
139	+MCR:V23	The modem has connected to the line with V23 modulation and modulation reporting is enabled (see +MR, Wn, and Xn).
140	+MCR:V32	The modem has connected to the line with V32 modulation and modulation reporting is enabled (see +MR, Wn, and Xn).
141	+MCR:V32B	The modem has connected to the line with V32B modulation and modulation reporting is enabled (see +MR, Wn, and Xn).
142	+MCR:V34	The modem has connected to the line with V34 modulation and modulation reporting is enabled (see +MR, Wn, and Xn).
145	+MCR:V90	The modem has connected to the line with V90 modulation and modulation reporting is enabled (see +MR, Wn, and Xn).
180	CONNECT 28000	The modem has connected to the line at 28000 bit/s and DCE reporting is enabled.

Short Form	Long Form	Description
181	CONNECT 29333	The modem has connected to the line at 29333 bit/s and DCE reporting is enabled.
182	CONNECT 30667	The modem has connected to the line at 30667 bit/s and DCE reporting is enabled.
183	CONNECT 33333	The modem has connected to the line at 33333 bit/s and DCE reporting is enabled.
184	CONNECT 34667	The modem has connected to the line at 34667 bit/s and DCE reporting is enabled.
185	CONNECT 37333	The modem has connected to the line at 37333 bit/s and DCE reporting is enabled.
186	CONNECT 38667	The modem has connected to the line at 38667 bit/s and DCE reporting is enabled.
187	CONNECT 41333	The modem has connected to the line at 41333 bit/s and DCE reporting is enabled.
188	CONNECT 42667	The modem has connected to the line at 42667 bit/s and DCE reporting is enabled.
189	CONNECT 41333	The modem has connected to the line at 41333 bit/s and DCE reporting is enabled.
190	CONNECT 46667	The modem has connected to the line at 46667 bit/s and DCE reporting is enabled.
191	CONNECT 49333	The modem has connected to the line at 49333 bit/s and DCE reporting is enabled.
192	CONNECT 50667	The modem has connected to the line at 50667 bit/s and DCE reporting is enabled.
193	CONNECT 53333	The modem has connected to the line at 53333 bit/s and DCE reporting is enabled.
194	CONNECT 54667	The modem has connected to the line at 54667 bit/s and DCE reporting is enabled.
195	+MRR:28000	The modem has connected to the line at 28000 bit/s and carrier reporting is enabled.
196	+MRR:29333	The modem has connected to the line at 29333 bit/s and carrier reporting is enabled.
197	+MRR:30667	The modem has connected to the line at 30677 bit/s and carrier reporting is enabled.
198	+MRR:33333	The modem has connected to the line at 33333 bit/s and carrier reporting is enabled.
199	+MRR:34667	The modem has connected to the line at 34667 bit/s and carrier reporting is enabled.
200	+MRR:37333	The modem has connected to the line at 37333 bit/s and carrier reporting is enabled.

Short Form	Long Form	Description
201	+MRR:38667	The modem has connected to the line at 38667 bit/s and carrier reporting is enabled.
202	+MRR:41333	The modem has connected to the line at 41333 bit/s and carrier reporting is enabled.
203	+MRR:42667	The modem has connected to the line at 42667 bit/s and carrier reporting is enabled.
204	+MRR:45333	The modem has connected to the line at 45333 bit/s and carrier reporting is enabled.
205	+MRR:46667	The modem has connected to the line at 46667 bit/s and carrier reporting is enabled.
206	+MRR:49333	The modem has connected to the line at 49333 bit/s and carrier reporting is enabled.
207	+MRR:50667	The modem has connected to the line at 50667 bit/s and carrier reporting is enabled.
208	+MRR:53333	The modem has connected to the line at 53333 bit/s and carrier reporting is enabled.
209	+MRR:54667	The modem has connected to the line at 54667 bit/s and carrier reporting is enabled.

Country codes:

Country name	
[ITU_T E.180 supplement 2]	+GCI code [T.35]
Australia	09
Austria	0A
Belgium	0F
Brazil	16
Czechoslovakia (Slovakia and Czech Rep.)	2E
Denmark	31
Finland	3C
France [Note:B]	3D
Germany	04
Greece	46
Hungary	51
Indonesia	54
Ireland	57
Italy	59
Japan	00
Luxembourg	69
Malaysia	6C
Norway	82
Philippines	89
Poland	8A
Portugal	8B
Singapore	9C
South Africa	9F
South Korea	61
Spain	A0
Sweden	A5
Switzerland	A6
Taiwan [Note:A]	C5
Thailand	A9
The Netherlands	7B
Turkey	AE
United Kingdom [Note:C]	B4
Universal	C7
USA	B5
USSR [Note: D]	B8

Country code table 1.

Country name	
[ITU_T E.180 supplement 2]	+GCI code [T.35]
Argentina	07
Canada	20
Cayman Islands	22
Chile	25
Costa rica	2B
Cuba	2C
Ecuador	35
El salvador	37
Honduras	4F
Hongkong	50
Jamaica	5B
Mexico	73
New zealand	7E
Pakistan	84
Panama	85
Paraguay	87
Sri lanka	A1
Suriname	A3
Uruguay	B7

Country code table 2.

All countries in Country code table 2, internally refer to the universal country and can be activated using the specific country code or by using code C7.

REMARKS:

Note A: There is no country code for Taiwan in ITU-T Recommendation T.35

Note B: Following countries follow the French settings

- French Polynesia
- Guadeloupe (french dep.)
- Guiana (french dep.)
- Martinique (french dep.)
- Mayotte
- New Caledonia
- Reunion (french dep.)
- S. Pierre and Miquelon
- Wallis and Futuna

Note C: Following countries follow the UK settings

- Falkland Islands
- Channel Islands: Jersey

Note D: Countries previously part of the USSR normally follow the USSR settings

- Armenia (ARM)
- Azerbaijan (AZE)
- Belarus (BLR)
- Estonia (EST)
- Georgia (GEO)
- Kazakhstan (KAZ)
- Kyrgyzstan (KGZ)
- Latvia (LVA)
- Lithuania (LTU)
- Moldova (MDA)
- Russian Federation (RUS)
- Tajikistan (TJK)
- Turkmenistan (TKM)
- Ukraine (UKR)

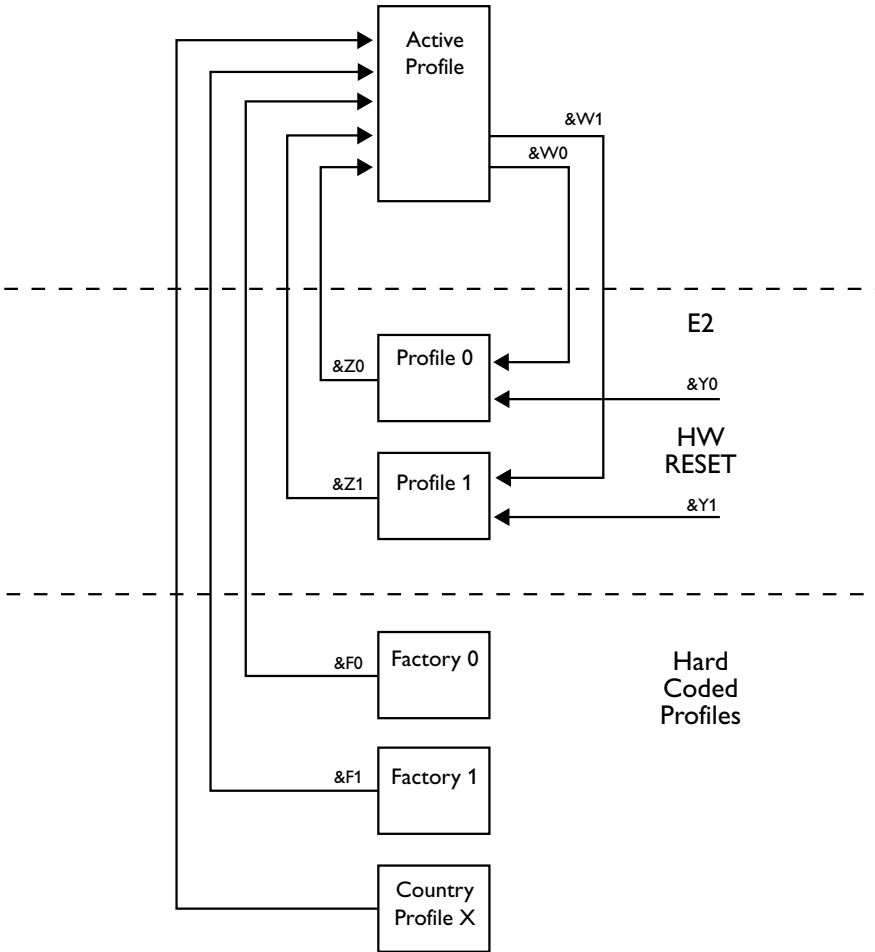

Priority:

Country Profile has precedence of all other profiles

Factory Profile has precedence of profile 0 and profile 1, however, this is not always the case.

Parameters affected by default settings

Command	Automatically saved in EEPROM&F2 sets default	Incl. Factory Setting, &F sets default and &W saves	Incl. Country Profile	Default setting
A				-
&An		*		&A0
Bn		*		B0
\Bn				-
&Bn		*		&B0
Cn				-
%Cn		*		%C3
&Cn		*		&C1
D				-
&Dn		*		&D0
En		*		E1
%En		*		%E2
F		*		F0
%F		*		%F3
&Fn		*		-
&Gn		*		&G0
*Gn	*			*G0
+GCI			*	+GCI=C7
Hn				-
In				-
+ICF		*		+ICF=0
+IPR		*		+IPR=0
\Kn		*		\K5
&Kn		*		&K0
Ln		*		L3
%L				-
*L				-
Mn		*		M1
+MS		*		+MS=AUTOV8
\Nn		*		\N3
On				-

Command	Automatically saved in EEPROM&F2 sets default	Incl. Factory Setting, &F sets default and &W saves	Incl. Country Profile	Default setting
*Pn	*			no password
Qn		*		Q0
%Q				-
&Qn		*		&Q5
&R				-
S		*		See respective register
&Sn		*		&S0
Vn				V1
\Vn		*		\V0
&Vn				-
Wn		*		W0
&Wn		*		-
*WACCTAB	*			Table cleared
*WCB	*			*WCB=0
*WCID	*			*WCID=0,0
*WCBTAB	*			Table cleared
*WCBTIME	*			*WCBTIME=5
*WDB	*			*WDB="'",3,0
*WIE	*			*WIE=0
*WIOL	*			Table cleared
*WIOD	*			-
*WIOP	*			*WIOP=0,0,0,0,0
*WIOT				-
*WRCP	*			*WRCP="'"
*WRCA	*			*WRCA=1
*WRCE	*			-
Xn		*		X4
&Yn	*			&Y0
Zn				-
&Zn	*			



Westermo Teleindustri AB • SE-640 40 Stora Sundby, Sweden
Phone +46 16 42 80 00 Fax +46 16 42 80 01
E-mail: info@westermo.se
Westermo Web site: www.westermo.com

Subsidiaries

Westermo Data Communications AB
SE-724 81 Västerås
Phone: +46 (0)16 42 80 00 • Fax: +46 (0)21 35 18 50
E-mail: info.sverige@westermo.se

Westermo OnTime AS
Gladsvei 20 0489 Oslo, Norway
Phone +47 22 09 03 03 • Fax +47 22 09 03 10
E-mail: contact@ontimenet.com

Westermo Data Communications Ltd
Talisman Business Centre • Duncan Road
Park Gate, Southampton • SO31 7GA
Phone: +44(0)1489 580-585 • Fax: +44(0)1489 580586
E-Mail: sales@westermo.co.uk

Westermo Data Communications GmbH
Goethestraße 67, 68753 Waghäusel
Tel.: +49(0)7254-95400-0 • Fax.: +49(0)7254-95400-9
E-Mail: info@westermo.de

Westermo Data Communications S.A.R.L.
9 Chemin de Chilly 91160 CHAMPLAN
Tél : +33 1 69 10 21 00 • Fax : +33 1 69 10 21 01
E-mail : infos@westermo.fr

Westermo Data Communications Pte Ltd
2 Soon W'ing Road #08-05
Soon W'ing Industrial Building
Singapore 347893
Phone +65 6743 9801 • Fax +65 6745 0670
E-mail: earnestphua@westermo.com.sg

Westermo Teleindustri AB have distributors in several countries, contact us for further information.